

Code: AE02

Subject: ENGINEERING GRAPHICS

AMIETE – ET (OLD SCHEME)

Time: 4 Hours

DECEMBER 2011

Max. Marks: 100

NOTE:

1. Please write your Roll No. at the space provided on each page immediately after receiving the Question Paper.
2. (a) There are SEVEN questions in all and these are arranged in three Sections A, B and C.
(b) Sections A and B are compulsory and carry 20 marks and 32 marks respectively.
(c) Out of remaining 5 questions (of 16 marks each) in Section C students are required to answer any 3 questions.
3. Detach this sheet from the question paper and write answers on this sheet only on Pages 1 & 2. Attach it to the main drawing sheet. Remaining questions are to be answered on the main drawing sheet.
4. All dimensions given are in mm. Use suitable values of any missing and mismatching dimensions.
5. Use BIS Code: SP: 46-1988 for all drawings and do not rub off construction lines.

SECTION A (Compulsory) – Marks – 20

Note : - Answer this on question paper itself and annex with the drawing sheet.

Q1. Choose the correct or best alternative in the following:

(2 x 10 = 20)

QUESTIONS**ANSWER HERE**

a. The double ordinate through the focus of a conic is called the

- | | |
|------------------|--------------|
| (A) foci | (B) ordinate |
| (C) latus rectum | (D) axis |

b. When a hexagonal lamina is inclined to horizontal plane and perpendicular to vertical plane, its front view is a

- | | |
|-----------------------|---------------------|
| (A) line | (B) regular hexagon |
| (C) irregular hexagon | (D) none |

CENTRE STAMP

Signature of Suptd/invigilator

Code: AE02

Subject: ENGINEERING GRAPHICS

- c. Application of involute curve is in
(A) threaded parts (B) cams
(C) couplings (D) gears _____
- d. If the slant height of the cone is equal to the diameter of the base circle, the shape of the development of the cone is
(A) circle (B) semicircle
(C) right angled sector (D) triangle _____
- e. HEXAHEDRON is a
(A) cube (B) rectangular prism
(C) hexagonal prism (D) hexagonal pyramid _____
- f. In isometric projection the size of the drawing is _____ the actual dimensions
(A) smaller than (B) larger than
(C) equal to (D) half of _____
- g. When the measurements are made in two units _____ scales are used
(A) diagonal (B) plain
(C) vernier (D) comparative _____
- h. _____ is a cylindrical rod threaded at both the ends and left plain in the middle.
(A) bolt (B) nut
(C) stud (D) washer _____
- i. Plan and elevation of an object lie below X-Y line in an orthographic projection. Then the object is in _____
(A) I quadrant (B) II quadrant
(C) III quadrant (D) IV quadrant _____
- j. The eccentricity of a hyperbola is
(A) greater than 1 (B) less than 1
(C) equal to 1 (D) none of these _____

SECTION B (Compulsory)

Code: AE02

Subject: ENGINEERING GRAPHICS

- Q.2 Draw front view and top view of the object shown in Fig.1, when views given in Fig.1 are taken from the direction 'A' to get its front view. Show all dimensions. (16+10)

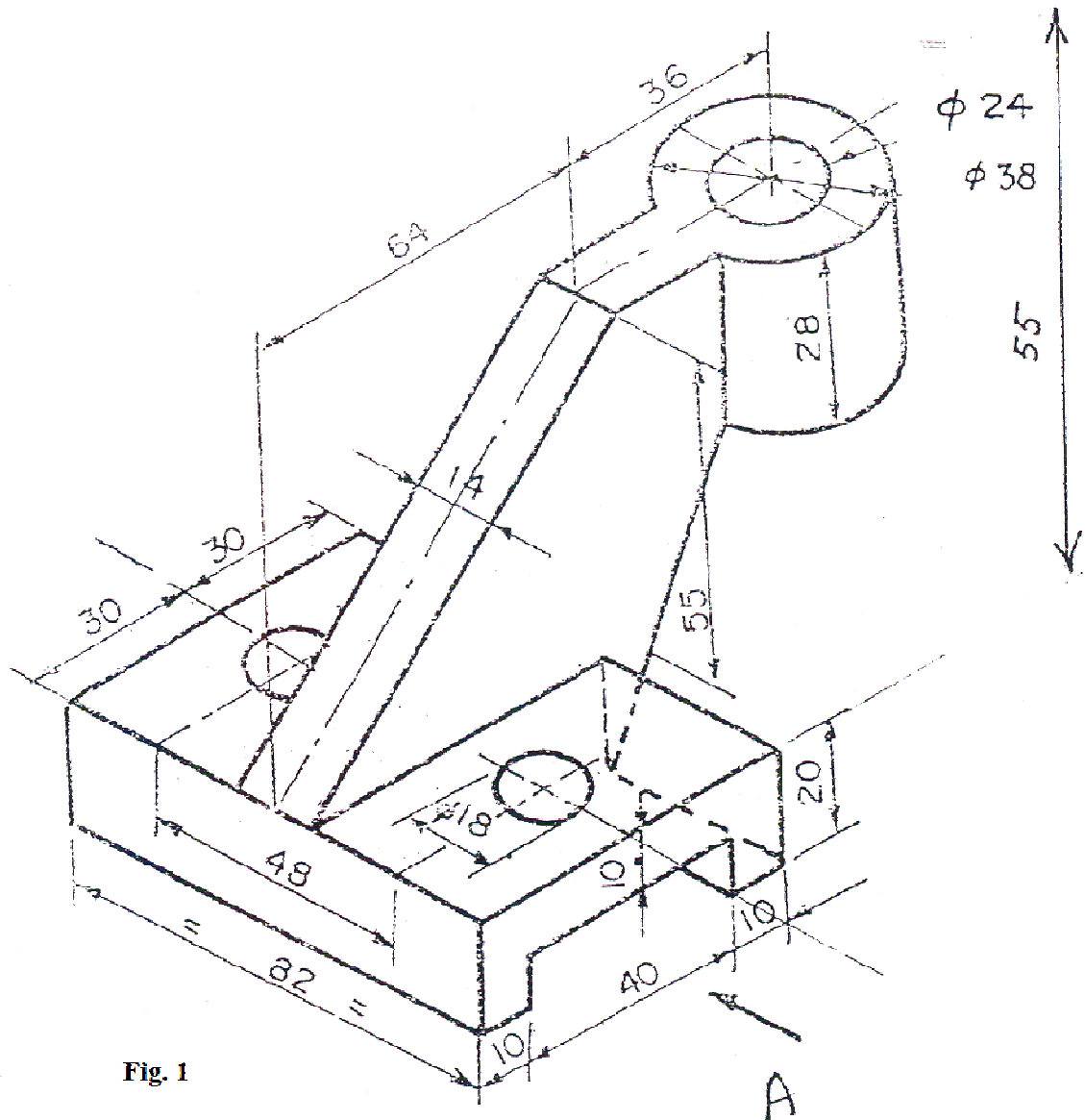

Fig. 1

SECTION C

Answer any THREE Questions. Each question carries 16 marks.

- Q.3 a. Construct a scale of R.F. = $\frac{1}{60}$ to read meter, decimeter and centimeter. Mark a distance of 8 meter, 5 decimeter and 4 centimeter on it. (8)

Code: AE02**Subject: ENGINEERING GRAPHICS**

- b. Front view of a line measures 75 mm and the line is inclined at 30° to the V.P. End A of the line is 30 mm above H.P. and 20 mm in front of V.P. If its top view length is 55 mm, then draw projections and find the inclination with the H.P. (8)
- Q.4** a. A regular hexagonal plate of 30 mm side is resting with one of its corner in the H.P. and plate makes an angle of 45° with the H.P. Draw projection of the plate. (8)
- b. Draw single riveted lap joint in two views using thickness of plate 5 mm. Show all standard dimensions. (8)
- Q.5** A cone of 40 mm diameter and 60 mm height is lying in the H.P. on one of its generator. If a horizontal cutting plane bisects the axis then draw sectional top view. (16)
- Q.6** A tetrahedron of 50 mm side is resting with its base on H.P. and bisected by a cutting plane inclined at 30° to the H.P. Draw isometric view of the remaining portion of the solid. (16)
- Q.7** Draw with free hand sketch any **TWO** of the following showing complete details:
- (i) Flange coupling.
 - (ii) V-belt pulley
 - (iii) A hexagonal headed bolt with hexagonal nut.
 - (iv) Three type of fits.
 - (v) Cotter joint.
 - (vi) Any two locking devices with nut. (8+8)