

Note: **FIITJEE** solutions to IIT-JEE, 2005 Screening Test is based on Screening Test paper created using memory retention of select **FIITJEE** students appeared in this test and hence may not exactly be the same as the original paper. However, every effort has been made to reproduce the original paper in the interest of the aspiring students.

# FIITJEE solutions to IIT-JEE, 2005 Screening

## PHYSICS

57. Find current in  $2\Omega$  resistor

- (A) 0  
(B) 2 A  
(C) 4 A  
(D) 1 A

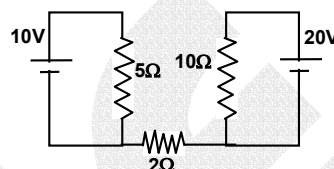

Ans. A

Sol. According to Kirchoff's junction rule no current passes through  $2\Omega$  resistor.

$$\therefore i = 0$$

58. In Young's double slit experiment the angular position of a point on the central maxima whose intensity is one fourth of maximum intensity

- (A)  $\sin^{-1}(\lambda/d)$   
(B)  $\sin^{-1}(\lambda/2d)$   
(C)  $\sin^{-1}(\lambda/3d)$   
(D)  $\sin^{-1}(\lambda/4d)$

Ans. C

Sol.  $I = I_{\max} \cos^2 \phi / 2$

$$\Rightarrow \phi = 2\pi/3 \text{ and } \frac{2\pi}{\lambda} d \sin \theta = \frac{2\pi}{3}$$

$$\therefore \theta = \sin^{-1}\left(\frac{\lambda}{3d}\right)$$

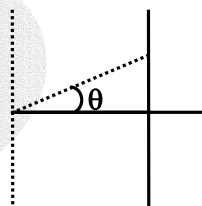

59. Ratio of area of hole to beaker is 0.1. Height of liquid in beaker is 3m, and hole is at the height of 52.5 cm from the bottom of beaker, find the square of the velocity of liquid coming out from the hole

- (A)  $50 \text{ (m/s)}^2$   
(B)  $50.5 \text{ (m/s)}^2$   
(C)  $51 \text{ (m/s)}^2$   
(D)  $42 \text{ (m/s)}^2$

Ans. A

Sol.  $u^2 = \frac{2gh}{\left[1 - \left(\frac{A_0}{A}\right)^2\right]} = 50 \text{ (m/s)}^2$

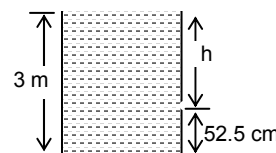

60. In the figure shown, a cubical block is held stationary against a rough wall by applying force 'F' then **incorrect** statement among the following is

- (A) frictional force,  $f = Mg$   
(B)  $F = N$ ,  $N$  is normal reaction  
(C)  $F$  does not apply any torque  
(D)  $N$  does not apply any torque

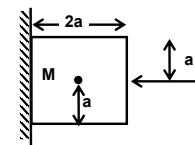

Ans. D

Sol. For equilibrium,  $f = Mg$   
 $F = N$

For rotational equilibrium normal will shift downward.

Hence torque due to friction about centre of mass = Torque due to Normal reaction about centre of mass.

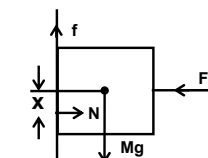

IIT-JEE-2005-S-2

61. Three infinitely charged sheets are kept parallel to  $x - y$  plane having charge densities as shown. Then the value of electric field at 'P' is

- (A)  $\frac{-4\sigma}{\epsilon_0} \hat{k}$  (B)  $\frac{4\sigma}{\epsilon_0} \hat{k}$   
 (C)  $\frac{-2\sigma}{\epsilon_0} \hat{k}$  (D)  $\frac{2\sigma}{\epsilon_0} \hat{k}$

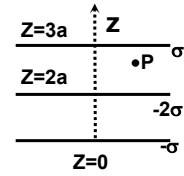

Ans. C

Sol. 
$$\vec{E}_P = \frac{\sigma}{2\epsilon_0}(-\hat{k}) + \frac{(-2\sigma)}{2\epsilon_0}(\hat{k}) + \frac{(-\sigma)}{2\epsilon_0}(\hat{k})$$

$$= \frac{-2\sigma}{\epsilon_0} \hat{k}$$

62. A cylindrical conducting rod is kept with its axis along positive  $z$ -axis, where a uniform magnetic field exists parallel to  $z$ -axis. The current induced in the cylinder is

- (A) zero (B) clockwise as seen from  $+z$  axis  
 (C) anti-clockwise as seen from  $+z$  axis (D) opposite to the direction of magnetic field.

Ans. A

Sol. Since  $B$  is constant

$$\therefore \frac{d\phi}{dt} = 0$$

$$\therefore i = 0$$

63. A circular disc of radius  $R/3$  is cut from a circular disc of radius  $R$  and mass  $9M$  as shown. Then moment of inertia of remaining disc about 'O' perpendicular to the plane of the disc is

- (A)  $4MR^2$  (B)  $9MR^2$   
 (C)  $\frac{37}{9}MR^2$  (D)  $\frac{40}{9}MR^2$

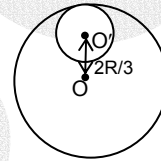

Ans. A

Sol. 
$$I_0 = \frac{9MR^2}{2} - \left[ \frac{M(R/3)^2}{2} + M\left(\frac{2R}{3}\right)^2 \right] = 4MR^2$$

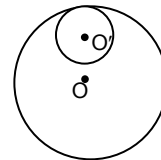

64. Depict the shown  $v - x$  graph in a-  $x$  graph.

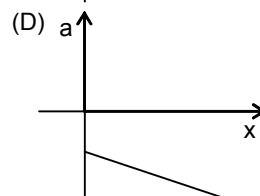
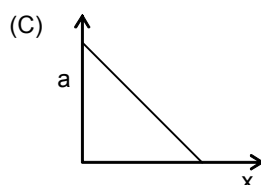
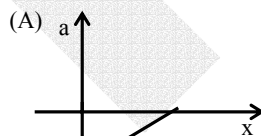
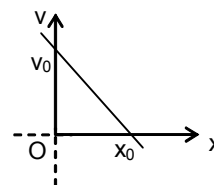

**Ans. A**

Sol. Equation of curve is

$$\frac{v}{v_0} + \frac{x}{x_0} = 1$$

$$\therefore v = \left(1 - \frac{x}{x_0}\right)v_0$$

$$\therefore a = \frac{dv}{dt} = -\frac{v_0}{x_0}(v) = -\frac{v_0^2}{x_0} \left(1 - \frac{x}{x_0}\right)$$

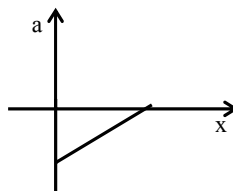

**Alternative:**  $a = -v \left(\frac{dv}{dx}\right)$ ; but  $dv/dx$  is negative and  $v$  is decreasing with the increase in  $x$ .

Hence 'a' should increase with increase of 'x'.

65. A particle is confined to rotate in a circular path with decreasing linear speed, then which of the following is correct?

- (A)  $\vec{L}$  (angular momentum) is conserved about the centre.  
 (B) only direction of angular momentum  $\vec{L}$  is conserved.  
 (C) It spirals towards the centre.  
 (D) its acceleration is towards the centre.

**Ans. B**

66. The atomic number ( $Z$ ) of an element whose  $k_\alpha$  wavelength is  $\lambda$  is 11. The atomic number of an element whose  $k_\alpha$  wavelength is  $4\lambda$  is equal to

- (A) 6 (B) 11  
 (C) 44 (D) 4

**Ans. A**Sol.  $(Z - 1)^2 \lambda = \text{constant}$ 

$$\therefore (10^2)\lambda = 4\lambda(Z - 1)^2 \Rightarrow Z = 6$$

67. The graph shown in the figure represents energy density  $E_\lambda$  versus  $\lambda$  for three sources sun, welding arc, tungsten filament. For  $\lambda_{\text{max}}$ , correct combination will be

- (A) 1 - Tungsten, 2 - Welding arc, 3 - Sun  
 (B) 1 - Sun, 2 - Tungsten, 3 - Welding arc.  
 (C) 1 - Sun, 2 - Welding arc, 3 - Tungsten  
 (D) 1 - Welding arc, 2 - Sun, 3 - Tungsten

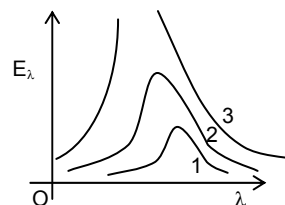
**Ans. A**

Sol. Temperature of sun would be maximum out of the given three

$$\text{as } \lambda_m T = \text{constant}$$

$$\lambda_m \text{ for Sun is minimum}$$

68.  $T_1$  is the time period of simple pendulum. The point of suspension moves vertically upwards according to  $y =$

$kt^2$ , where  $k = 1 \text{ m/s}^2$ . New time period is  $T_2$ , then  $\frac{T_1^2}{T_2^2} = ?$  ( $g = 10 \text{ m/s}^2$ )

- (A) 4/5 (B) 6/5  
 (C) 5/6 (D) 1

**Ans. B**

Sol. Acceleration of the point of suspension

$$a = \frac{d^2y}{dt^2} = 2k = 2 \text{ m/s}^2$$

$$T = 2\pi\sqrt{\frac{L}{g_{\text{eff}}}} \Rightarrow T_1 = 2\pi\sqrt{\frac{L}{10}} \text{ and } T_2 = 2\pi\sqrt{\frac{L}{12}}$$

$$\therefore \frac{T_1^2}{T_2^2} = \frac{6}{5}$$

IIT-JEE-2005-S-4

69. Which of the following does not have the same dimension?  
 (A) Electric flux, Electric field, Electric dipole moment  
 (B) Pressure, stress, Young's modulus  
 (C) Electromotive force, Potential difference, Electric voltage.  
 (D) Heat, Potential energy, Work done

Ans. A

70. A capacitor ( $C = 4.0 \mu\text{F}$ ) is connected through a resistor ( $R = 2.5 \text{ M}\Omega$ ) across a battery of negligible internal resistance of voltage 12 volts. The time after which the potential difference across the capacitor becomes three times to that of resistor is ( $\ln 2 = 0.693$ )  
 (A) 13.86 sec. (B) 6.48 sec.  
 (C) 3.24 sec. (D) 20.52 sec.

Ans. A

Sol.  $q = C\varepsilon \left(1 - e^{-\frac{t}{RC}}\right) \Rightarrow i = \frac{\varepsilon}{R} e^{-\frac{t}{RC}}$   
 $3V_R = V_C$   
 $\Rightarrow \varepsilon \left(1 - e^{-\frac{t}{RC}}\right) = 3\varepsilon e^{-\frac{t}{RC}} \Rightarrow e^{-t/RC} = 1/4$   
 $t/RC = 2\ln 2 \therefore t = 20 \times (0.693) = 13.86 \text{ sec}$

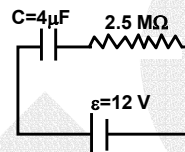

71. A photon of energy 10.2 eV collides inelastically with a Hydrogen atom in ground state. After a certain time interval of few micro seconds another photon of energy 15.0 eV collides inelastically with the same hydrogen atom, then the observation made by a suitable detector is  
 (A) 1 photon with energy 10.2 eV and an electron with energy 1.4 eV  
 (B) 2 photon with energy 10.2 eV  
 (C) 2 photon with energy 1.4 eV  
 (D) one photon with energy 3.4 eV and 1 electron with energy 1.4 eV

Ans. A

Sol. 10.2 eV photon on collision will excite H-atom to first excited state but Hydrogen atom will return to ground state before next collision. Second photon will provide ionization energy to Hydrogen atom, i.e., electron will be ejected with energy = 1.4 eV

72. In a resonance tube with tuning fork of frequency 512Hz, first resonance occurs at water level equal to 30.3 cm and second resonance occurs at 63.7 cm. The maximum possible error in the speed of sound is  
 (A) 51.2 cm/s (B) 102.4 cm/s  
 (C) 204.8 cm/s (D) 153.6 cm/s

Ans. C

Sol.  $l_1 + e = \frac{v}{4f}$  and  $l_2 + e = \frac{3v}{4f}$   
 $l_2 - l_1 = \frac{2v}{4f}$   
 $\frac{\Delta(l_2 - l_1)}{(l_2 - l_1)} = \frac{\Delta v}{v}$   
 $\Delta v = 2f\Delta(l_2 - l_1) = 2f(\Delta l_1 + \Delta l_2)$  (For maximum error)  
 $= 2 \times 512 \times 0.2 = 204.8 \text{ cm/s.}$

73. A thin concave and a thin convex lens are in contact. The ratio of the magnitude of power of two lenses is 2/3 and focal length of combination is 30cm, then the focal length of individual lenses are  
 (A) - 15 cm, 10 cm (B) - 75 cm, 50 cm  
 (C) 75 cm, - 50 cm (D) 75 cm, 50 cm

Ans. A

Sol.  $\left| \frac{P_{\text{concave}}}{P_{\text{convex}}} \right| = \frac{2}{3}$

$$\frac{1}{F} = \frac{1}{f_{\text{concave}}} + \frac{1}{f_{\text{convex}}}$$

$$\frac{1}{30} = \frac{-2}{3f} + \frac{1}{f} = \frac{1}{3f} \Rightarrow f = 10 \text{ cm, where } f \text{ is focal length of convex lens}$$

74. Which of the following process does not occur through convection  
 (A) Boiling of water (B) Land breeze and Sea breeze  
 (C) Circulation of air around furnace (D) Heating of glass bulb through filament

**Ans. D**

Sol. Heating of glass bulb is by radiation.

75. A tank of height 33.25 cm is completely filled with liquid ( $\mu = 1.33$ ). An object is placed at the bottom of tank on the axis of concave mirror as shown in the figure. Image of the object is formed 25 cm below the surface of the liquid, then focal length of the mirror is

- (A) 10 cm (B) 15 cm  
 (C) 20 cm (D) 25 cm

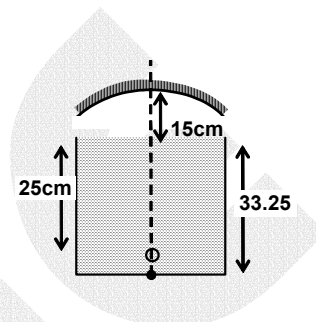

**Ans. C**

Sol. After first refraction, position of the image =  $\frac{33.25}{1.33} = 25\text{cm}$

$$\text{From reflection, } \frac{1}{f} = \frac{1}{v} - \frac{1}{u} = \frac{1}{v} - \frac{1}{40}$$

$$\text{From second refraction position of the object} = \frac{25}{1.33}$$

$$\frac{1}{f} = -\frac{1}{15 + \frac{25}{1.33}} - \frac{1}{40} \Rightarrow f = -18.31 \text{ cm}$$

Hence magnitude of focal length of convex lens is 18.31 cm.  
 The nearest possible matching answer is 20 cm.

76. In YDSE, an electron beam is used to obtain interference pattern. If speed of electron is increased then  
 (A) no interference pattern will be observed.  
 (B) distance between two consecutive fringes will increase.  
 (C) distance between two consecutive fringes will decrease.  
 (D) distance between two consecutive fringes remains same.

**Ans. C**

Sol.  $\lambda = \frac{h}{mv}$

$v$  is increased,  $\lambda$  is decreased.

$$\beta = \lambda D/d \Rightarrow \beta \text{ decreases.}$$

77. A spherical body of area  $A$  and emissivity  $e = 0.6$  is kept inside a perfectly black body. Total heat radiated by the body at temperature  $T$

- (A)  $0.4 e AT^4$  (B)  $0.8eAT^4$   
 (C)  $0.6 eAT^4$  (D)  $1.0eAT^4$

**Ans. D**

Sol. When a non black body is placed inside a hollow enclosure the total radiation from the body is the sum of what it would emit in the open (with  $e < 1$ ) and the part  $(1-e)$  of the incident radiation from the walls reflected by it. The two add up to a black body radiation. Hence the total radiation emitted by the body is  $1.0\sigma AT^4$ . Probably in the examination paper ' $\sigma$ ' is misprinted as ' $e$ '

78. An open organ pipe resonated with frequency ' $f_1$ ' and  $2^{\text{nd}}$  harmonic. Now one end is closed and the frequency is slowly increased then it resonates with frequency  $f_2$  and  $n^{\text{th}}$  harmonic then

- (A)  $n = 3, f_2 = \frac{3}{4} f_1$  (B)  $n = 5, f_2 = \frac{3}{4} f_1$   
 (C)  $n = 3, f_2 = \frac{5}{4} f_1$  (D)  $n = 5, f_2 = \frac{5}{4} f_1$

IIT-JEE-2005-S-6

**Ans. D**

$$\text{Sol. } f_1 = \frac{1}{\ell} \sqrt{\frac{B}{\rho}}$$

$$f_2 = \frac{n}{4\ell} \sqrt{\frac{B}{\rho}}$$

$$\frac{f_1}{f_2} = \frac{4}{n} \Rightarrow f_2 = \frac{n}{4} f_1$$

For the first resonance  $n = 5$ ,  $f_2 = \frac{5}{4} f_1$  (as frequency increases)

79. Temperature of a gas is  $20^\circ\text{C}$  and pressure is changed from  $1.01 \times 10^5$  Pa to  $1.165 \times 10^5$  Pa. If volume is decreased isothermally by 10%. Bulk modulus of gas is

(A)  $1.55 \times 10^5$

(B)  $0.155 \times 10^5$

(C)  $1.4 \times 10^5$

(D)  $1.01 \times 10^5$

**Ans. A**

$$\text{Sol. } B = -\Delta P / (\Delta V / V) = -\frac{(1.165 - 1.01) \times 10^5}{0.1} = 1.55 \times 10^5$$

80. A galvanometer with resistance  $100\Omega$  is converted to ammeter with a resistance of  $0.1\Omega$ . The galvanometer shows full scale deflection with a current of  $100\mu\text{A}$ . Then the minimum current in the circuit for full scale deflection of galvanometer will be

(A)  $100.1\text{mA}$

(B)  $10.01\text{mA}$

(C)  $1.001\text{mA}$

(D)  $0.1001\text{mA}$

**Ans. A**

$$\text{Sol. } 0.1 = \frac{100R'}{100 + R'} \Rightarrow R' = \frac{100}{1001}$$

$$(100)(100 \times 10^{-6}) = R'(I - 100 \times 10^{-6})$$

$$\therefore I = 100.1 \text{ mA}$$

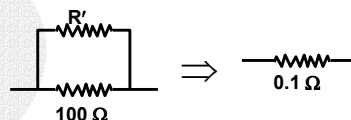

81. One calorie is defined as the heat required to raise the temperature of 1 gm of water by  $1^\circ\text{C}$  in a certain interval of temperature and at certain pressure. The temperature interval and pressure is

(A)  $13.5^\circ\text{C}$  to  $14.5^\circ\text{C}$  & 76 mm of Hg

(B)  $6.5^\circ\text{C}$  to  $7.5^\circ\text{C}$  & 76 mm of Hg

(C)  $14.5^\circ\text{C}$  to  $15.5^\circ\text{C}$  & 760 mm of Hg

(D)  $98.5^\circ\text{C}$  to  $99.5^\circ\text{C}$  & 760 mm of Hg

**Ans. C**

Sol. By definition.

82. If a star converts all of its Helium into oxygen nucleus, find the amount of energy released per nucleus of oxygen. He = 4.0026 amu, O = 15.9994 amu

(A) 7.26 MeV

(B) 7 MeV

(C) 10.24 MeV

(D) 5.12 MeV

**Ans. C**

$$\text{Sol. } E = \Delta mc^2 = [4 \times 4.0026 - 15.9994] \times 931.5 = 10.24 \text{ MeV}$$

83. Two litre of water at initial temperature of  $27^\circ\text{C}$  is heated by a heater of power 1 kW. If the lid of kettle is opened, then heat is lost at the constant rate of 160 J/s. Find the time required to raise the temperature of water to  $77^\circ\text{C}$  with the lid open (Specific heat of water  $4.2 \text{ kJ/kg}$ )

(A) 5 min 40 sec

(B) 14 min 20 sec

(C) 8 min 20 sec

(D) 16 min 10 sec

**Ans. C**

$$\text{Sol. } \text{Rate of heat gain} = 1000 - 160 = 840 \text{ J/s}$$

$$\therefore \text{Required time} = \frac{2 \times 4.2 \times 10^3 \times (77 - 27)}{840} = 500 \text{ sec} = 8 \text{ min } 20 \text{ sec}$$

84. Ideal gas is contained in a thermally insulated and rigid container and it is heated through a resistance  $100\Omega$  by passing a current of  $1A$  for five minutes, then change in internal energy of the gas is
- (A)  $0\text{ kJ}$  (B)  $30\text{ kJ}$   
(C)  $10\text{ kJ}$  (D)  $20\text{ kJ}$

**Ans. B**

Sol.  $\Delta W = 0 \therefore \Delta Q = \Delta U$

$$\Delta Q = \Delta U = I^2 R \Delta t = (1)^2 (100) (5 \times 60) = 30\text{ kJ}$$

*Analyse your performance in Screening Test for evaluation of your preparation for Mains. A comprehensive analysis of your preparation on different topics would be couriered to you. Fill this sheet as per answers you have made in the IIT-JEE Screening Examination as per the sequencing provided in the solution booklet and send to nearest **FITJEE**'s office immediately.*