

FORMULAE

You may find the following formulae useful.

$$\text{power} = \frac{\text{work done}}{\text{time taken}}$$

$$P = \frac{W}{t}$$

$$\text{power} = \frac{\text{energy transferred}}{\text{time taken}}$$

$$P = \frac{W}{t}$$

$$\text{frequency} = \frac{1}{\text{time period}}$$

$$f = \frac{1}{T}$$

Where necessary, assume the acceleration of free fall, $g = 10 \text{ m/s}^2$.



Leave blank

1. (a) The nucleus of an atom of nitrogen-14 can be described by the symbol

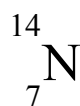

Choose from the following numbers to complete the table:

7 14 21

Each number may be used once, more than once or not at all.

number of protons in the nucleus	
number of electrons in the atom	
number of neutrons in the nucleus	

(3)

(b) Nitrogen-14 and nitrogen-15 are isotopes of nitrogen.

Complete the sentence.

Nitrogen-14 and nitrogen-15 both have the same number
of in the nucleus but a different number
of in the nucleus.

(2)

Q1

(Total 5 marks)



2. A student hangs weights from a spring and notes the extension.

(a) The weight produces a force within the spring.

Use a word from the box to complete the sentence.

curved horizontal straight vertical

When Hooke's Law is obeyed, the graph of extension against force is a line.

(1)

(b) Some of the student's results are shown below.

Weight / N	0	0.1	0.2	0.3	0.4	0.5
Extension / mm	0	5	10		20	25

Predict the value of the extension, in mm, when the weight is 0.3 N.

Extension = mm
(1)

(c) Another student wanted to use the table of results in part (b) to predict the extension of the spring when a weight of 200 N is hung from it.

Give **two** reasons why the table cannot be used to predict the extension in this case.

1
.....
2
.....

(2)



Leave
blank

(d) The graph shows the force-extension graph obtained from another experiment.

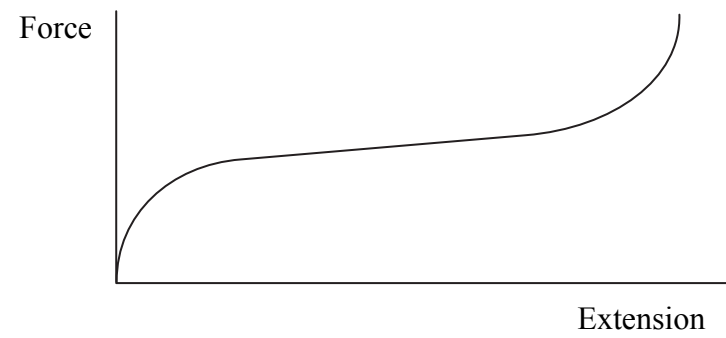

(i) How can you tell that this experiment did not involve a spring?

.....
.....
(1)

(ii) Suggest a material that would be used to produce the graph shown.

.....
(1)

(Total 6 marks)

Q2



3. The diagram shows a three-pin plug with the top removed.
The earth wire and the fuse are two of the safety features.

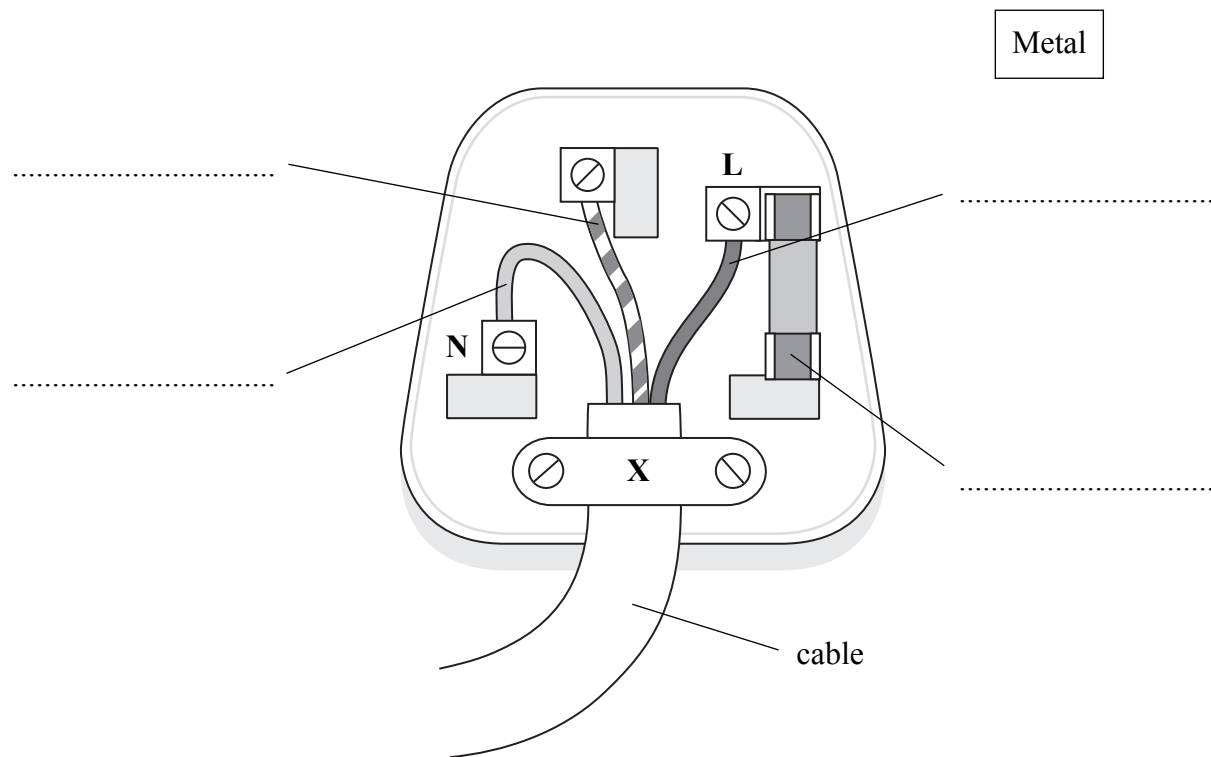

(a) (i) Most of the plug is made from plastic.
Identify a part of the plug that must be made from metal.
Draw a line between it and the box labelled 'Metal'. (1)

(ii) Add the labels, **earth wire** and **fuse**, on the appropriate dotted lines on the diagram. (2)

(iii) State why some appliances do not need an earth wire.
.....
..... (1)

(iv) Explain what happens to a fuse when the current in it is too large.
.....
.....
..... (2)



Leave blank

4. (a) A student pushing a trolley enters a shop.
The diagram shows a distance-time graph for the trolley.
The two sections of the graph are labelled **A** and **B**.

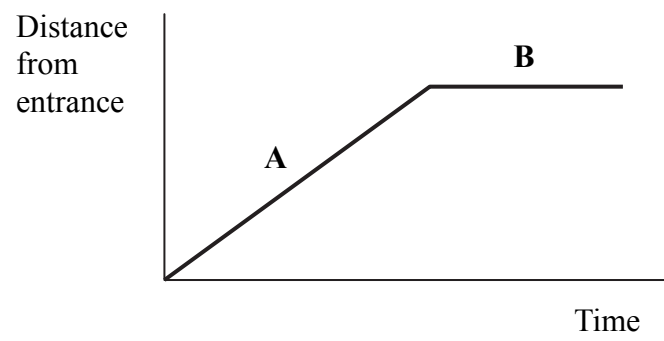

- (i) Describe the motion of the trolley in section **A**.

..... (1)

- (ii) Describe the motion of the trolley in section **B**.

..... (1)



Leave blank

- (b) The student continues to push the trolley in a straight line **away** from the entrance. The diagram below shows another student's attempt at drawing the complete distance-time graph for the trolley. It has five sections, labelled **A** to **E**.

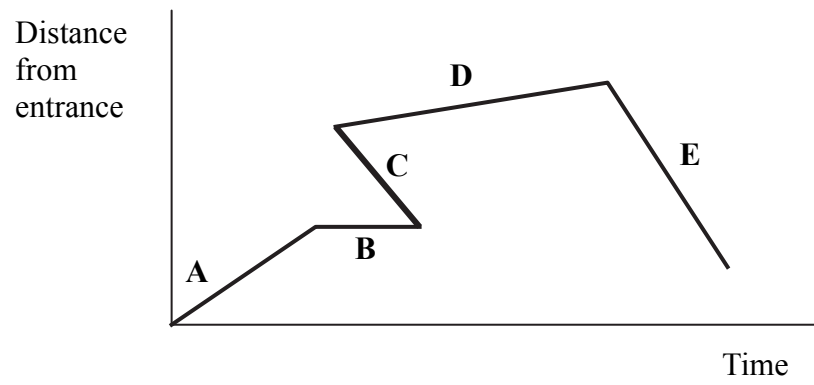

Two sections are **incorrect**.

Identify each incorrect section and explain why it is incorrect.

Section.....

Explanation

.....

Section

Explanation

.....

(4) Q4

(Total 6 marks)



5. The diagram shows a wave and five measurements **A**, **B**, **C**, **D** and **E**.

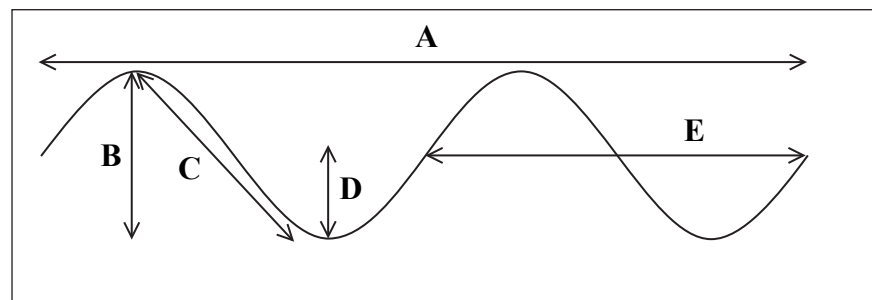

(a) Complete the sentences by choosing the correct letters from **A**, **B**, **C**, **D** and **E**.

The amplitude is represented by

The wavelength is represented by

(2)

(b) The type of wave shown in the diagram is a transverse wave.

(i) Name another type of wave.

..... **(1)**

(ii) Give an example of the type of wave you named in part (b)(i).

..... **(1)**



6. (a) The diagram shows the airflow in a room heated by a convection heater.

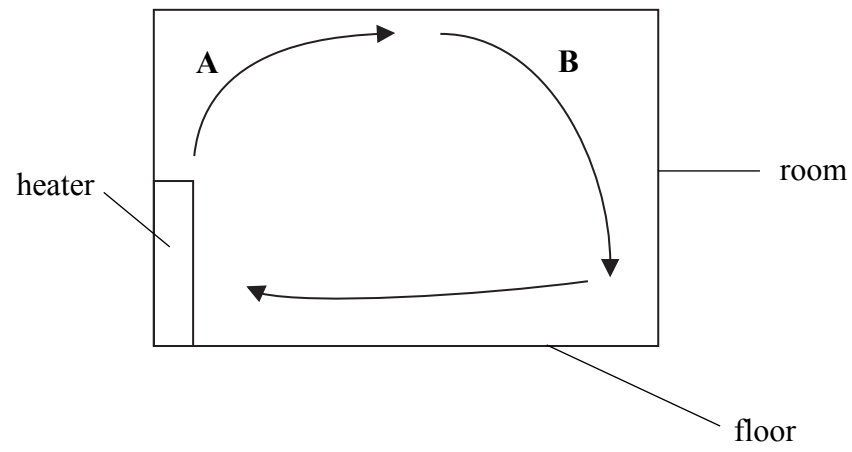

(i) At **A** hot air is rising.

Describe what is happening at **B**.

.....
.....

(2)

(ii) Convection is one method of heat energy transfer.

Name **two** other methods of heat energy transfer.

1

2

(2)



Leave
blank

(b) Heat energy can escape through the external walls of a hot room.

Use words or terms from the box to complete the sentences.

absorber	conducting	copper
fibre-glass	insulator	non-conducting

To reduce the heat energy escaping through the walls, the walls are filled with

a material known as an

.....

An example of such a material is

(3) **Q6**

(Total 7 marks)

13

Turn over



7. (a) State the equation which relates density, mass and volume.

.....
.....

(1)

(b) A student wants to find the density of a solid metal cube of length 2 cm.

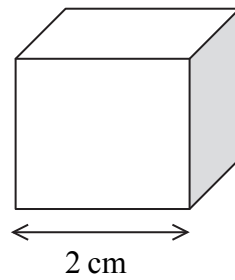

(i) State the equipment that she would need to measure the mass and the length of the cube.

Mass

Length

(2)

(ii) The student finds that the density is 8.0 g/cm^3 .

State the density of a solid metal cube of the same material of length 4 cm.

Density = g/cm^3

(1)



Leave
blank

(c) The student also wants to find the density of the stone shown below.

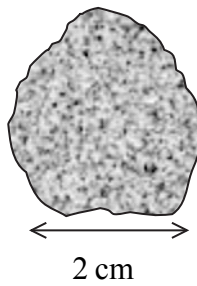

(i) State the equipment that she would need to find the volume of the stone.

.....
(1)

(ii) The density of water is 1.0 g/cm^3 .

State the problem that would occur in trying to determine the volume of an object if its density is less than 1.0 g/cm^3 .

.....
.....
(1)

(Total 6 marks)

Q7



8. (a) State an equation which relates voltage, current and resistance.

.....
(1)

(b) There is an electric current in a copper wire.

(i) Complete the sentence.

This electric current is the rate of flow of
(1)

(ii) The copper wire is replaced by an aluminium wire.
This wire has the same thickness and the same length but a greater resistance.

What effect, if any, does this have on the electric current?
.....
(1)

(c) The following circuit diagram shows the places where a student measures the current in a circuit.

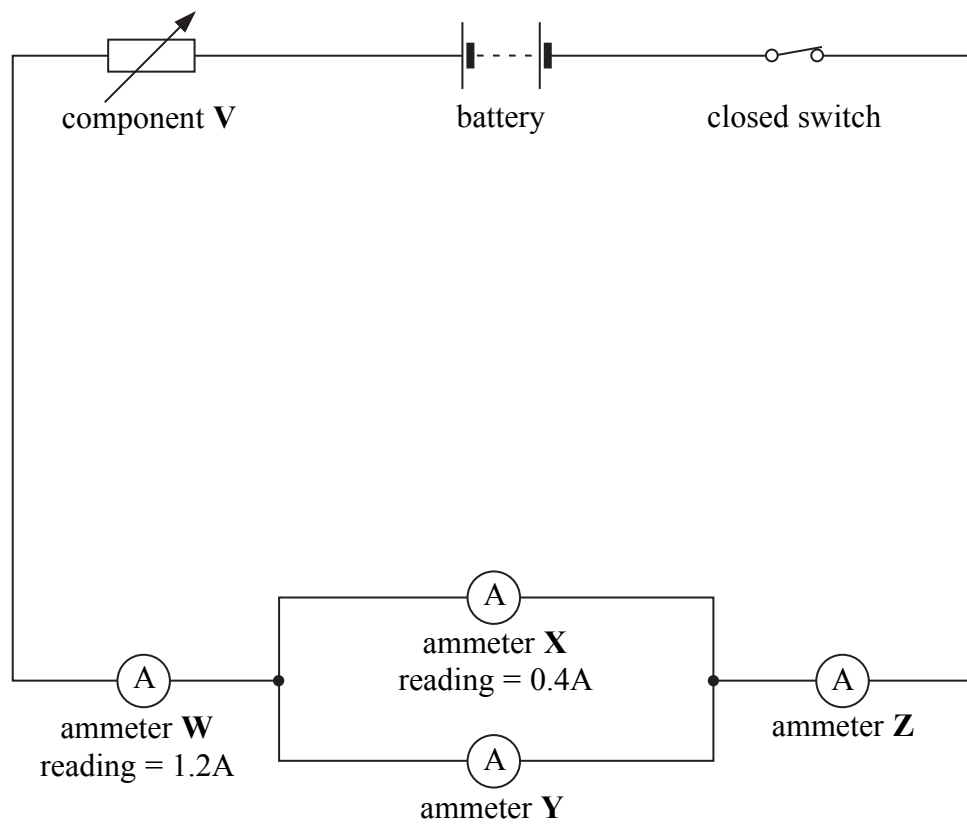

(i) Identify component **V**.

.....
(1)

(ii) State the reading in amps on

ammeter **Y** reading =A

ammeter **Z** reading =A

(2)

(d) The following circuit diagram shows how a toymaker connects the lights in a toy house.

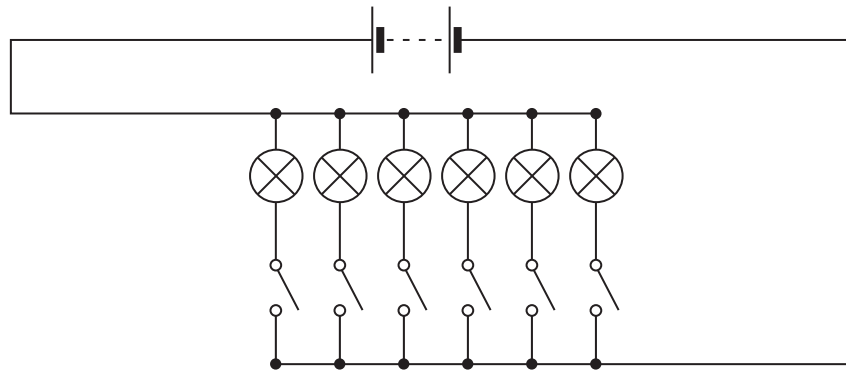

(i) Complete the sentence.

The lights in the toy house are connected in
(1)

(ii) Suggest **one** advantage of connecting the lights in this way.

.....
.....
(1)

(Total 8 marks)

Q8



9. (a) The box contains the names of seven parts of the electromagnetic spectrum.

radio waves microwaves infra-red visible light ultraviolet X-rays gamma rays

(i) Describe the order in which they have been written.

.....
.....
(1)

(ii) The parts are all transverse waves.

State **one** other property which they all have in common.

.....
.....
(1)

(b) Some of the radiation from parts of the electromagnetic spectrum can damage human beings.

Draw lines connecting each of the four parts listed below with the damage caused.

Part	Damage caused
microwaves ●	● mutations and cancers
infra-red radiation ●	● internal heating of body tissues
ultraviolet radiation ●	● skin burns
gamma radiation ●	● damage to surface cells and blindness

(3)

(c) Microwaves can be used for cooking.

Give **one** other use for microwaves.

.....
(1)

(Total 6 marks)

Q9



BLANK PAGE

Turn over for Question 10



10. (a) A geologist has discovered a mineral which is radioactive.
The mineral is unstable. It emits ionising radiation in the form of alpha particles, beta particles and gamma radiation.

(i) Describe the nature of beta particles.

.....
.....
(1)

(ii) The emissions are **random**.

What does random mean?

.....
.....
(1)

(iii) Ionising radiations can be detected by using photographic film.

What else can be used to detect them?

.....
(1)



Leave blank

(b) The graph shows how the activity of a radioactive source varies with time. Use the graph to calculate the half-life of this radioactive source in millions of years.

Show clearly on the graph how you do this.

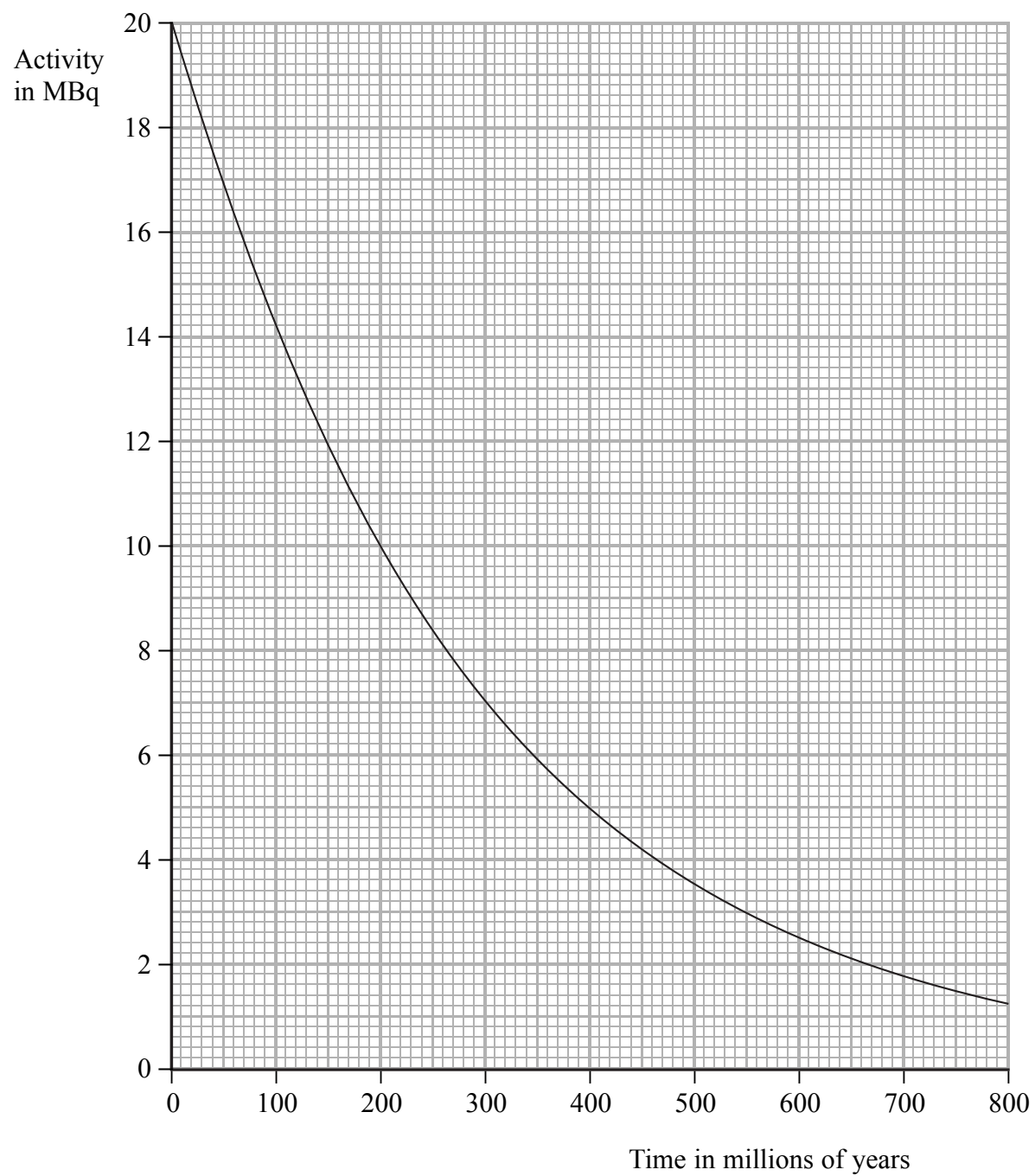

Half-life of source = million years
(2)

(Total 5 marks)

Q10

21

Turn over



11. Energy transfers take place during running.



(a) The box contains the descriptions of nine different forms of energy.

chemical	electrical	kinetic	light	nuclear
elastic potential	gravitational potential	sound	thermal	

Use the best descriptions from the box to complete the following sentences.

(i) The food eaten and the oxygen breathed provide the runner with energy. **(1)**

(ii) This energy is used in the runner's muscles to give heat energy and energy. **(1)**



Leave
blank

(b) In four minutes, a runner transfers 30 000 joules of useful energy output.

(i) Calculate the useful power output of the runner.
Show how you arrive at your answer and state the unit.

.....
.....

Useful power output =
(3)

(ii) State the relationship between efficiency and useful energy output.

.....

(1)

Q11

(Total 6 marks)



12. A ticker timer is a device which makes dots on a paper tape.
 A student fastens one end of the tape to a toy car and uses the ticker timer to record the motion of the toy car.
 Her investigation is shown below.

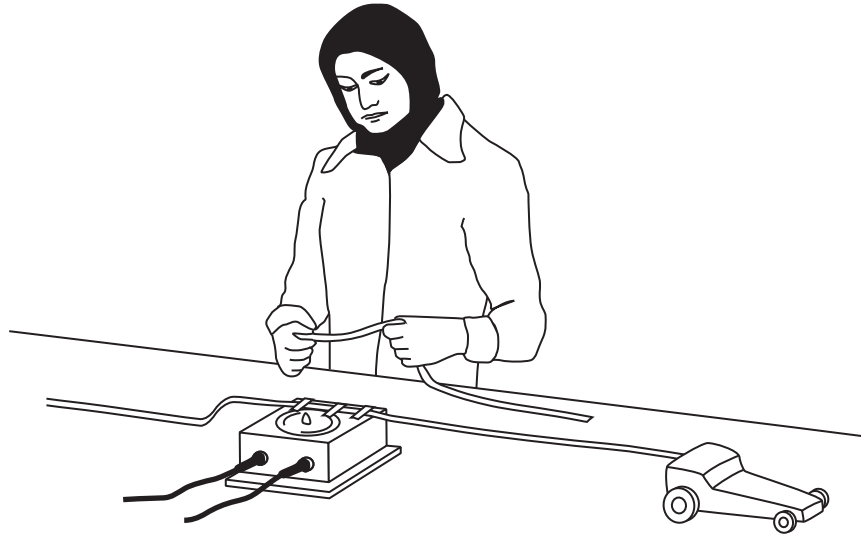

Part of the tape from the student's investigation is shown in the following drawing.

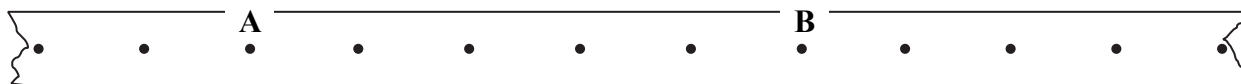

(a) (i) The ticker timer produces dots at a steady rate of 50 dots per second.
 Calculate how long, in seconds, it took the toy car to travel from **A** to **B**.

.....

Time taken = s
(2)

(ii) Distance **A** to **B** is 73 mm.
 Calculate the average speed, in mm/s, of the car as it travelled this distance.

.....

Average speed = mm/s
(2)



Leave
blank

- (b) The diagram shows the toy car and the arrow shows where its weight acts.
Put an **X** on the diagram to show the position of the centre of gravity of the car.
The centre of the **X** should be at the centre of gravity.

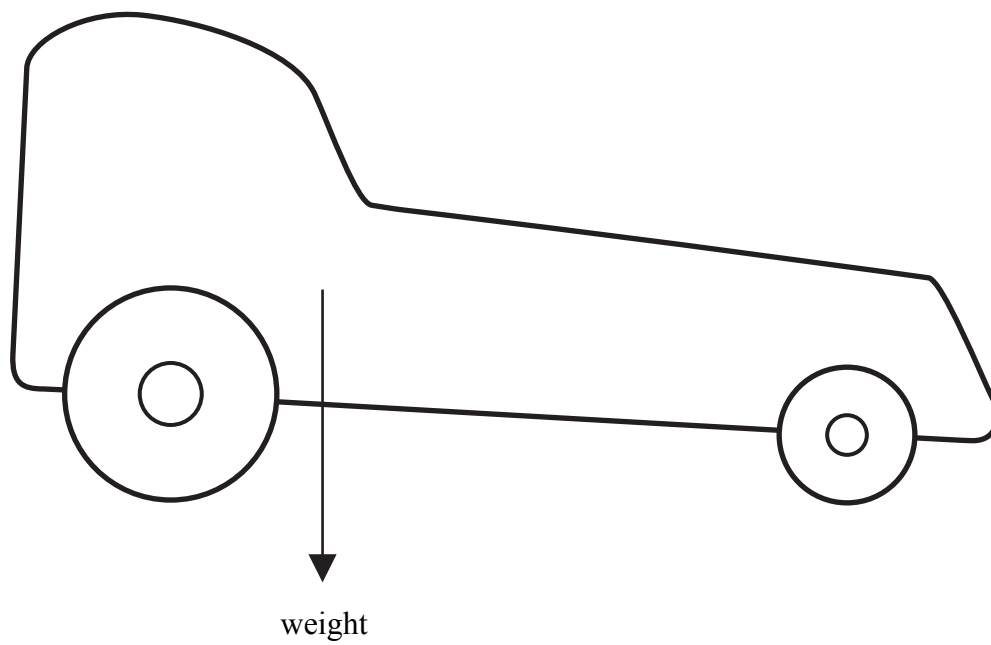

(1)

Q12

(Total 5 marks)

TOTAL FOR PAPER: 75 MARKS

END



BLANK PAGE



BLANK PAGE



BLANK PAGE

