



## FORMULAE

You may find the following formulae useful.

$$\text{power} = \frac{\text{work done}}{\text{time taken}}$$

$$P = \frac{W}{t}$$

$$\text{power} = \frac{\text{energy transferred}}{\text{time taken}}$$

$$P = \frac{W}{t}$$

$$\text{frequency} = \frac{1}{\text{time period}}$$

$$f = \frac{1}{T}$$

Where necessary, assume the acceleration of free fall,  $g = 10 \text{ m/s}^2$ .



Leave blank

1. (a) The chart gives the names of different parts of the electromagnetic spectrum in order. Add the missing name.

Radio waves	Micro-waves		Visible	Ultra-violet	X-rays	Gamma rays
-------------	-------------	--	---------	--------------	--------	------------

(1)

- (b) Use words from the box to complete the sentences. You may use each word once, more than once or not at all.

frequency    speed    wavelength

Microwaves have a longer ..... than ultraviolet

but a lower .....

Both waves have the same ..... in free space.

(3)

- (c) State a use for microwaves.

.....  
(1)

- (d) State a harmful effect of microwaves.

.....  
(1)

- (e) Name a part of the electromagnetic spectrum that does not usually have a harmful effect on the human body.

.....  
(1)

(Total 7 marks)

Q1



**BLANK PAGE**



2. (a) The distance–time graphs shown represent different types of motion.

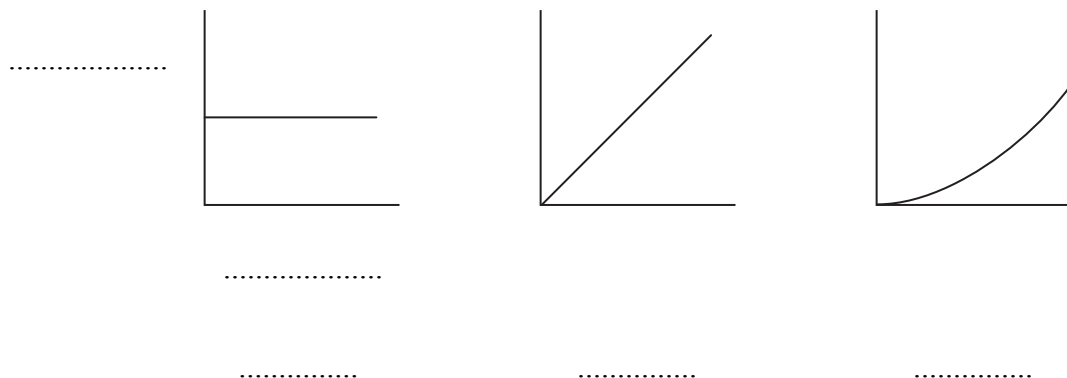

(i) Label the axes of the first graph, on the dotted lines provided.

(1)

(ii) Four types of motion are listed.

- A acceleration
- B deceleration
- C constant speed
- D stationary

Label the three graphs **A**, **B**, **C** or **D**, on the dotted lines provided.

(3)

(b) The speed of light is 300 megametres per second.  
How many metres (m) are there in a megametre (Mm)?

1 Mm = ..... m

(1)

Q2

(Total 5 marks)



3. (a) In the diagram, heat transfers from the hand to the ice by conduction.

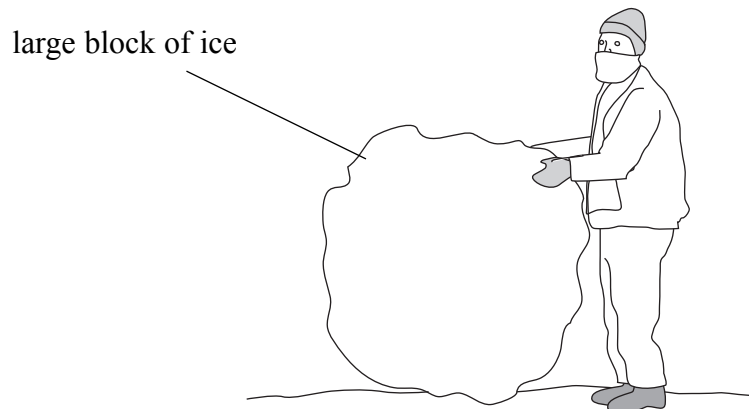

Name **two** other methods of heat transfer.

..... and ..... (2)

(b) After running a marathon, a runner is wrapped in a blanket made from a light shiny material.

Use words from the box to complete the sentence.

<b>absorber</b> <b>conduction</b> <b>radiation</b> <b>reflector</b>
---

The blanket is a good ..... of heat  
and so reduces heat loss by .....

(2)



Leave  
blank

(c) The diagram shows a building on a cold snowy day. Heat is lost from the building.



(i) Name **two** parts of a building through which heat might be lost.

1 .....

2 .....

**(2)**

(ii) Name an insulator that could be used to reduce heat loss from the house.

.....

**(1)**

**(Total 7 marks)**

**Q3**



**BLANK PAGE**





Leave  
blank

4. (a) The nucleus of a neutral carbon-14 atom can be represented by the symbol



Put a cross (☒) in the correct **two** boxes to show which of the following are correct.

This information can be used to give the number of

- A  electrons in the neutral atom  
B  neutrons in the neutral atom  
C  protons in the neutral atom

(2)

(b) The symbol for uranium-234 is  ${}^{234}_{92}\text{U}$ .

Calculate the number of neutrons in an atom of uranium-234.

.....

Number of neutrons = .....

(2)

(c) (i) Complete the sentence.

Isotopes have the same number of ..... but a  
different number of .....

(2)

(ii) Circle the pair of isotopes shown below.



(1)

Q4

(Total 7 marks)



5. A student connects the series circuit shown.

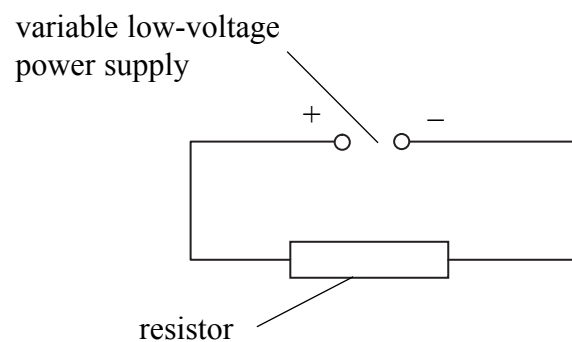

The diagram below shows the setting on the dial of the power supply.

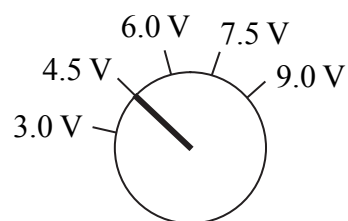

(a) The student adds another resistor in series with the first one. This doubles the resistance of the circuit. What happens to the value of the current in the circuit?

.....  
.....  
(2)

(b) How can the student get back to the original value of the current without changing the resistance of the circuit?

.....  
.....  
(2)



(c) The student then connects the circuit shown below.

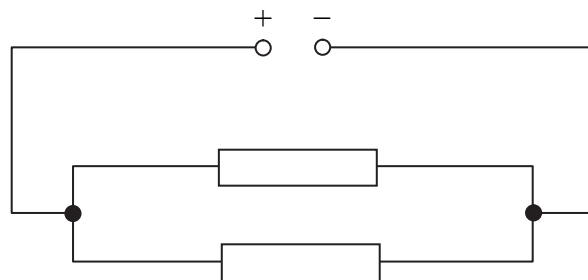

The resistors in this circuit are connected in ..... (1)

(d) The student is given another circuit component. Its symbol is shown below.

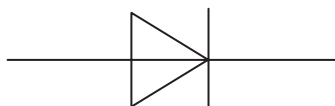

(i) Name this component.  
..... (1)

(ii) Draw this component connected into the circuit in (c) so that there is no current anywhere in the circuit. (2)

(Total 8 marks)

Q5



N 3 2 7 2 2 A 0 1 1 2 0

6. The driver of a car needs to stop suddenly. She takes a short time to think and then applies the brakes.  
The diagram shows her total stopping distance of 12 m when she is driving at a speed of 10 m/s.

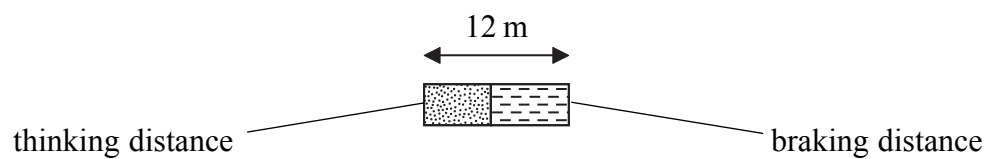

- (a) Tick (✓) **one** of the following factors which affects her **thinking time**.

Road condition	
Reaction time	
Speed of car	

(1)

- (b) State the equation which relates average speed, distance moved and time.

.....  
(1)

- (c) Tick (✓) each of the following factors that affect her **braking distance**.

Road condition	
Reaction time	
Speed of car	

(2)

- (d) Later on she is driving at a speed of 20 m/s and has to stop suddenly. The diagram shows her total stopping distance of 36 m when she is driving at a speed of 20 m/s.

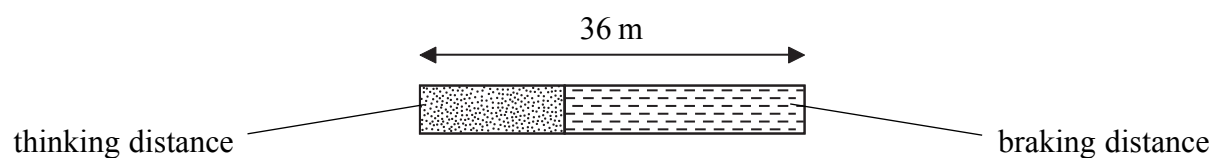

Why is her thinking distance greater for 20 m/s than for 10 m/s?

.....  
(1)



(e) The table shows how thinking distance depends on speed.

speed in m/s	5	10	15	20	25
thinking distance in m	3	6	9	12	15

(i) Plot the points on the grid. One point is already plotted. Draw the best straight line for the plotted points.

Thinking distance  
in metres

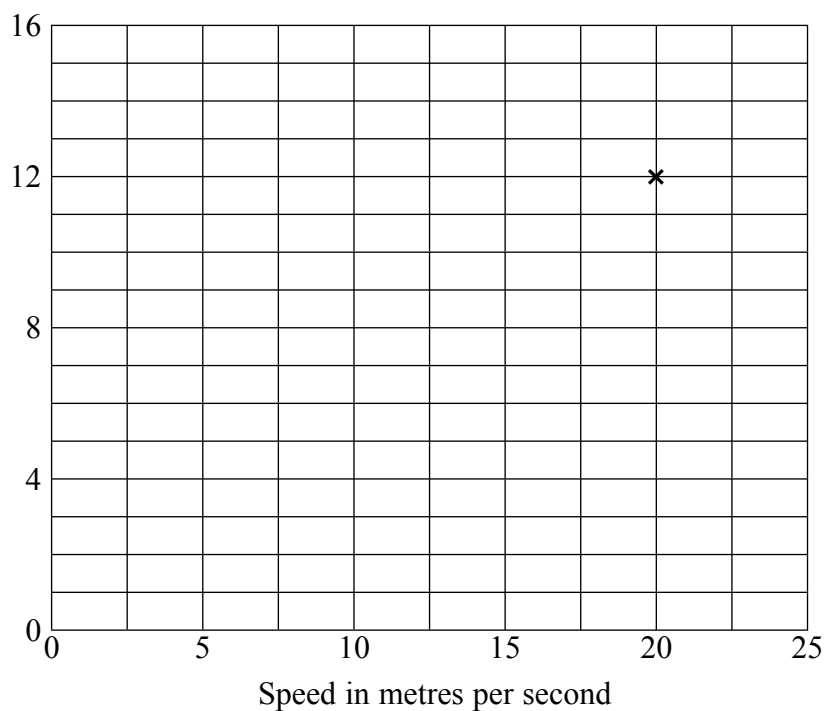

(3)

(ii) Use your graph to find the thinking distance for a speed of 12.5 m/s.

..... (1)

(iii) In the diagram opposite, the total stopping distance at a speed of 20 m/s is shown to be 36 m. Use the shaded data from the table above to find the braking distance in metres at a speed of 20 m/s.

.....

Braking distance at a speed of 20 m/s = ..... m (2)

(Total 11 marks)

Q6

--	--



7. The diagram shows an electric circuit.

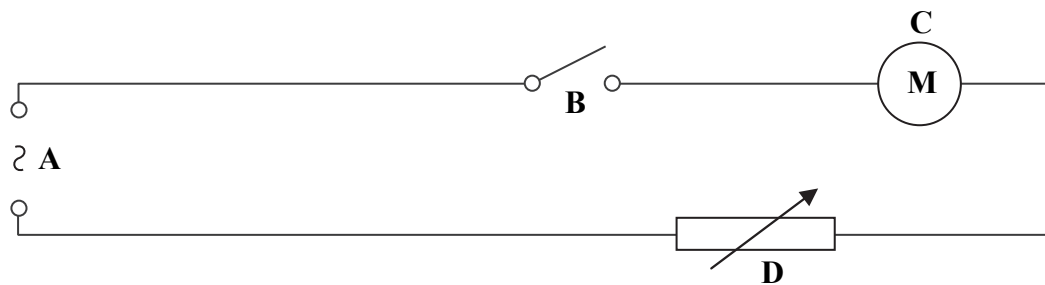

(a) What do the symbols, **A**, **B**, **C** and **D**, represent?

**A** ..... (1)

**B** ..... (1)

**C** ..... (1)

**D** ..... (1)

(b) A student connects two meters to **(M)** as shown.

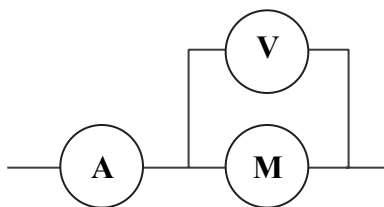

Complete the table to name each meter and what it measures.

Meter	Name	What it measures
Ⓥ	.....	This meter measures the ..... across <b>(M)</b> .
Ⓐ	.....	This meter measures the ..... in <b>(M)</b> .

(2)

Q7

(Total 6 marks)



8. The diagram shows a fisherman standing in water.

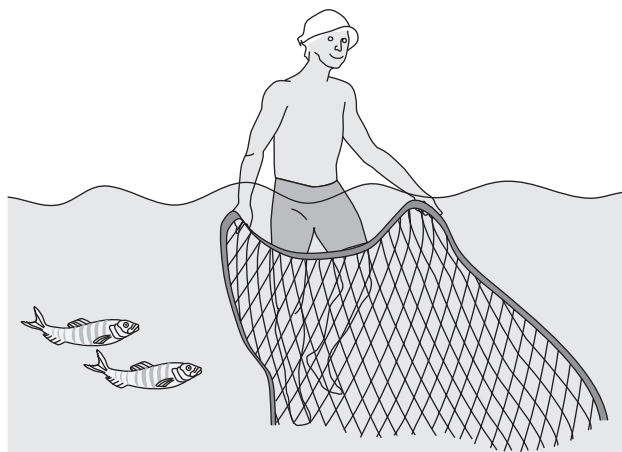

(a) In 8 seconds, 4 complete waves pass the fisherman.

Calculate the frequency of the waves and give the unit.

.....

Frequency = ..... (2)

(b) These water waves are transverse waves.

Name **one** other example of a transverse wave.

..... (1)

(c) Complete the sentence.

Waves can transfer energy and ..... without transferring matter. (1)

(d) What is meant by the time period of a wave?

.....

.....

..... (2)

(Total 6 marks)

Q8



9. The diagram shows an electric fan.

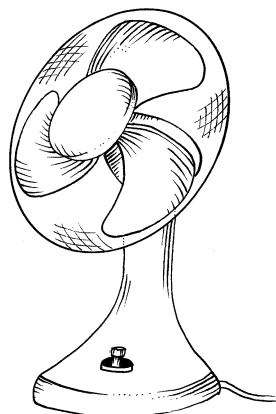

(a) Complete the sentences.

The useful energy output of the fan is ..... energy.

Energy is wasted as ..... energy and as

..... energy.

(2)

(b) State the equation for efficiency.

Efficiency =

(1)

(c) The useful power output of the fan is 50 watts.

Use the equation

$$\text{power} \times \text{time taken} = \text{work done}$$

to calculate the useful work done by the fan in 15 minutes and give the unit.

.....  
.....

Useful work = .....

(3)

(Total 6 marks)

Q9





**BLANK PAGE**



N 3 2 7 2 2 A 0 1 7 2 0

10. (a) Name **one** source of background radiation.

..... (1)

(b) The diagram shows a Geiger-Muller detector connected to a count rate meter. The count rate from a radioactive source is measured with different absorbers present.

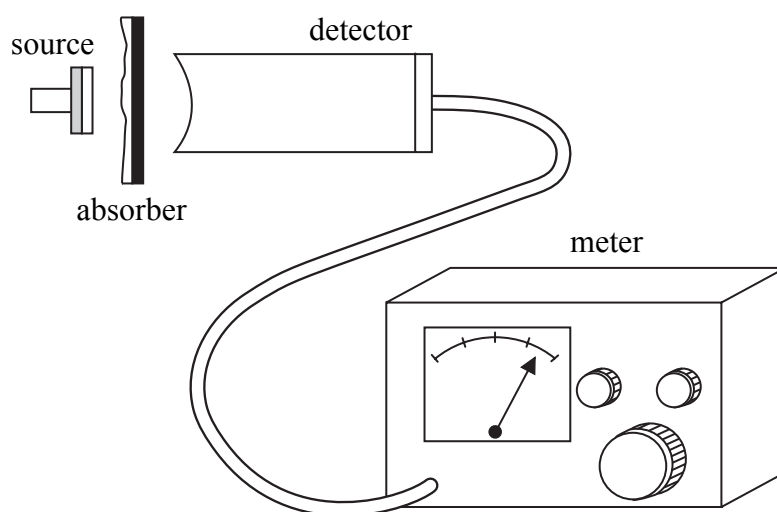

The table shows the results.

Absorber	Average count rate (counts per second) [after allowing for background radiation]
no absorber [apart from 10 mm of air]	41
card 1 mm thick	24
metal 3 mm thick	0



Leave  
blank

Explain how the results show that the source

(i) emits alpha ( $\alpha$ ) radiation,

.....  
.....

**(1)**

(ii) emits beta ( $\beta$ ) radiation,

.....  
.....

**(1)**

(iii) does **not** emit gamma ( $\gamma$ ) radiation.

.....  
.....

**(1)**

(c) A source has a half-life of 15 minutes. When the activity of the source is measured it is 400 megabecquerels (MBq).

Estimate the activity in MBq of the source after one hour.  
Show your working.

.....  
.....

Activity = ..... MBq  
**(2)**

**(Total 6 marks)**

**Q10**



Leave blank

11. (a) Explain why it may be dangerous to switch on a light when your hands are wet.

.....  
.....  
.....

(2)

(b) Many electrical appliances have a metal casing.

A live wire comes into contact with the metal casing.  
Explain how an earth wire and a fuse prevent the user receiving an electric shock.

Earth wire .....

.....

Fuse .....

.....

(2)

(c) The resistance of a person's body is 10 000 ohms.  
A current of 0.020 amps will give the person a serious electric shock.

Use the equation

$$\text{voltage} = \text{current} \times \text{resistance}$$

to calculate the minimum voltage in volts which will cause this.

.....

.....

Minimum voltage = ..... V

(2)

Q11

(Total 6 marks)

**TOTAL FOR PAPER: 75 MARKS**

**END**

