

THE PERIODIC TABLE

	Group																																																																																																																			
	1	2	3	4	5	6	7	0																																																																																																												
Period																																																																																																																				
1	<table border="1" style="width: 100%; border-collapse: collapse;"> <tr> <td style="text-align: center;">1</td> <td style="text-align: center;">1</td> <td colspan="6"></td> <td style="text-align: center;">4</td> </tr> <tr> <td></td> <td style="text-align: center;">H Hydrogen 1</td> <td colspan="6"></td> <td style="text-align: center;">He Helium 2</td> </tr> </table>								1	1							4		H Hydrogen 1							He Helium 2																																																																																										
1	1							4																																																																																																												
	H Hydrogen 1							He Helium 2																																																																																																												
2	<table border="1" style="width: 100%; border-collapse: collapse;"> <tr> <td style="text-align: center;">7</td> <td style="text-align: center;">9</td> <td colspan="6"></td> <td style="text-align: center;">20</td> </tr> <tr> <td style="text-align: center;">Li Lithium 3</td> <td style="text-align: center;">Be Beryllium 4</td> <td colspan="6"></td> <td style="text-align: center;">Ne Neon 10</td> </tr> <tr> <td style="text-align: center;">23</td> <td style="text-align: center;">24</td> <td colspan="6"></td> <td style="text-align: center;">35.5</td> </tr> <tr> <td style="text-align: center;">Na Sodium 11</td> <td style="text-align: center;">Mg Magnesium 12</td> <td colspan="6"></td> <td style="text-align: center;">Cl Chlorine 17</td> </tr> <tr> <td style="text-align: center;">39</td> <td style="text-align: center;">40</td> <td colspan="6"></td> <td style="text-align: center;">40</td> </tr> <tr> <td style="text-align: center;">K Potassium 19</td> <td style="text-align: center;">Ca Calcium 20</td> <td colspan="6"></td> <td style="text-align: center;">Ar Argon 18</td> </tr> <tr> <td style="text-align: center;">86</td> <td style="text-align: center;">88</td> <td colspan="6"></td> <td style="text-align: center;">84</td> </tr> <tr> <td style="text-align: center;">Rb Rubidium 37</td> <td style="text-align: center;">Sr Strontium 38</td> <td colspan="6"></td> <td style="text-align: center;">Kr Krypton 36</td> </tr> <tr> <td style="text-align: center;">133</td> <td style="text-align: center;">137</td> <td colspan="6"></td> <td style="text-align: center;">131</td> </tr> <tr> <td style="text-align: center;">Cs Caesium 55</td> <td style="text-align: center;">Ba Barium 56</td> <td colspan="6"></td> <td style="text-align: center;">Xe Xenon 54</td> </tr> <tr> <td style="text-align: center;">223</td> <td style="text-align: center;">226</td> <td colspan="6"></td> <td style="text-align: center;">222</td> </tr> <tr> <td style="text-align: center;">Fr Francium 87</td> <td style="text-align: center;">Ra Radium 88</td> <td colspan="6"></td> <td style="text-align: center;">Rn Radon 86</td> </tr> </table>								7	9							20	Li Lithium 3	Be Beryllium 4							Ne Neon 10	23	24							35.5	Na Sodium 11	Mg Magnesium 12							Cl Chlorine 17	39	40							40	K Potassium 19	Ca Calcium 20							Ar Argon 18	86	88							84	Rb Rubidium 37	Sr Strontium 38							Kr Krypton 36	133	137							131	Cs Caesium 55	Ba Barium 56							Xe Xenon 54	223	226							222	Fr Francium 87	Ra Radium 88							Rn Radon 86
7	9							20																																																																																																												
Li Lithium 3	Be Beryllium 4							Ne Neon 10																																																																																																												
23	24							35.5																																																																																																												
Na Sodium 11	Mg Magnesium 12							Cl Chlorine 17																																																																																																												
39	40							40																																																																																																												
K Potassium 19	Ca Calcium 20							Ar Argon 18																																																																																																												
86	88							84																																																																																																												
Rb Rubidium 37	Sr Strontium 38							Kr Krypton 36																																																																																																												
133	137							131																																																																																																												
Cs Caesium 55	Ba Barium 56							Xe Xenon 54																																																																																																												
223	226							222																																																																																																												
Fr Francium 87	Ra Radium 88							Rn Radon 86																																																																																																												
3	<table border="1" style="width: 100%; border-collapse: collapse;"> <tr> <td style="text-align: center;">27</td> <td style="text-align: center;">28</td> <td style="text-align: center;">31</td> <td style="text-align: center;">32</td> <td colspan="4"></td> <td style="text-align: center;">79</td> <td style="text-align: center;">80</td> </tr> <tr> <td style="text-align: center;">Al Aluminium 13</td> <td style="text-align: center;">Si Silicon 14</td> <td style="text-align: center;">P Phosphorus 15</td> <td style="text-align: center;">S Sulphur 16</td> <td colspan="4"></td> <td style="text-align: center;">Se Selenium 34</td> <td style="text-align: center;">Br Bromine 35</td> </tr> <tr> <td style="text-align: center;">70</td> <td style="text-align: center;">73</td> <td style="text-align: center;">75</td> <td style="text-align: center;">76</td> <td colspan="4"></td> <td style="text-align: center;">128</td> <td style="text-align: center;">127</td> </tr> <tr> <td style="text-align: center;">Ga Gallium 31</td> <td style="text-align: center;">Ge Germanium 32</td> <td style="text-align: center;">As Arsenic 33</td> <td style="text-align: center;">Se Selenium 34</td> <td colspan="4"></td> <td style="text-align: center;">Te Tellurium 52</td> <td style="text-align: center;">I Iodine 53</td> </tr> <tr> <td style="text-align: center;">115</td> <td style="text-align: center;">119</td> <td style="text-align: center;">122</td> <td style="text-align: center;">127</td> <td colspan="4"></td> <td style="text-align: center;">209</td> <td style="text-align: center;">210</td> </tr> <tr> <td style="text-align: center;">In Indium 49</td> <td style="text-align: center;">Sn Tin 50</td> <td style="text-align: center;">Sb Antimony 51</td> <td style="text-align: center;">Te Tellurium 52</td> <td colspan="4"></td> <td style="text-align: center;">Bi Bismuth 83</td> <td style="text-align: center;">Po Polonium 84</td> </tr> <tr> <td style="text-align: center;">204</td> <td style="text-align: center;">207</td> <td style="text-align: center;">209</td> <td style="text-align: center;">210</td> <td colspan="4"></td> <td style="text-align: center;">210</td> <td style="text-align: center;">210</td> </tr> <tr> <td style="text-align: center;">Tl Thallium 81</td> <td style="text-align: center;">Pb Lead 82</td> <td style="text-align: center;">Bi Bismuth 83</td> <td style="text-align: center;">Po Polonium 84</td> <td colspan="4"></td> <td style="text-align: center;">At Astatine 85</td> <td style="text-align: center;">Rn Radon 86</td> </tr> </table>								27	28	31	32					79	80	Al Aluminium 13	Si Silicon 14	P Phosphorus 15	S Sulphur 16					Se Selenium 34	Br Bromine 35	70	73	75	76					128	127	Ga Gallium 31	Ge Germanium 32	As Arsenic 33	Se Selenium 34					Te Tellurium 52	I Iodine 53	115	119	122	127					209	210	In Indium 49	Sn Tin 50	Sb Antimony 51	Te Tellurium 52					Bi Bismuth 83	Po Polonium 84	204	207	209	210					210	210	Tl Thallium 81	Pb Lead 82	Bi Bismuth 83	Po Polonium 84					At Astatine 85	Rn Radon 86																												
27	28	31	32					79	80																																																																																																											
Al Aluminium 13	Si Silicon 14	P Phosphorus 15	S Sulphur 16					Se Selenium 34	Br Bromine 35																																																																																																											
70	73	75	76					128	127																																																																																																											
Ga Gallium 31	Ge Germanium 32	As Arsenic 33	Se Selenium 34					Te Tellurium 52	I Iodine 53																																																																																																											
115	119	122	127					209	210																																																																																																											
In Indium 49	Sn Tin 50	Sb Antimony 51	Te Tellurium 52					Bi Bismuth 83	Po Polonium 84																																																																																																											
204	207	209	210					210	210																																																																																																											
Tl Thallium 81	Pb Lead 82	Bi Bismuth 83	Po Polonium 84					At Astatine 85	Rn Radon 86																																																																																																											
4	<table border="1" style="width: 100%; border-collapse: collapse;"> <tr> <td colspan="2"></td> <td style="text-align: center;">59</td> <td style="text-align: center;">59</td> <td style="text-align: center;">56</td> <td style="text-align: center;">55</td> <td colspan="2"></td> <td style="text-align: center;">63.5</td> <td style="text-align: center;">65</td> </tr> <tr> <td colspan="2"></td> <td style="text-align: center;">Co Cobalt 27</td> <td style="text-align: center;">Ni Nickel 28</td> <td style="text-align: center;">Cu Copper 29</td> <td style="text-align: center;">Zn Zinc 30</td> <td colspan="2"></td> <td style="text-align: center;">Zn Zinc 30</td> <td style="text-align: center;">Br Bromine 35</td> </tr> <tr> <td colspan="2"></td> <td style="text-align: center;">103</td> <td style="text-align: center;">106</td> <td style="text-align: center;">108</td> <td style="text-align: center;">112</td> <td colspan="2"></td> <td style="text-align: center;">112</td> <td style="text-align: center;">127</td> </tr> <tr> <td colspan="2"></td> <td style="text-align: center;">Rh Rhodium 45</td> <td style="text-align: center;">Pd Palladium 46</td> <td style="text-align: center;">Ag Silver 47</td> <td style="text-align: center;">Cd Cadmium 48</td> <td colspan="2"></td> <td style="text-align: center;">Cd Cadmium 48</td> <td style="text-align: center;">I Iodine 53</td> </tr> <tr> <td colspan="2"></td> <td style="text-align: center;">192</td> <td style="text-align: center;">195</td> <td style="text-align: center;">197</td> <td style="text-align: center;">201</td> <td colspan="2"></td> <td style="text-align: center;">201</td> <td style="text-align: center;">210</td> </tr> <tr> <td colspan="2"></td> <td style="text-align: center;">Ir Iridium 77</td> <td style="text-align: center;">Pt Platinum 78</td> <td style="text-align: center;">Au Gold 79</td> <td style="text-align: center;">Hg Mercury 80</td> <td colspan="2"></td> <td style="text-align: center;">Hg Mercury 80</td> <td style="text-align: center;">At Astatine 85</td> </tr> </table>										59	59	56	55			63.5	65			Co Cobalt 27	Ni Nickel 28	Cu Copper 29	Zn Zinc 30			Zn Zinc 30	Br Bromine 35			103	106	108	112			112	127			Rh Rhodium 45	Pd Palladium 46	Ag Silver 47	Cd Cadmium 48			Cd Cadmium 48	I Iodine 53			192	195	197	201			201	210			Ir Iridium 77	Pt Platinum 78	Au Gold 79	Hg Mercury 80			Hg Mercury 80	At Astatine 85																																																
		59	59	56	55			63.5	65																																																																																																											
		Co Cobalt 27	Ni Nickel 28	Cu Copper 29	Zn Zinc 30			Zn Zinc 30	Br Bromine 35																																																																																																											
		103	106	108	112			112	127																																																																																																											
		Rh Rhodium 45	Pd Palladium 46	Ag Silver 47	Cd Cadmium 48			Cd Cadmium 48	I Iodine 53																																																																																																											
		192	195	197	201			201	210																																																																																																											
		Ir Iridium 77	Pt Platinum 78	Au Gold 79	Hg Mercury 80			Hg Mercury 80	At Astatine 85																																																																																																											
5	<table border="1" style="width: 100%; border-collapse: collapse;"> <tr> <td colspan="2"></td> <td style="text-align: center;">48</td> <td style="text-align: center;">51</td> <td style="text-align: center;">52</td> <td style="text-align: center;">55</td> <td colspan="2"></td> <td style="text-align: center;">56</td> <td style="text-align: center;">59</td> </tr> <tr> <td colspan="2"></td> <td style="text-align: center;">Ti Titanium 22</td> <td style="text-align: center;">V Vanadium 23</td> <td style="text-align: center;">Cr Chromium 24</td> <td style="text-align: center;">Mn Manganese 25</td> <td colspan="2"></td> <td style="text-align: center;">Fe Iron 26</td> <td style="text-align: center;">Co Cobalt 27</td> </tr> <tr> <td colspan="2"></td> <td style="text-align: center;">91</td> <td style="text-align: center;">93</td> <td style="text-align: center;">96</td> <td style="text-align: center;">99</td> <td colspan="2"></td> <td style="text-align: center;">101</td> <td style="text-align: center;">103</td> </tr> <tr> <td colspan="2"></td> <td style="text-align: center;">Zr Zirconium 40</td> <td style="text-align: center;">Nb Niobium 41</td> <td style="text-align: center;">Mo Molybdenum 42</td> <td style="text-align: center;">Tc Technetium 43</td> <td colspan="2"></td> <td style="text-align: center;">Ru Ruthenium 44</td> <td style="text-align: center;">Rh Rhodium 45</td> </tr> <tr> <td colspan="2"></td> <td style="text-align: center;">179</td> <td style="text-align: center;">181</td> <td style="text-align: center;">184</td> <td style="text-align: center;">186</td> <td colspan="2"></td> <td style="text-align: center;">190</td> <td style="text-align: center;">192</td> </tr> <tr> <td colspan="2"></td> <td style="text-align: center;">Hf Hafnium 72</td> <td style="text-align: center;">Ta Tantalum 73</td> <td style="text-align: center;">W Tungsten 74</td> <td style="text-align: center;">Re Rhenium 75</td> <td colspan="2"></td> <td style="text-align: center;">Os Osmium 76</td> <td style="text-align: center;">Ir Iridium 77</td> </tr> </table>										48	51	52	55			56	59			Ti Titanium 22	V Vanadium 23	Cr Chromium 24	Mn Manganese 25			Fe Iron 26	Co Cobalt 27			91	93	96	99			101	103			Zr Zirconium 40	Nb Niobium 41	Mo Molybdenum 42	Tc Technetium 43			Ru Ruthenium 44	Rh Rhodium 45			179	181	184	186			190	192			Hf Hafnium 72	Ta Tantalum 73	W Tungsten 74	Re Rhenium 75			Os Osmium 76	Ir Iridium 77																																																
		48	51	52	55			56	59																																																																																																											
		Ti Titanium 22	V Vanadium 23	Cr Chromium 24	Mn Manganese 25			Fe Iron 26	Co Cobalt 27																																																																																																											
		91	93	96	99			101	103																																																																																																											
		Zr Zirconium 40	Nb Niobium 41	Mo Molybdenum 42	Tc Technetium 43			Ru Ruthenium 44	Rh Rhodium 45																																																																																																											
		179	181	184	186			190	192																																																																																																											
		Hf Hafnium 72	Ta Tantalum 73	W Tungsten 74	Re Rhenium 75			Os Osmium 76	Ir Iridium 77																																																																																																											
6	<table border="1" style="width: 100%; border-collapse: collapse;"> <tr> <td colspan="2"></td> <td style="text-align: center;">45</td> <td style="text-align: center;">89</td> <td colspan="2"></td> <td colspan="2"></td> <td style="text-align: center;">139</td> <td style="text-align: center;">184</td> </tr> <tr> <td colspan="2"></td> <td style="text-align: center;">Sc Scandium 21</td> <td style="text-align: center;">Y Yttrium 39</td> <td colspan="2"></td> <td colspan="2"></td> <td style="text-align: center;">La Lanthanum 57</td> <td style="text-align: center;">Ta Tantalum 73</td> </tr> <tr> <td colspan="2"></td> <td style="text-align: center;">137</td> <td style="text-align: center;">139</td> <td colspan="2"></td> <td colspan="2"></td> <td style="text-align: center;">186</td> <td style="text-align: center;">190</td> </tr> <tr> <td colspan="2"></td> <td style="text-align: center;">Ba Barium 56</td> <td style="text-align: center;">La Lanthanum 57</td> <td colspan="2"></td> <td colspan="2"></td> <td style="text-align: center;">Re Rhenium 75</td> <td style="text-align: center;">Os Osmium 76</td> </tr> <tr> <td colspan="2"></td> <td style="text-align: center;">226</td> <td style="text-align: center;">227</td> <td colspan="2"></td> <td colspan="2"></td> <td style="text-align: center;">227</td> <td style="text-align: center;">227</td> </tr> <tr> <td colspan="2"></td> <td style="text-align: center;">Ra Radium 88</td> <td style="text-align: center;">Ac Actinium 89</td> <td colspan="2"></td> <td colspan="2"></td> <td style="text-align: center;">Fr Francium 87</td> <td style="text-align: center;">Rn Radon 86</td> </tr> </table>										45	89					139	184			Sc Scandium 21	Y Yttrium 39					La Lanthanum 57	Ta Tantalum 73			137	139					186	190			Ba Barium 56	La Lanthanum 57					Re Rhenium 75	Os Osmium 76			226	227					227	227			Ra Radium 88	Ac Actinium 89					Fr Francium 87	Rn Radon 86																																																
		45	89					139	184																																																																																																											
		Sc Scandium 21	Y Yttrium 39					La Lanthanum 57	Ta Tantalum 73																																																																																																											
		137	139					186	190																																																																																																											
		Ba Barium 56	La Lanthanum 57					Re Rhenium 75	Os Osmium 76																																																																																																											
		226	227					227	227																																																																																																											
		Ra Radium 88	Ac Actinium 89					Fr Francium 87	Rn Radon 86																																																																																																											
7	<table border="1" style="width: 100%; border-collapse: collapse;"> <tr> <td colspan="2"></td> <td style="text-align: center;">223</td> <td style="text-align: center;">226</td> <td colspan="2"></td> <td colspan="2"></td> <td style="text-align: center;">227</td> <td style="text-align: center;">227</td> </tr> <tr> <td colspan="2"></td> <td style="text-align: center;">Fr Francium 87</td> <td style="text-align: center;">Ra Radium 88</td> <td colspan="2"></td> <td colspan="2"></td> <td style="text-align: center;">Fr Francium 87</td> <td style="text-align: center;">Rn Radon 86</td> </tr> </table>										223	226					227	227			Fr Francium 87	Ra Radium 88					Fr Francium 87	Rn Radon 86																																																																																								
		223	226					227	227																																																																																																											
		Fr Francium 87	Ra Radium 88					Fr Francium 87	Rn Radon 86																																																																																																											

Key

Relative atomic mass
Symbol
Name
Atomic number



SECTION A

Leave
blank

1. Look at the Periodic Table on page 2.

(a) How many elements are there in Period 2?

..... (1)

(b) How many noble gases are there?

..... (1)

(c) Give the symbol of the element whose atoms each contain 14 protons.

..... (1)

(d) Give the symbol of the element that has a relative atomic mass of 14.

..... (1)

(e) Which group contains elements that form ions with a 2- charge?

..... (1)

(Total 5 marks)

Q1



H 2 9 1 8 0 A 0 3 1 6

Leave
blank

2. Use words from the box to complete the sentences.

Each word may be used once, more than once or not at all.

allotropes	carbon	compounds	electrons
elements	hydrogen	neutrons	protons

- (a) Atoms of the same element always contain the same number of
..... (1)
- (b) Isotopes are atoms of the same element which contain different numbers of
..... (1)
- (c) Substances containing only one type of atom are (1)
- (d) Substances whose molecules contain more than one element are
..... (1)
- (e) The negatively-charged particles in an atom are (1)
- (f) In the definition of relative atomic mass, the mass of an atom is compared to the mass
of an atom of (1)

(Total 6 marks)

Q2



Leave
blank

3. The Group 1 elements all react with water to form hydrogen and an alkaline solution. In the following equation, the letter **M** represents one of the Group 1 elements.

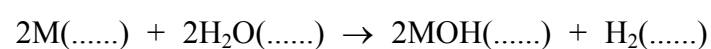

- (a) Complete the equation using the correct state symbols (aq, g, l, s).
Each state symbol may be used once, more than once or not at all. (2)

- (b) Describe **two** observations you would make when a small piece of sodium is added to a trough of water.

1

.....

2

.....

(2)

- (c) Describe a test to show that the solution formed is alkaline.

Test

Result

(2)

Q3

(Total 6 marks)



Leave
blank

4. A student left a piece of iron in the open air for one week. At the end of the week he noticed a colour change which showed that rust had formed on the iron.

(a) What colour shows that rust had formed?

.....
(1)

(b) Name the **two** substances needed for iron to rust.

1

2

(2)

(c) What is the chemical name of rust?

.....
(1)

(d) What type of reaction does the iron undergo when it rusts?

Put a cross (☒) in the correct box.

combustion

decomposition

oxidation

reduction

(1)

(e) Rust does not form on iron that is coated with zinc. Name this method of rust prevention.

.....
(1)

(f) State **one** other way to prevent iron from rusting.

.....
(1)

Q4

(Total 7 marks)



Leave
blank

5. A student adds a solution to solid samples of two different sodium compounds.

The equations for the reactions occurring are:



(a) Name the solution she adds to each sample.

..... (1)

(b) Describe **one** observation the student could make in Reaction 1.

.....
..... (1)

(c) Describe a test for the carbon dioxide that forms in Reaction 1.

Test

Result (2)

(d) Sulphur dioxide produced in Reaction 2 contributes to acid rain in the atmosphere.

Describe **two** effects of acid rain on the environment.

1

.....

2

..... (2)

(Total 6 marks)

Q5



6. The alkanes are a homologous series of saturated hydrocarbons.

The displayed formula of the first member of this series is

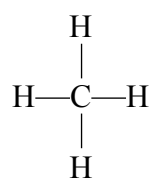

(a) Draw the displayed formula of the second member of this series.

(1)

(b) Give the molecular formula of the alkane with three carbon atoms.

..... (1)

(c) Draw a ring round the general formula for alkanes.

C_nH_{n+3} $\text{C}_n\text{H}_{2n+2}$ C_nH_{3n} C_nH_{4n} (1)

(d) Write a word equation for the complete combustion of butane.

..... (2)

Q6

(Total 5 marks)



BLANK PAGE



7. The diagram shows a blast furnace used to extract iron from its ore. The name of one of the raw materials is shown.

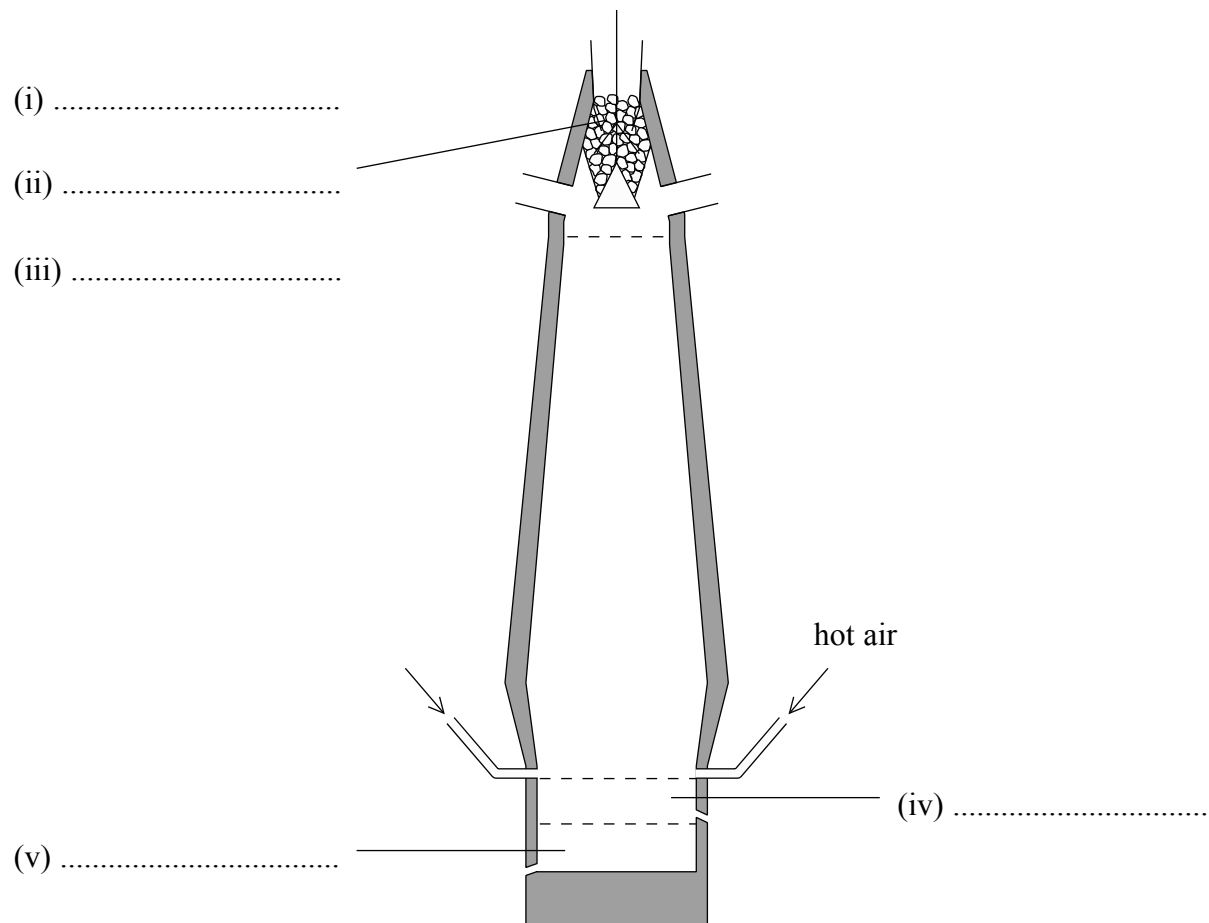

(a) Complete the labelling of the diagram using the names or formulae of the substances.

(5)



Leave
blank

(b) The word equations for two reactions occurring in the blast furnace are:

Reaction 1 carbon + oxygen → carbon dioxide

Reaction 2 carbon dioxide + carbon → carbon monoxide

(i) Which of these reactions (**1** or **2**) produces a high temperature in the blast furnace?

.....
(1)

(ii) State, with a reason, which substance in Reaction **2** undergoes reduction.

Substance

Reason

.....
(2)

(c) Why is it important that carbon monoxide is **not** released into the atmosphere?

.....
.....
(1)

(d) Why is aluminium not extracted from its ore using a blast furnace?

.....
.....
(1)

Q7

(Total 10 marks)

TOTAL FOR SECTION A: 45 MARKS



SECTION B

8. These are the structures of six hydrocarbons.

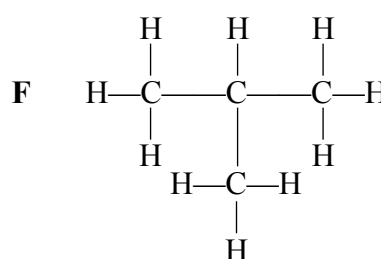
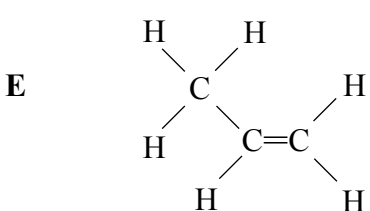
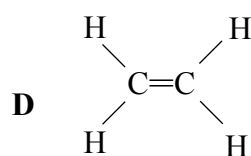
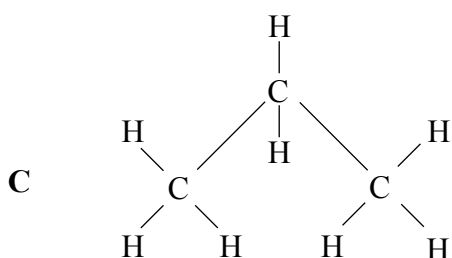
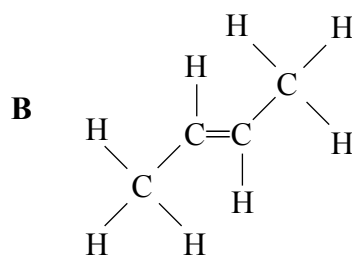
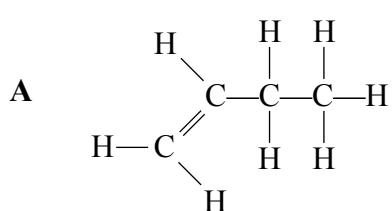

(a) Use the letters of the hydrocarbons to answer these questions.

(i) Give the letter of a hydrocarbon which is **not** an alkene. (1)

(ii) Which structure is propene? (1)

(b) Hydrocarbon **D** forms a polymer. Draw a diagram to represent the structure of the polymer.

Structure of polymer

(2)

Q8

(Total 4 marks)



9. (a) Atoms contain smaller particles. Complete the table to show the relative mass and relative charge of each particle.

Particle	Relative mass	Relative charge
electron		
neutron	1	
proton		+1

(4)

(b) Use the Periodic Table on page 2 to name an element whose atoms

(i) contain equal numbers of protons and neutrons (1)

(ii) have the electronic configuration 2.8.4 (1)

(iii) have no neutrons. (1)

(c) Scientists think they will soon make an element that will go directly below astatine in the Periodic Table. Suggest how many electrons an atom of this element would have in its outer electron shell.

..... (1)

(d) The diagrams show the electronic configuration of helium and of neon.

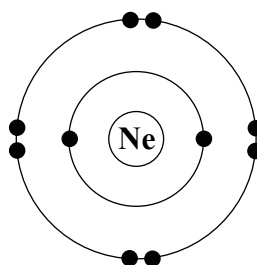
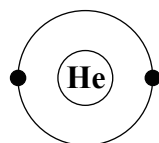

(i) What is the similarity in the outer electron shells of these two atoms?
..... (1)

(ii) What effect does this similarity have on the chemical reactivity of helium and neon?
..... (1)

(Total 10 marks)

Q9



10. Use information from the table to answer this question.

 increasing reactivity	Name of metal	Colour of solid metal	Colour of a solution of the metal(II) sulphate
	magnesium	grey	colourless
	zinc	grey	colourless
	iron	dark grey	green
	copper	pink-brown	blue

(a) When zinc is added to magnesium sulphate solution, no reaction occurs. Explain why.

.....

 (1)

(b) When iron filings are added to copper(II) sulphate solution, a reaction takes place.

(i) Write a chemical equation for this reaction.

.....
 (2)

(ii) Describe the colour changes during this reaction.

Colour change of solid

.....

Colour change of solution

.....
 (4)

(c) When copper is added to dilute sulphuric acid, no reaction occurs. When iron is added to dilute sulphuric acid, hydrogen gas and iron(II) sulphate solution are formed. What does this show about the reactivity of hydrogen compared to the reactivity of copper and the reactivity of iron?

.....

 (2)

(Total 9 marks)

Q10



11. Hydrogen chloride, HCl, is a covalent compound. It is a colourless gas and is soluble in a number of solvents.

(a) (i) Draw a dot and cross diagram to show the covalent bonding in a molecule of hydrogen chloride. Show outer shell electrons only.

(2)

(ii) Hydrogen chloride has a low boiling point. Put a cross (☒) in the correct box to show the reason for this.

The covalent bonds are strong

The covalent bonds are weak

There are weak forces between the ions

There are weak forces between the molecules

(1)

(b) Chlorine exists as two isotopes. Why do these isotopes have identical chemical properties?

..... (1)

(c) Iron forms two chlorides, iron(II) chloride and iron(III) chloride. Describe a chemical test that you could use to distinguish between these compounds.

Test

.....

Result with iron(II) chloride

Result with iron(III) chloride

(3)

Q11

(Total 7 marks)

TOTAL FOR SECTION B: 30 MARKS

TOTAL FOR PAPER: 75 MARKS

END



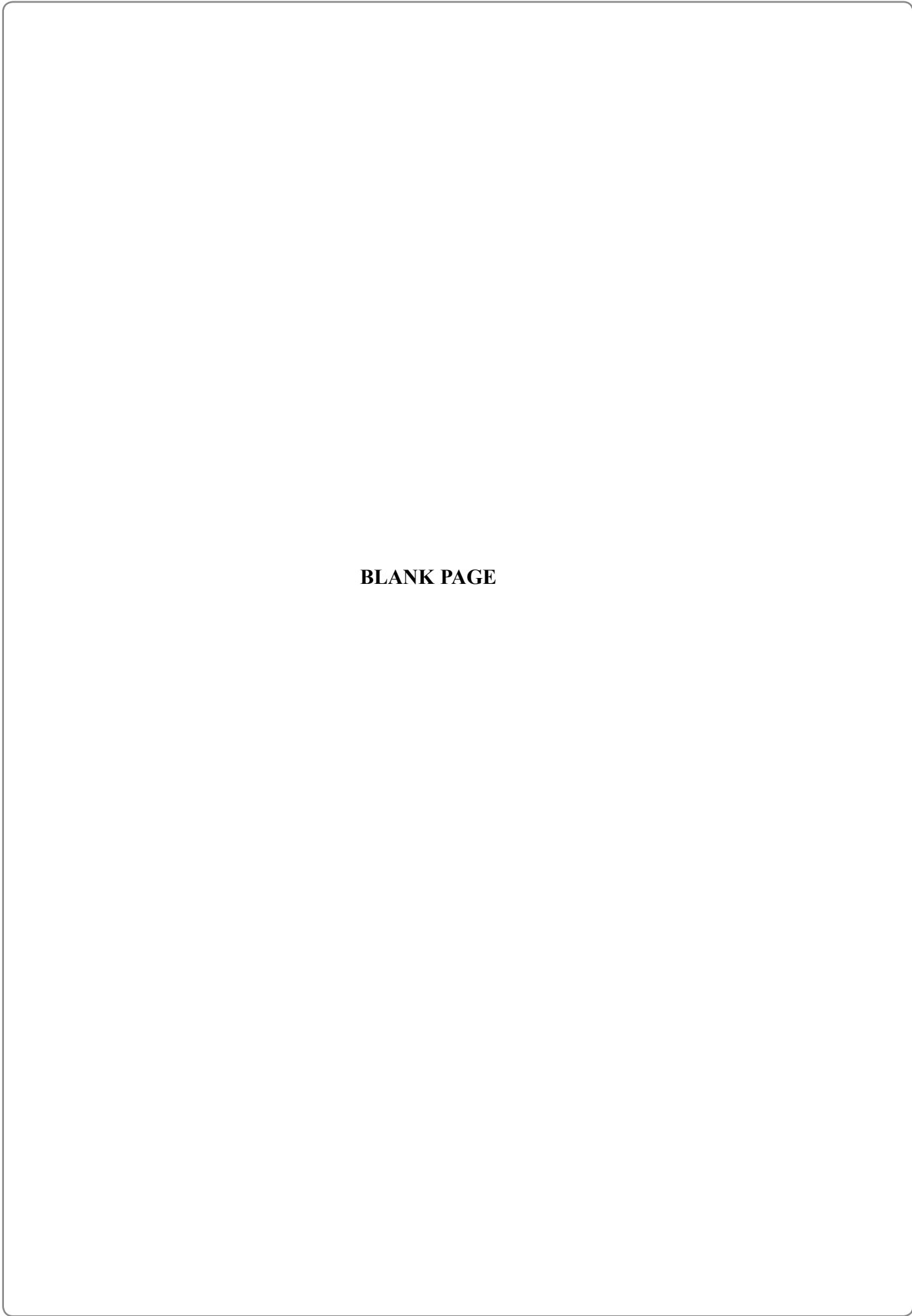

BLANK PAGE

