

Core 1

A dish of hot food is put on a wooden table.

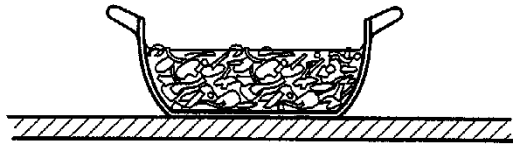

Fig. 1

(a) State three processes by which the dish and its contents could lose heat to the surroundings.

1.
2.
3.[3]

(b) (i) Describe one way of reducing the heat loss to the surroundings.

.....
.....

(ii) Which form of heat loss would this reduce?

.....[2]
.....

Core 2

Here are some statements about energy. Complete the statements using words from the following list.

**chemical, electrical, geothermal, heat, hydroelectric, light,
movement (kinetic), position (potential), strain, tidal, wave**

- (a) A coal fire converts energy into
..... energy and energy. [3]
- (b) When a ball falls from rest, its energy increases
and its energy decreases. [2]
- (c) The source of energy, in which hot rocks under the Earth's surface heat water
to produce steam, is referred to as energy. [1]

Core 3

Fig. 2 shows an electric kettle.

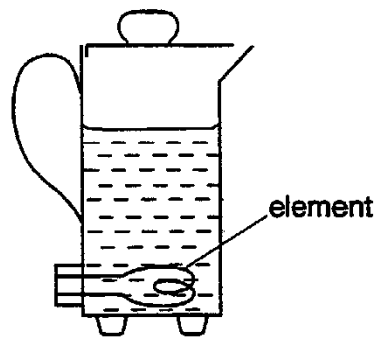

Fig. 2

Explain why the heating element is placed near the bottom of the kettle.

.....

.....

..... [2]

Alternative to Practical 1

A small mass of ammonium chloride is dissolved in some water, causing the temperature of the water to fall. The apparatus, which is used to determine the fall in temperature, is shown in Fig. 3 .

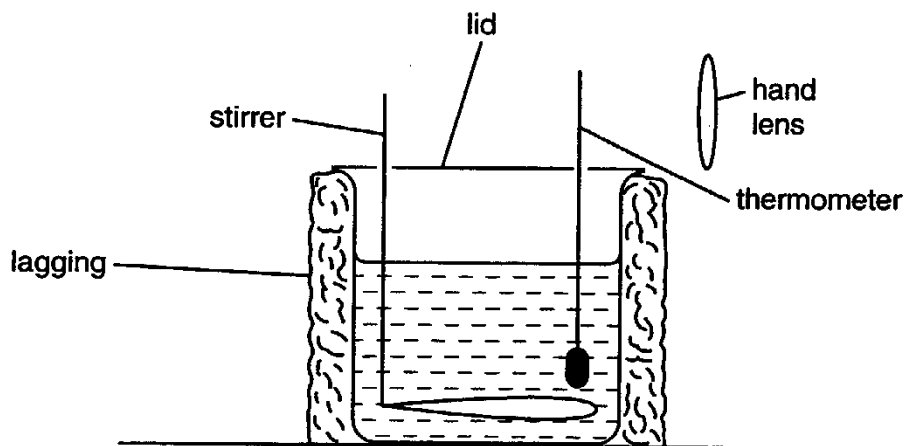

Fig. 3

(a) Give a reason for using each of the following items of apparatus.

(i) the lagging

.....
.....

(ii) the stirrer

.....
.....

(iii) the hand lens

.....
.....

[3]

Alternative to Practical 1

(b) Part of the thermometer that is used to determine the fall in temperature is shown in Fig. 4 . The diagram shows the thermometer before and after adding the ammonium chloride.

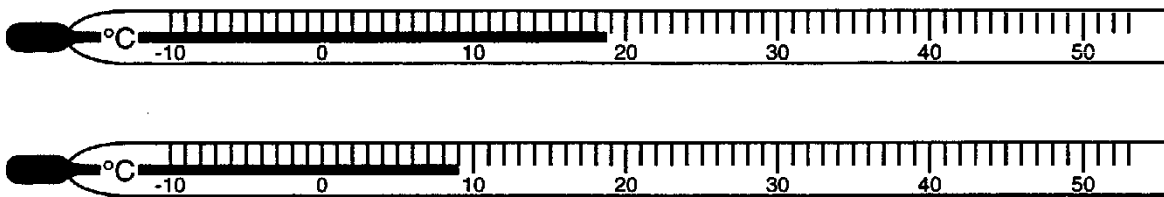

Fig. 4

(i) Record each of the temperatures and determine the fall in temperature.

temperature before adding the ammonium chloride =

temperature after adding the ammonium chloride =

fall in temperature =

(ii) In Fig. 4 the liquid thread is shown along the edge of the scale marks. This is the recommended way to position the liquid thread before reading a temperature. In Fig. 5 the thread is positioned away from the edge of the scale.



Fig. 5

Suggest a reason for the recommended way to use a thermometer.

.....
.....

[4]

(c) How would you avoid making a parallax error when reading the thermometer shown in Fig. 5 ? You may draw a labelled diagram if you wish.

Extension 1

Fig. 6 shows the outline of a machine for driving steel pillars (called piles) into the ground.

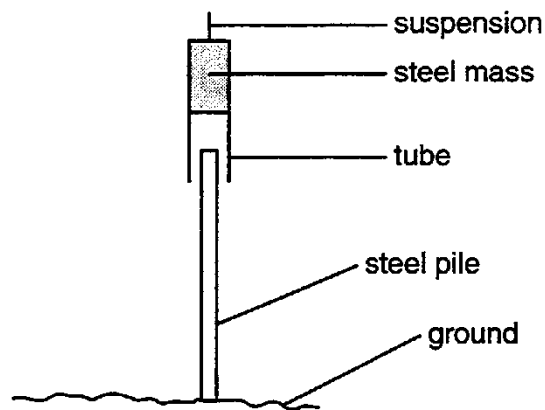

Fig. 6

The steel mass is raised by an electric motor and then falls under gravity. The falling steel has a mass of 200 kg and falls a distance of 6.0 m.

(a) The acceleration of free fall is 10 m/s^2 . Calculate

(i) the potential energy gained by the mass each time it is raised,

potential energy gained =

(ii) the maximum speed at which the mass hits the pile.

speed =

171

Extension 1

(b) When the mass hits the pile, it has kinetic energy. This energy is transformed into other forms of energy as the speed of the falling mass rapidly reduces to zero. As this happens, the pile is forced a small distance into the ground.

(i) State the energy conversions which take place, starting from the kinetic energy of the falling mass.

.....
.....
.....
.....

(ii) Explain how a large force is produced when the pile is driven a short distance into the ground.

.....
.....
.....
.....

[8]

(c) In raising the steel mass 6.0 m, the electric motor uses more energy than that calculated in **(a)(i)**.

Write down and explain **two** causes of this higher energy requirement.

1.
.....
.....
.....

2.
.....
.....
.....

[4]

Extension 1

(d) The equipment design is changed so that when the mass falls once, the pile is driven further into the ground than before the design was changed.

Suggest **three** changes that could be made to do this.

- 1.
.....
 - 2.
.....
 - 3.
.....
-[3]

Core 1

- a any three of
 conduction
 convection
 radiation
 evaporation
- b(i) any suitable procedure
 e.g. a lid
 insulating cover or wrap
- (ii) it would depend on the choice for (i) but from above either evaporation or conduction

Core 2

- a electrical to heat (thermal) and light
- b kinetic (motion)
 potential (position)
- c geothermal

Core 3

Answer should include two of these points.

a description of convection

hot water rises

there can be no convection if it is heated at the top / only the top would be heated in this case

smaller amounts of water can be boiled

Alternative to Practical 1

- a(i) to reduce or prevent conduction of heat / to insulate the can
- (ii) produce a uniform temperature
- (iii) assists in accurate temperature measurement
- b(i) 18.7 or 18.8 °C
8.9 or 9 °C
between 9.7 and 9.9 °C
- (ii) assists accuracy
helps avoiding parallax
helps to be more certain when the thread reaches the scale division
- c take the reading with the line of sight perpendicular to the scale mark

