

**International General Certificate of Secondary Education
CAMBRIDGE INTERNATIONAL EXAMINATIONS**

PHYSICS

PAPER 5 Practical Test

0625/5

MAY/JUNE SESSION 2002

1 hour 15 minutes

Candidates answer on the enclosed Answer Booklet.

Additional materials:

As listed in Instructions to Supervisors

TIME 1 hour 15 minutes

INSTRUCTIONS TO CANDIDATES

Write your name, Centre number and candidate number in the spaces provided on the Answer Booklet.

Answer **all** questions.

Write your answers in the spaces provided in the Answer Booklet.

You are expected to record all your observations as soon as these observations are made. These observations and any arithmetical working of the answers from them should be written in the Answer Booklet; scrap paper should **not** be used.

An account of the method of carrying out the experiments is **not** required but you should record any precautions you take, and it must be clear (by diagrams or otherwise) how the readings were obtained. The theory of the experiments is **not** required.

At the end of examination, hand in only the Answer Booklet.

INFORMATION FOR CANDIDATES

Graph paper is provided in the enclosed Answer Booklet. Additional sheets of graph paper should be used only if it is necessary to do so.

**This question paper consists of 7 printed pages, 1 blank page
and an inserted Answer Booklet.**



- 1 In this experiment, you are to determine the mass of a metre rule.

Record all of your observations and answers on page 3 of the Answer Booklet.

Carry out the following instructions referring to Fig. 1.1.

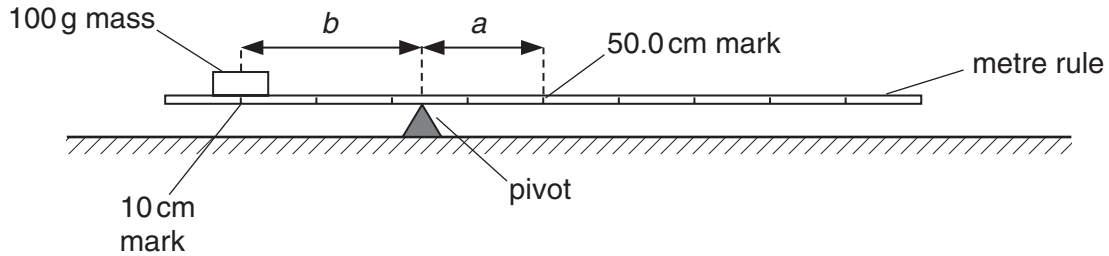

Fig. 1.1

- (a) Place the 100 g mass on the metre rule so that its centre is directly above the 10.0 cm mark.
- (b) Place the rule on the pivot so that the rule is as near as possible to being balanced.
- (c) Measure and record the distance a from the 50.0 cm mark on the rule to the pivot and the distance b from the centre of the 100 g mass to the pivot.
- (d) Calculate the mass M of the metre rule, using the equation

$$M = \frac{kb}{a},$$

where $k = 100 \text{ g}$.

- (e) Explain with the aid of a diagram how you could judge that the centre of the 100 g mass was directly above the 10.0 cm mark.
- (f) Move the 100 g mass to the 20.0 cm mark and repeat steps (b) to (d).
- (g) Calculate and record the average of the two values of M . Show your working.

- 2 In this experiment, you are to investigate the temperature changes when cold water is added to hot water.

Record all of your observations and answers on pages 4 and 5 of the Answer Booklet.

A thermometer is in a beaker of hot water.

Carry out the following instructions referring to Fig. 2.1.

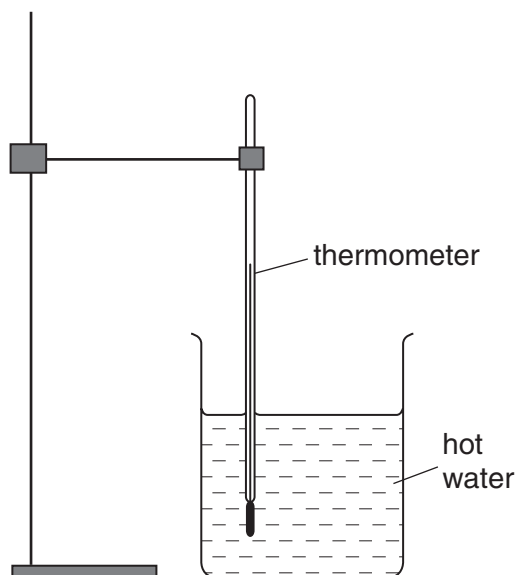

Fig. 2.1

Method 1.

- (a) Measure the temperature of the hot water. This is the temperature at time = 0 s and the volume of cold water added = 0 cm³. Record the temperature in the table.
- (b) As soon as possible after taking this reading, start the stopclock.
- (c) Pour 20 cm³ of cold water into the measuring cylinder. At time 30 s after starting the stopclock, pour this cold water into the beaker of hot water. Record the new water temperature and the volume of cold water added.
- (d) Repeat step (c), adding 20 cm³ of cold water to the beaker at 30 s intervals, up to a total of 150 s, recording the new water temperature and the **total** volume of cold water added from the start.

Method 2.

- (e) Transfer the thermometer to the second beaker of hot water. Reset the stopclock to zero.
- (f) Record the temperature reading for the hot water.
- (g) As soon as possible after taking this reading, start the stopclock.
- (h) Pour 100 cm³ of cold water into the measuring cylinder. At time 150 s after starting the stopclock, pour this cold water into the beaker of hot water. Record the new water temperature.

- (i) Which method, 1 or 2, produces the larger temperature drop in 150 s? Justify your answer by reference to your readings.
- (j) Suggest two modifications you could make to improve the reliability of your conclusion.
- (k) When taking readings from a measuring cylinder, the shape of the meniscus and the position of the eye are two possible sources of error. Show on the diagram on page 5 of the Answer Booklet where the eye should be and from which part of the meniscus the reading is taken.

- 3 In this experiment, you are to determine the focal length of a lens.

Record all of your observations and answers on pages 6 and 7 of the Answer Booklet.

Carry out the following instructions referring to Fig. 3.1.

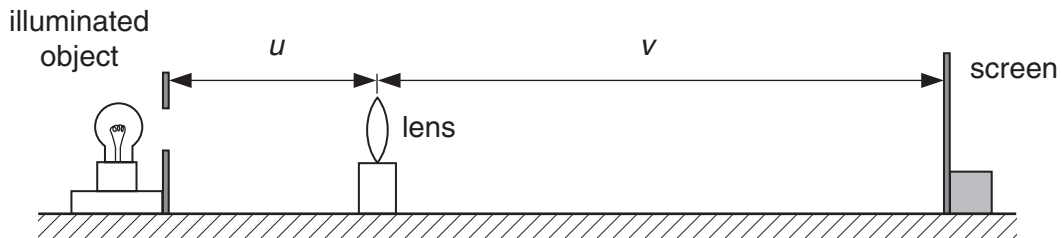

Fig. 3.1

- (a) Place the lens so that its centre is 20.0 cm from the illuminated object.
- (b) Measure and record the distance u in cm from the centre of the lens to the illuminated object, as shown in Fig. 3.1.
- (c) Place the screen close to the lens. Move the screen away from the lens until a focused image of the object is seen on the screen.
- (d) Measure and record the distance v in cm from the centre of the lens to the screen.
- (e) Repeat steps (b) – (d) to find v for each of the values of u below.
- 22.5 cm 25.0 cm 35.0 cm 45.0 cm
- (f) Plot the graph of v/cm (y -axis) against u/cm (x -axis). Draw the best fit curve.
- (g) Mark on the graph the points $v = u = 10.0\text{ cm}$ and $v = u = 40.0\text{ cm}$. Draw the straight line between the points. Record u_0 , the value of u at the point where the curve cuts the straight line. Show clearly on the graph how you obtained this value.
- (h) It can be shown that the focal length of the lens is equal to $u_0/2$. Use the equation $f = u_0/2$ to calculate the focal length.

- 4 In this experiment, you are to measure the potential differences across lamps in a circuit. Record all of your observations and answers on pages 8 and 9 of the Answer Booklet. Carry out the following instructions referring to Fig. 4.1.

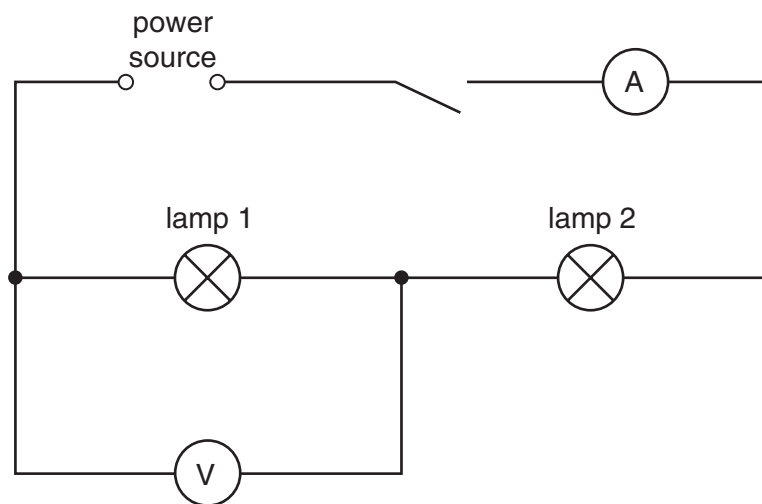

Fig. 4.1

- (a) The circuit shown in Fig. 4.1 is set up for you. Switch on. Record I , the current through the lamps. Record V_1 , the p.d. across lamp 1. Switch off.
- (b) Rearrange the circuit so that the voltmeter is connected in parallel with lamp 2. Switch on. Record V_2 , the p.d. across lamp 2. Switch off.
- (c) Calculate V_1/V_2 .
- (d) The resistance of each lamp can be calculated using the equation $R = V/I$. Calculate R_1 , the resistance of lamp 1, and R_2 , the resistance of lamp 2.
- (e) Calculate R_1/R_2 .
- (f) Within the limits of experimental error, compare the values of V_1/V_2 and R_1/R_2 .
- (g) Fig. 4.2 shows an electrical circuit. Redraw the circuit as a circuit diagram, using standard symbols.

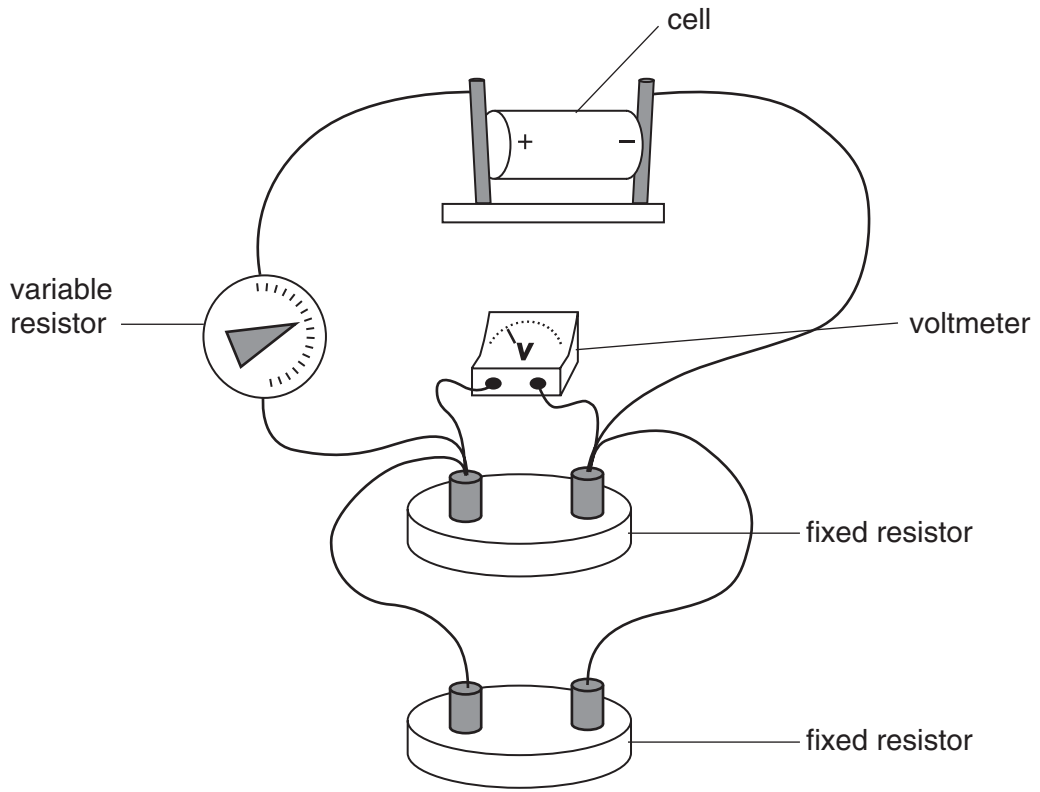

Fig. 4.2

