

International General Certificate of Secondary Education
CAMBRIDGE INTERNATIONAL EXAMINATIONS

PHYSICS
PAPER 1 Multiple Choice

0625/1

MAY/JUNE SESSION 2002
45 minutes

Additional materials:
Multiple Choice answer sheet
Soft clean eraser
Soft pencil (type B or HB is recommended)

TIME 45 minutes

INSTRUCTIONS TO CANDIDATES

Do not open this booklet until you are told to do so.

Write your name, Centre number and candidate number on the answer sheet in the spaces provided unless this has already been done for you.

There are forty questions in this paper. Answer all questions. For each question, there are four possible answers, A, B, C and D. Choose the one you consider correct and record your choice in soft pencil on the separate answer sheet.

Read very carefully the instructions on the answer sheet.

INFORMATION FOR CANDIDATES

Each correct answer will score one mark. A mark will not be deducted for a wrong answer.

Any rough working should be done in this booklet.

This question paper consists of 17 printed pages and 3 blank pages.



- 1 The diagram shows the level of liquid in a measuring cylinder.

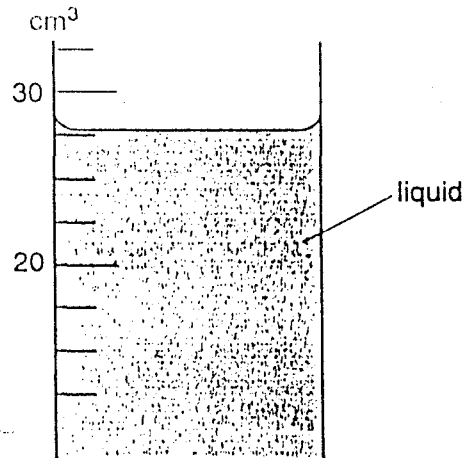

What is the volume of the liquid?

- A 24 cm^3 B 28 cm^3 C 29 cm^3 D 32 cm^3
- 2 A cylindrical can is rolled along the ruler shown in the diagram.

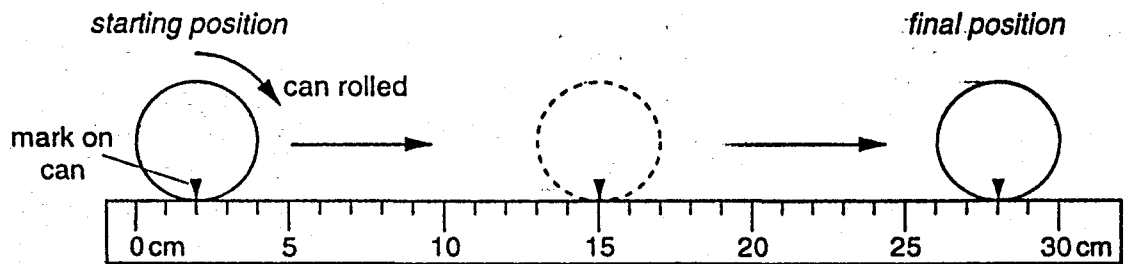

The can rolls over twice.

What is the circumference (distance all round) of the can?

- A 13 cm B 14 cm C 26 cm D 28 cm

- 3 The graph shows how the speed of a car changes with time.

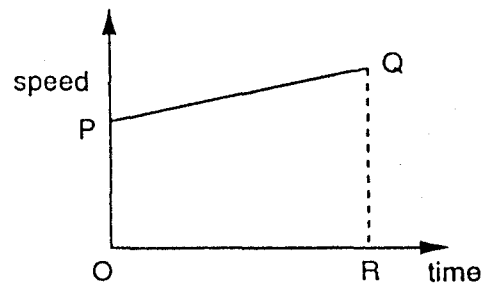

Which of the following gives the distance travelled in time interval OR?

- A the area OPQR
 B the length PQ
 C the length (QR – PO)
 D the ratio QR/PO
- 4 A snail crosses a garden path 30 cm wide at a speed of 0.2 cm/s.

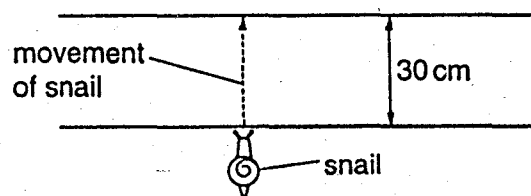

How long does the snail take?

- A 0.0067 s B 6.0 s C 15 s D 150 s
- 5 What are correct units used for mass and for weight?

	mass	weight
A	kg	kg
B	kg	N
C	N	kg
D	N	N

- 6 Two objects X and Y are placed on a beam as shown. The beam balances on a pivot at its centre.

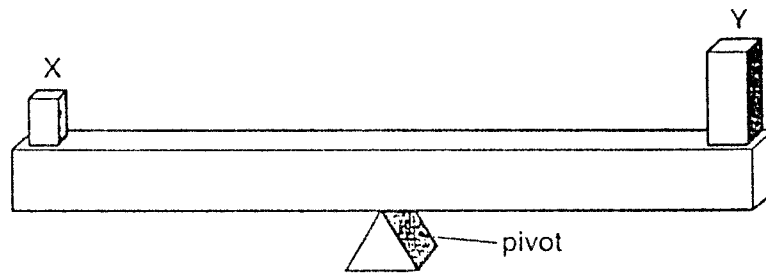

What does this show about X and Y?

- A They have the same mass and the same density.
 - B They have the same mass and the same weight.
 - C They have the same volume and the same density.
 - D They have the same volume and the same weight.
- 7 A shop-keeper places two identical blocks of cheese on a set of scales and notices that their combined mass is 240 g. Each block measures 2.0 cm x 5.0 cm x 10.0 cm.

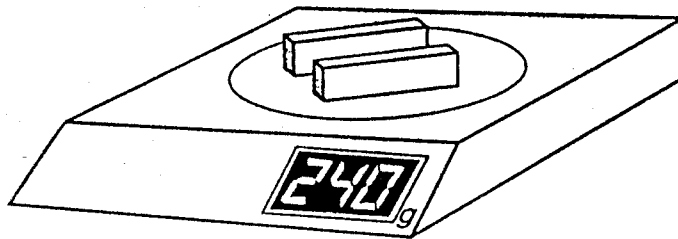

What is the density of the cheese?

- A 0.42 g/cm^3
 - B 0.83 g/cm^3
 - C 1.2 g/cm^3
 - D 2.4 g/cm^3
- 8 The table shows the length of a wire as the load on it is increased.

load/N	0	10	20	30
length/cm	50.0	52.1	54.1	56.3

Which subtraction should be made to find the extension caused by the 20 N load?

- A $54.1 \text{ cm} - 0 \text{ cm}$
- B $54.1 \text{ cm} - 50.0 \text{ cm}$
- C $54.1 \text{ cm} - 52.1 \text{ cm}$
- D $56.3 \text{ cm} - 54.1 \text{ cm}$

- 9 A child tries to push over a large empty oil drum.

Where should the drum be pushed to topple it over with least force?

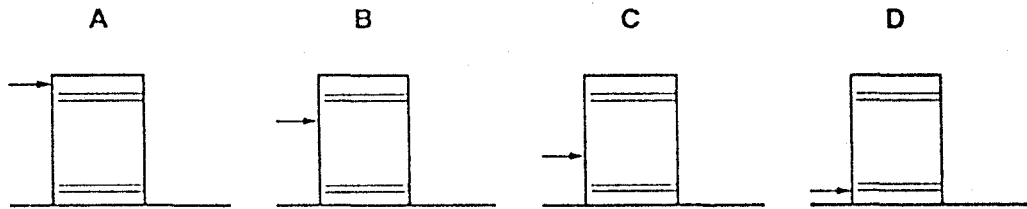

- 10 Which device is designed to convert chemical energy into kinetic energy (energy of motion)?

- A an a.c. generator
- B a battery-powered torch
- C a car engine
- D a wind-up mechanical clock

- 11 A ball is released from rest and rolls down a track from the position shown.

What is the furthest position the ball could reach?

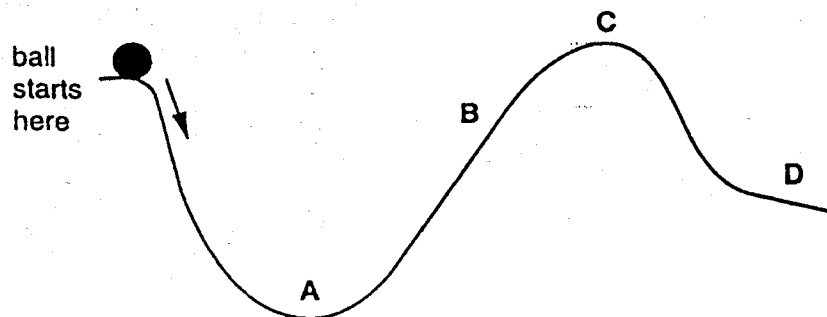

- 12 Two sharp nails and two blunt nails are held on a piece of wood. Each nail is hit with the same hammer with the same amount of force.

When it is hit, which nail causes the greatest pressure on the wood?

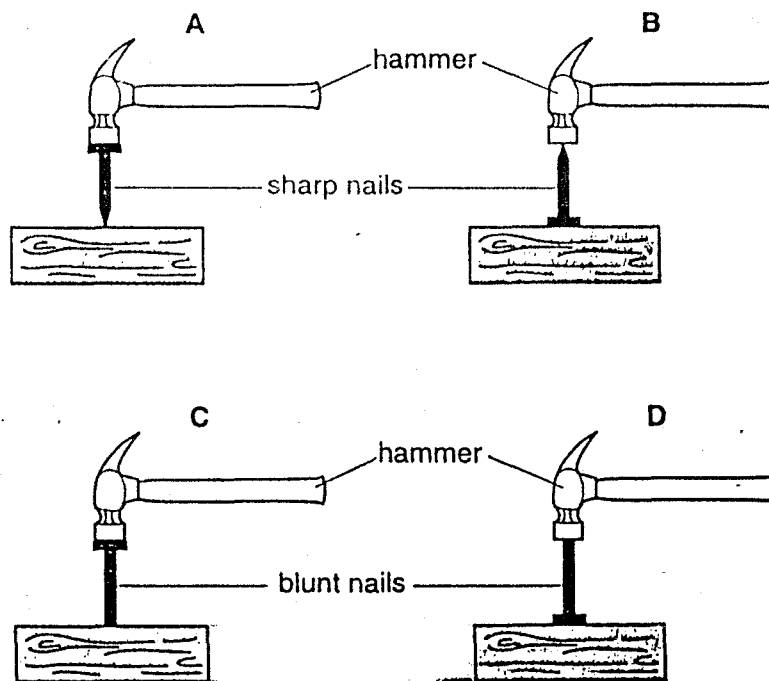

- 13 The diagram shows a manometer connected to a container of carbon dioxide.

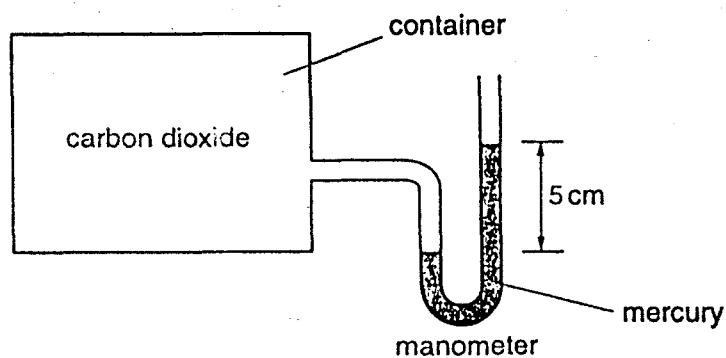

Which statement correctly describes the pressure exerted by the carbon dioxide?

- A It is equal to the atmospheric pressure.
- B It is equal to 5 cm of mercury.
- C It is equal to 5 cm of mercury above atmospheric pressure.
- D It is equal to 5 cm of mercury below atmospheric pressure.

14 The diagram represents molecules in a liquid.

A and C are molecules with a high amount of energy.

B and D are molecules with a low amount of energy.

Which molecule is most likely to be leaving the liquid by evaporation?

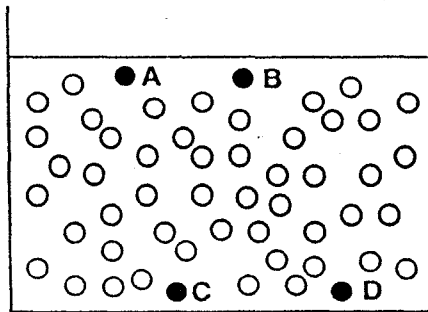

15 The size of a balloon increases when the pressure inside it increases.

The balloon gets bigger when it is left in the heat from the Sun.

cool balloon

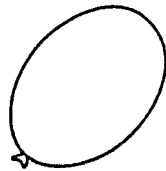

hot balloon

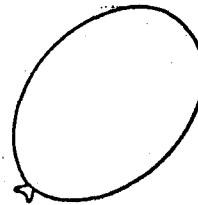

Why does this happen?

- A The air molecules inside the balloon all move outwards when it is heated.
- B The air molecules inside the balloon are bigger when it is heated.
- C The air molecules inside the balloon move more quickly when it is heated.
- D The number of air molecules inside the balloon increases when it is heated.

16 What must expand in order to show the temperature rise in a mercury-in-glass thermometer?

- A the glass bulb
- B the glass stem
- C the mercury
- D the vacuum

17 The table shows the melting points and boiling points of four substances.

Which substance is a liquid at a room temperature of 20 °C?

substance	melting point / °C	boiling point / °C
A	-101	-35
B	-39	357
C	30	2100
D	327	1750

18 A bar made of half wood and half copper has a piece of paper wrapped tightly round it.

The bar is heated strongly at the centre for a short time, and the paper goes brown on one side only.

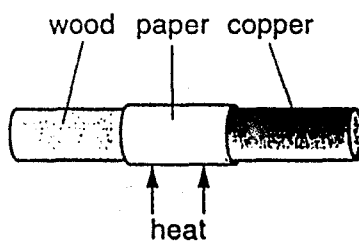

Which side goes brown, and what does this show about wood and copper?

	brown side	wood	copper
A	copper	conductor	insulator
B	copper	insulator	conductor
C	wood	conductor	insulator
D	wood	insulator	conductor

19 The diagrams show part of a water-heating system which is working by convection.

Which diagram shows the most likely flow of water in the system?

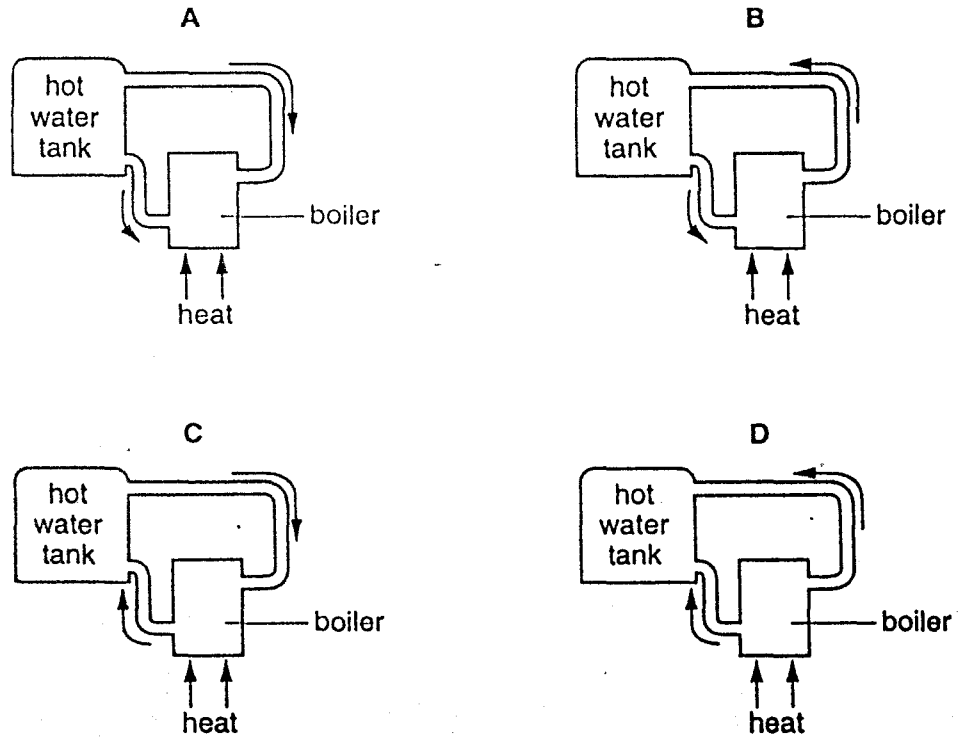

20 A drop of water from a tap falls onto the surface of some water of constant depth.

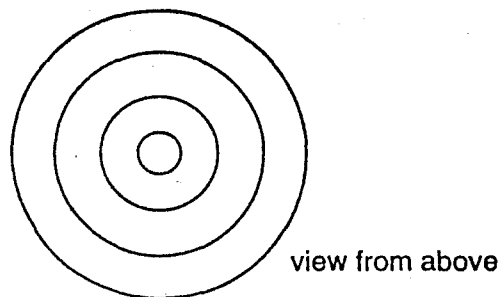

Water waves spread out on the surface of the water.

Which statement is true?

- A The waves are longitudinal and travel at the same speed in all directions.
- B The waves are longitudinal and travel more quickly in one direction than in others.
- C The waves are transverse and travel at the same speed in all directions.
- D The waves are transverse and travel more quickly in one direction than in others.

- 21 A student measures how far a cork moves up and down on a wave in a tank of water.

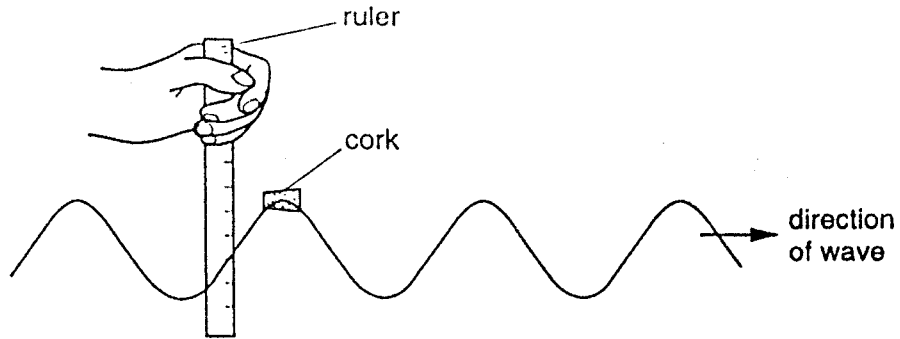

Which quantity can he obtain from his measurement?

- A amplitude
 - B frequency
 - C speed
 - D wavelength
- 22 Alpha-particles, beta-particles, gamma-rays and infra-red radiation may all be emitted from a solid.

Which of these are included in the electromagnetic spectrum?

- A alpha-particles and beta-particles
- B alpha-particles and gamma-rays
- C beta-particles and infra-red radiation
- D gamma-rays and infra-red radiation

- 23 The image of a clock face as seen in a plane mirror is shown.

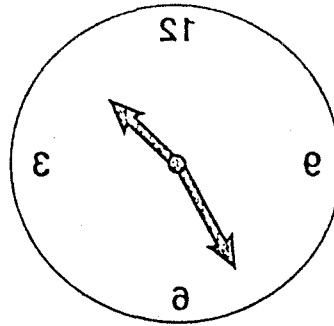

What is the actual time on the clock?

- A 1.25 B 1.35 C 10.25 D 10.35
- 24 Four sound waves W, X, Y and Z are displayed by an oscilloscope screen. The oscilloscope settings are the same in each case.

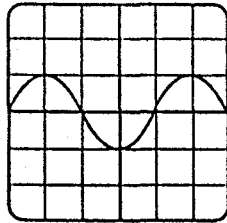

W

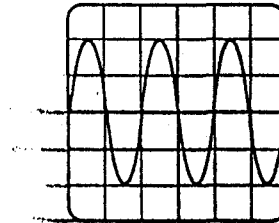

X

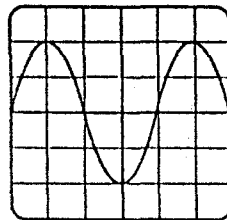

Y

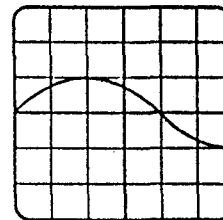

Z

Which two sounds have the same pitch?

- A W and X
 B W and Y
 C X and Y
 D X and Z

- 25 A girl stands in front of a rock face

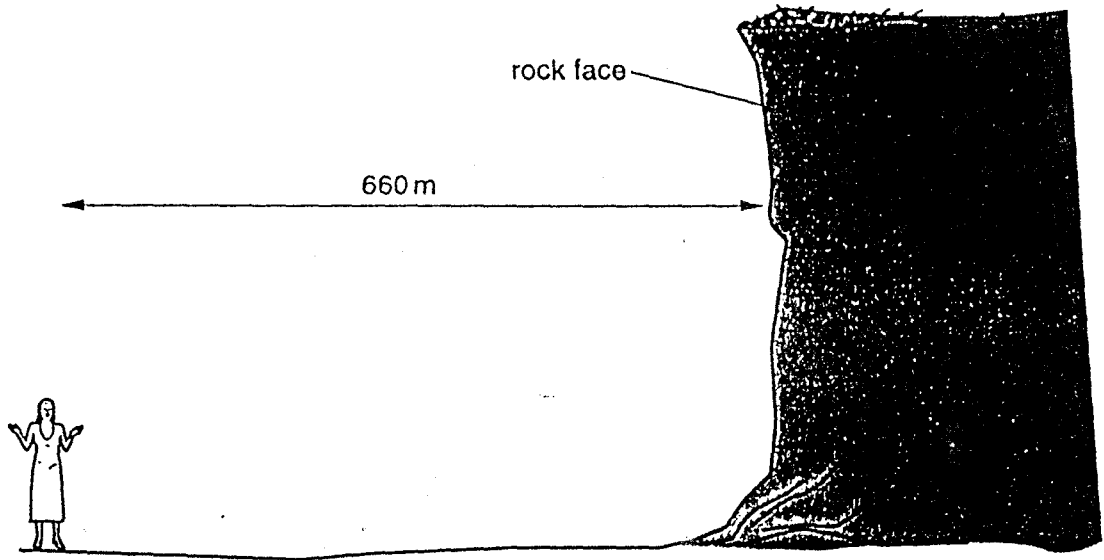

The girl claps her hands once. The speed of sound in air is 330 m/s.

How long is it before she hears the echo?

- A $\frac{2 \times 660}{330}$ s B $\frac{660}{330}$ s C $\frac{330}{660}$ s D $\frac{330}{2 \times 660}$ s

- 26 Which diagram best shows the pattern of field lines around a bar magnet?

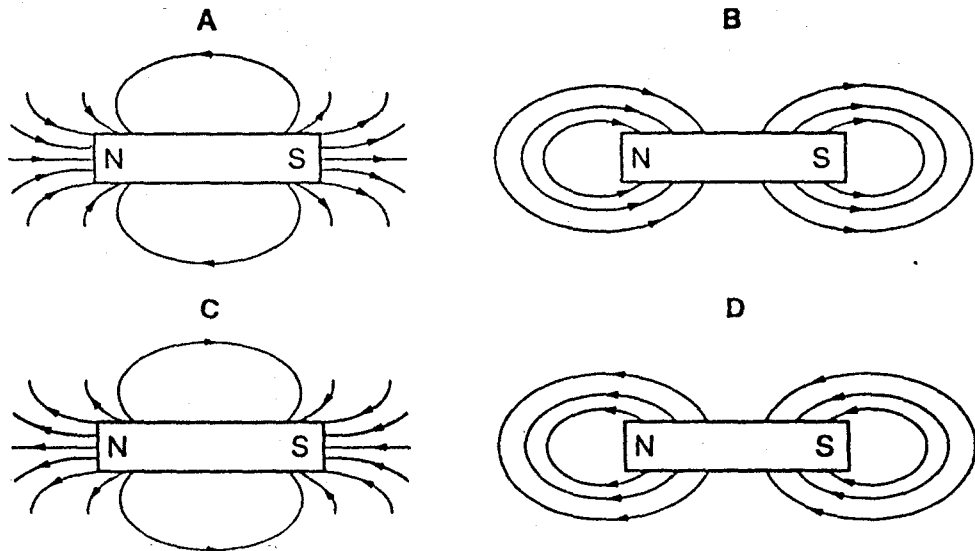

27 Which materials are suitable to make a permanent magnet and the core of an electromagnet?

	permanent magnet	core of an electromagnet
A	iron	iron
B	iron	steel
C	steel	iron
D	steel	steel

28 Which two electrical quantities are measured in volts?

- A current and e.m.f.
- B current and resistance
- C e.m.f. and potential difference
- D potential difference and resistance

29 Which of the following pieces of copper wire has the greatest electrical resistance?

	length/m	diameter/mm
A	5.0	0.05
B	5.0	0.10
C	50	0.05
D	50	0.10

30 A $20\ \Omega$ resistor and a $10\ \Omega$ resistor are connected in parallel.

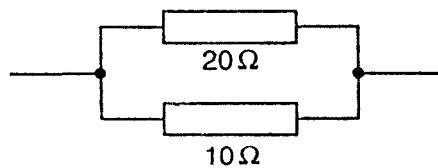

What is their combined resistance?

- A less than $10\ \Omega$
- B $10\ \Omega$
- C $20\ \Omega$
- D more than $20\ \Omega$

- 31 The diagram shows an incomplete circuit.

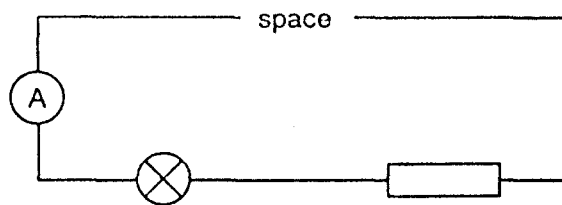

Which component should be connected in the space to make the lamp light?

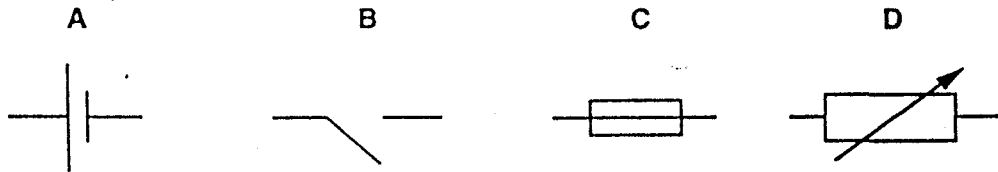

- 32 Why are the electric lamps in a house lighting circuit normally connected in parallel?

- A The current in every circuit must be the same.
- B The lamps are always switched on and off at the same time.
- C The voltage across each lamp must be the mains voltage.
- D When one of the lamps blows, all the others go out.

- 33 In the circuit shown, one of the fuses blows and all the lamps go out.

Which fuse blows?

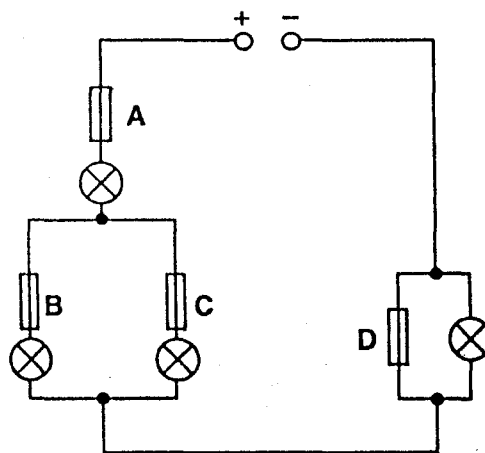

- 34 When electricity is transmitted over long distances, energy is wasted. How can the wasted energy be kept as small as possible?
- A Keep the current in the transmission lines as large as possible.
 - B Keep the power supplied to the transmission lines as large as possible.
 - C Keep the resistance of the transmission lines as large as possible.
 - D Keep the voltage supplied to the transmission lines as large as possible.
- 35 The diagram shows a transformer.

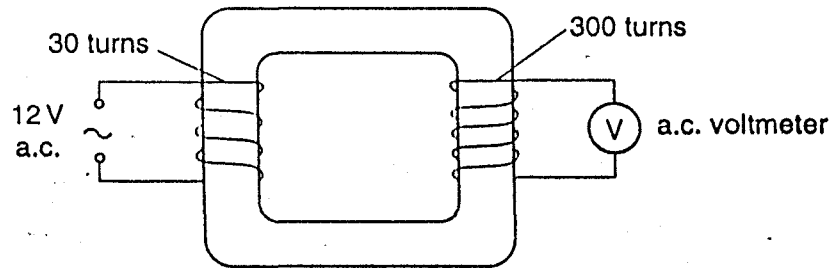

What is the voltmeter reading?

- A 1.2V
- B 12V
- C 120V
- D 1200V

36 The diagram shows part of a circuit used to switch street lamps on and off automatically.

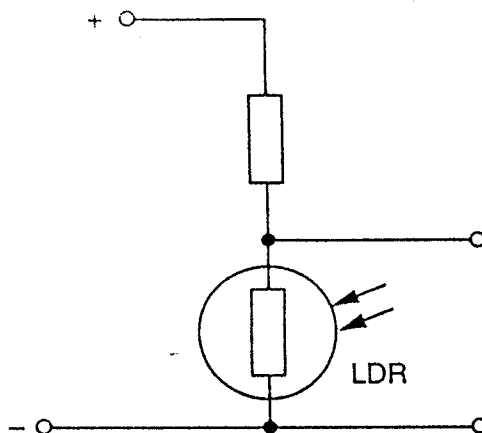

What is the effect on the light-dependent resistor (LDR) when it gets dark?

	resistance of LDR	p.d. across LDR
A	decreases	decreases
B	decreases	increases
C	increases	decreases
D	increases	increases

37 An alternating potential difference (p.d.) is applied to the Y-plates of a cathode-ray oscilloscope. The time-base is turned off.

Which of the following patterns would appear on the screen?

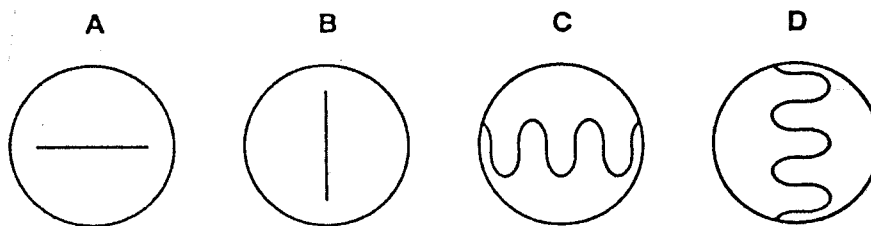

38 What is a beta-particle?

- A** a helium nucleus
- B** a high-energy electron
- C** four protons
- D** two neutrons

39 The diagram shows a radioactivity experiment.

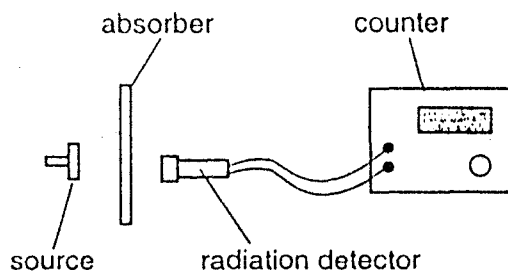

When a piece of paper is used as the absorber, the count rate drops to the background count rate.

What radiation is the source emitting?

- A alpha only
- B beta only
- C gamma only
- D alpha, beta and gamma

40 ${}_{10}^{22}\text{Ne}$ represents an atom of neon.

How many neutrons does it have?

- A 10 B 12 C 22 D 32