

International General Certificate of Secondary Education  
UNIVERSITY OF CAMBRIDGE LOCAL EXAMINATIONS SYNDICATE

**PHYSICS**

**0625/1**

PAPER 1 Multiple Choice

Tuesday

7 NOVEMBER 2000

Morning

45 minutes

Additional materials:

- Electronic calculator and/or Mathematical tables
- Multiple Choice answer sheet
- Soft clean eraser
- Soft pencil (type B or HB is recommended)

**TIME** 45 minutes

**INSTRUCTIONS TO CANDIDATES**

Do not open this booklet until you are told to do so.

Write your name, Centre number and candidate number on the answer sheet in the spaces provided unless this has already been done for you.

There are forty questions in this paper. Answer all questions. For each question, there are four possible answers, A, B, C and D. Choose the one you consider correct and record your choice in soft pencil on the separate answer sheet.

Read very carefully the instructions on the answer sheet.

**INFORMATION FOR CANDIDATES**

Each correct answer will score one mark. A mark will not be deducted for a wrong answer.

Any rough working should be done in this booklet.

A PDF Split DEMO - Purchase from www.A-PDF.com to remove the watermark

---

This question paper consists of 19 printed pages and 1 blank page.

- 1 The diagram shows a measuring cylinder.

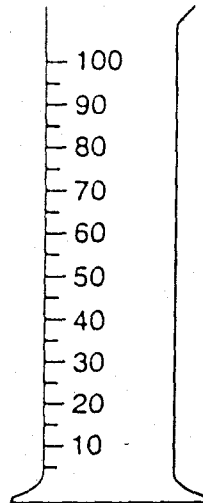

Which unit would be most suitable for its scale?

- A  $\text{mm}^2$     B  $\text{mm}^3$     C  $\text{cm}^2$     D  $\text{cm}^3$
- 2 The diagrams show the times on a stopclock at the start and at the finish of an experiment.

stopclock  
at start

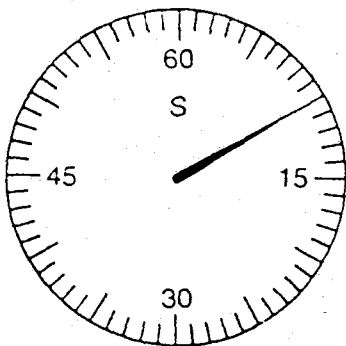

stopclock  
at finish

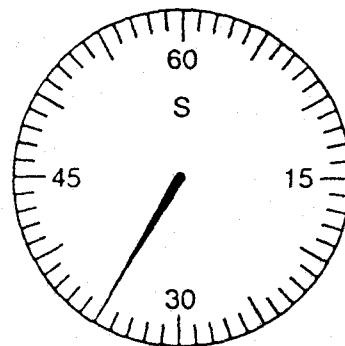

How long did the experiment take?

- A 10 s    B 25 s    C 35 s    D 45 s

- 3 A ball is thrown up into the air. The diagram shows the ball's path.

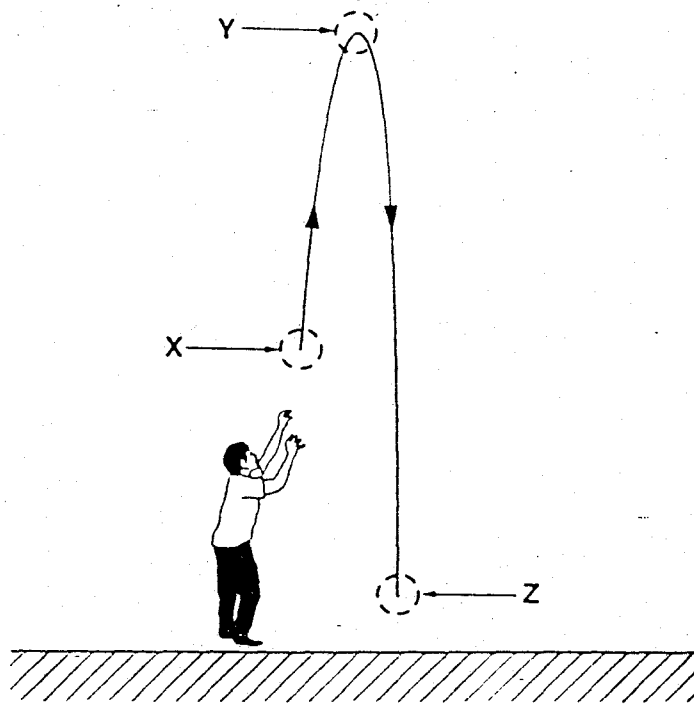

Ignoring air resistance, which statement about the acceleration of the ball is correct?

- A It is least at point X.
  - B It is zero at point Y.
  - C It is greatest at point Z.
  - D It is the same at points X, Y and Z.
- 4 Which graph shows the speed of a stone, dropped from the top of a building, until it hits the ground? (Assume there is no air resistance.)

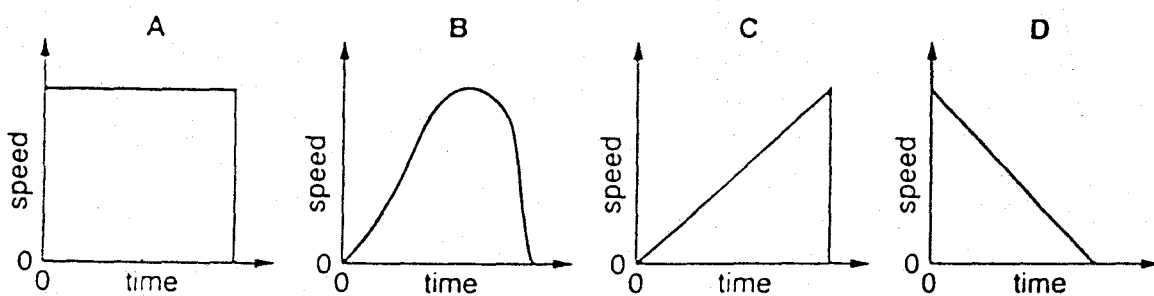

- 5 The diagram shows a book resting on a slope.

In which direction does the weight of the book act?

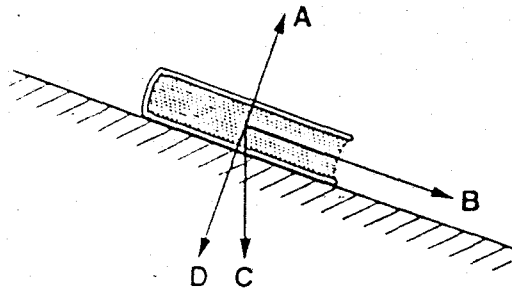

- 6 An astronaut has a mass of 60 kg on the Moon.

What is the mass of this astronaut on Earth?

- A 6 kg      B 60 kg      C 60 N      D 600 N
- 7 The table shows information about four objects.

object	mass/g	volume/cm <sup>3</sup>
P	30	6
Q	40	5
R	50	10
S	50	4

Which two objects have the same density?

- A P and Q      B P and R      C Q and S      D R and S

- 8 A student tries to balance a 10 kg bag of rice on a pivoted beam, using a 5 kg bag of rice.

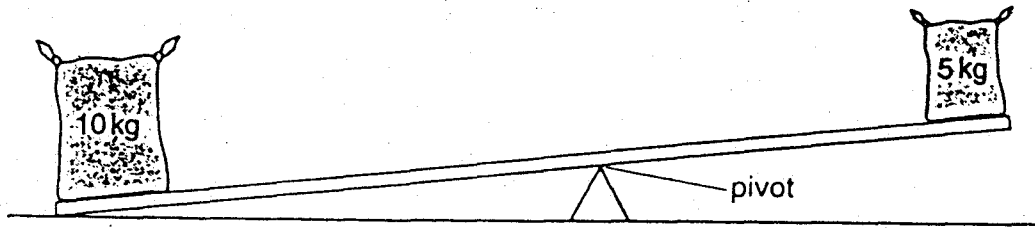

What should be done to balance the bags?

- A add some rice to the 10 kg bag
  - B empty some rice out of the 5 kg bag
  - C move the pivot away from the 10 kg bag
  - D move the pivot towards the 10 kg bag
- 9 A hot-air balloon moves in the direction shown at constant speed and at constant height. W, X, Y and Z are the forces acting on the balloon.

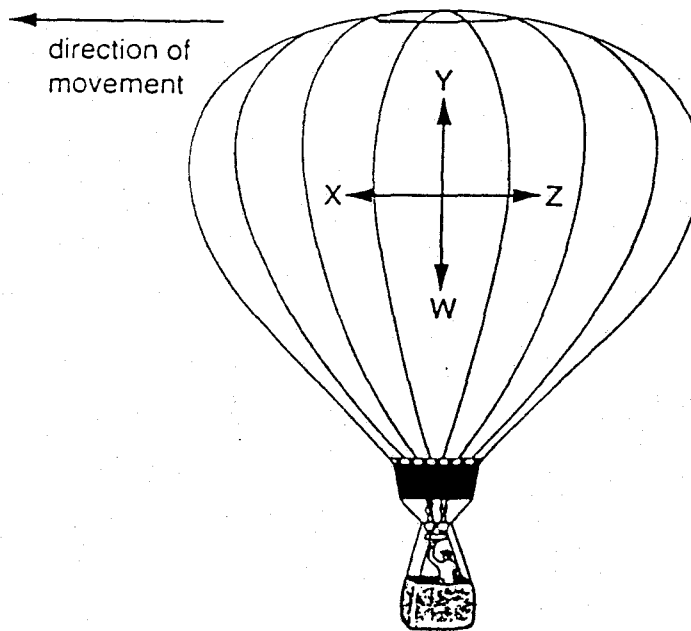

Which statement about the forces is correct?

- A Z is equal to X and W is equal to Y.
- B Z is equal to X and W is less than Y.
- C Z is less than X and W is equal to Y.
- D Z is less than X and W is less than Y.

10 The diagram shows the main parts of a hydroelectric power station.

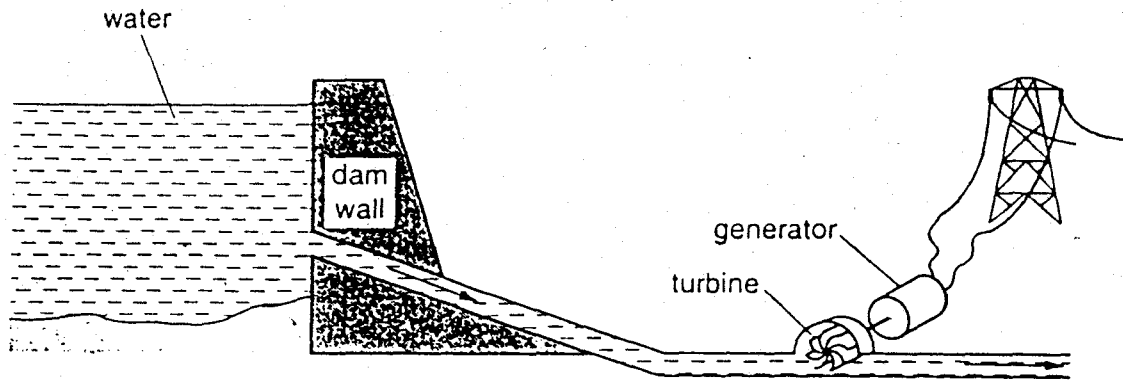

Which energy change occurs in the generator?

- A chemical to electrical
- B electrical to chemical
- C electrical to kinetic
- D kinetic to electrical

11 Forces are used to move objects P, Q, R and S through the distances shown.

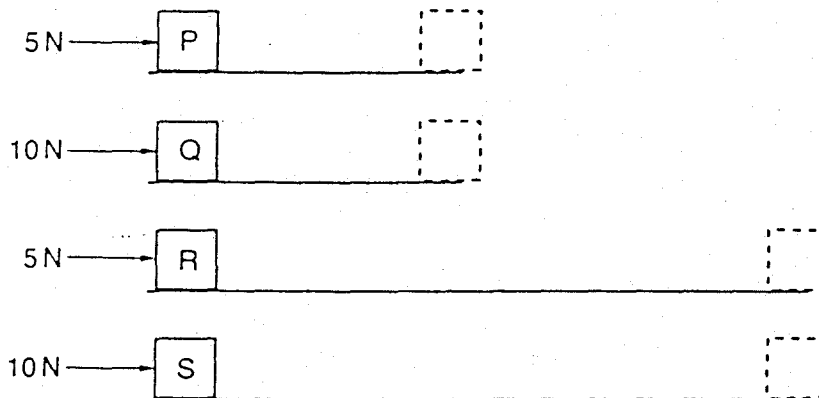

Which statement correctly describes the work done by each force?

- A Most work is done in moving R.
- B Most work is done in moving S.
- C The same amount of work is done in moving P and Q.
- D The same amount of work is done in moving P and R.

12 The diagram shows a mercury barometer.

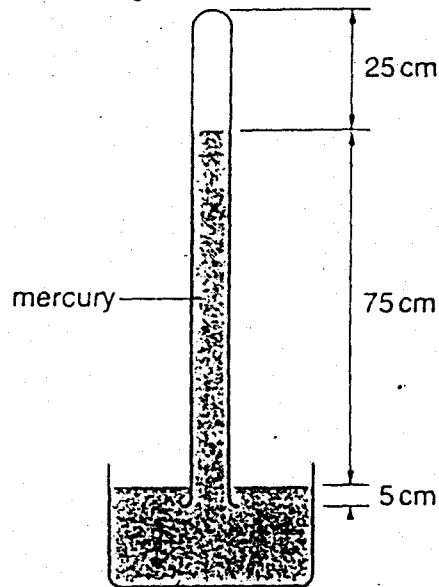

Which distance can be used to find atmospheric pressure?

- A 25 cm      B 75 cm      C 80 cm      D 100 cm

13 A child has a set of identical building blocks.

Which arrangement produces the least pressure on the floor?

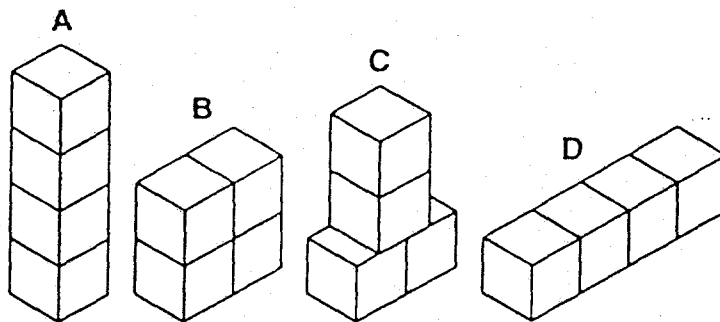

14 Liquid evaporates from an open dish.

Which molecules of liquid are most likely to escape?

- A all molecules with a little energy  
 B all molecules with a lot of energy  
 C surface molecules with a little energy  
 D surface molecules with a lot of energy

- 15 A lorry driver checks the pressure of the air in the tyres when the temperature is  $5^{\circ}\text{C}$ . After a long journey, the tyres are hot and the pressure of the air in the tyres has increased.

Why has the pressure increased?

- A Some air has leaked from the tyres during the journey.
  - B The air in the tyres is less dense.
  - C The average speed of the air molecules is greater.
  - D The tyres have expanded and have a larger volume.
- 16 Long pipes that carry steam often have bends in them, as shown.

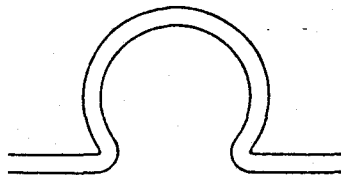

Why are these bends needed?

- A to allow for expansion
  - B to allow for pressure changes
  - C to make the pipes stronger
  - D to reduce the flow of steam
- 17 A solid substance is heated. The graph shows the change in temperature of the substance with time.

At which stage does melting take place?

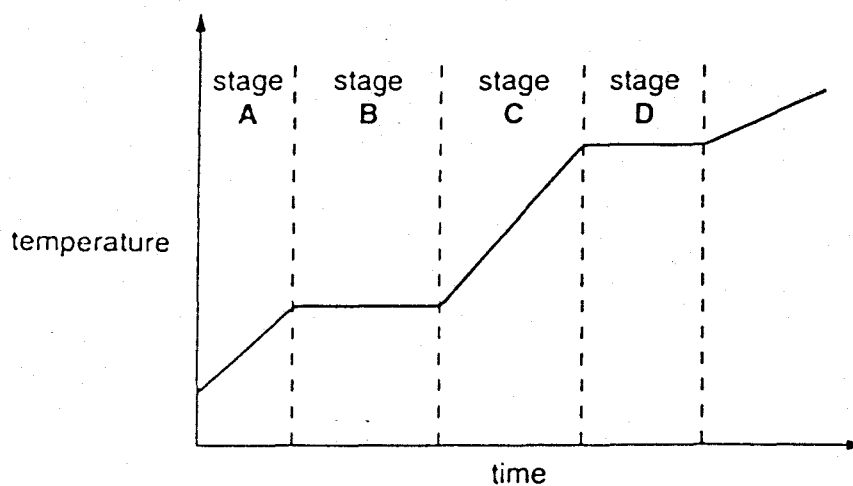



- 18 At the end of a long race, a runner is wrapped in a thin, plastic blanket that has a shiny, metallic surface.

Which type of heat loss is the shiny surface intended to reduce?

- A conduction
- B convection
- C evaporation
- D radiation

- 19 A woman stands by a fire to warm her hands and legs.



How does most of the heat reach her hands and legs?

	hands	legs
A	convection	convection
B	radiation	convection
C	convection	radiation
D	radiation	radiation

20 The diagram shows waves in a ripple tank passing from deep water to shallow water.

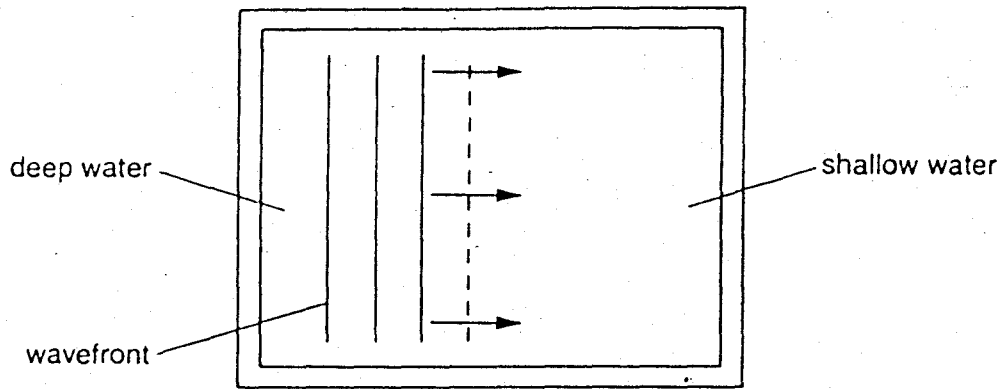

What happens to the speed and frequency of the waves?

	speed	frequency
A	decreases	decreases
B	decreases	unchanged
C	increases	increases
D	unchanged	increases

21 The diagram represents a wave.

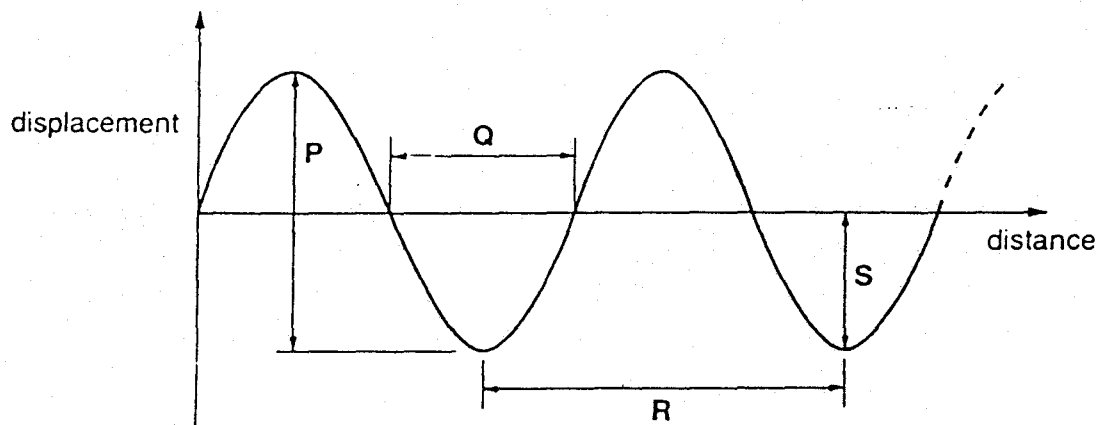

What is the amplitude and wavelength of the wave?

	amplitude	wavelength
A	P	Q
B	P	R
C	S	Q
D	S	R

22 A paper-clip is placed in front of a plane mirror.



paper-clip



plane mirror

Which diagram shows the image formed behind the mirror?

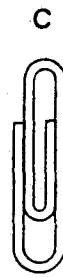

23 A ray of white light passes into each glass block as shown.

Which block produces dispersion of the light?

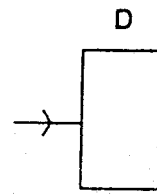
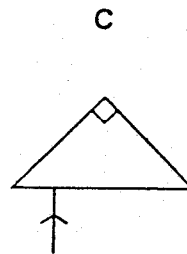
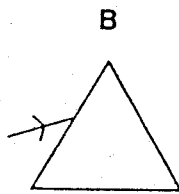
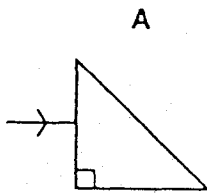

- 24 The diagram shows apparatus used to find what happens to the sound from an electric bell as air is removed from the container.

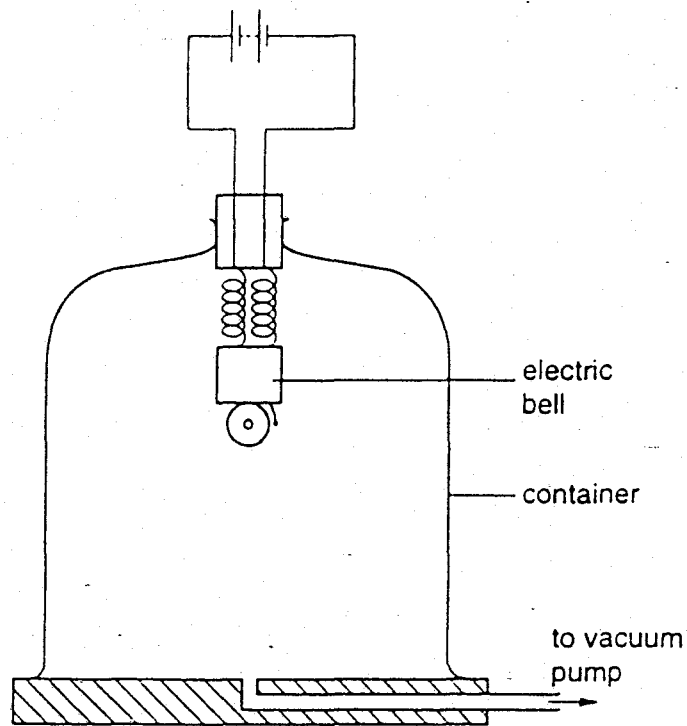

What happens to the sound of the electric bell heard from outside the container?

- A It becomes louder.
- B It becomes quieter.
- C It becomes quieter, then louder.
- D It remains the same.

25 Two students stand 600 m apart.

student with  
starting-pistol



student with  
stopwatch



600 m

not to scale

They find that it takes 2 seconds for the sound from the starting pistol to travel from one student to the other.

From these results, what is the speed of sound in air?

- A 150 m/s      B 300 m/s      C 600 m/s      D 1200 m/s

26 A piece of soft iron is placed in a coil. The switch is then closed.

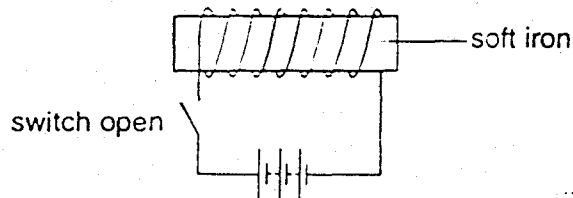

What is the condition of the soft iron when the switch is open and when the switch is closed?

	switch open	switch closed
A	magnetised	magnetised
B	magnetised	unmagnetised
C	unmagnetised	magnetised
D	unmagnetised	unmagnetised

27 When a magnet is brought near some metals, it induces magnetic poles in the metals.

Which diagram shows the poles induced when a magnet is brought near to an unmagnetised piece of iron and to an unmagnetised piece of aluminium?

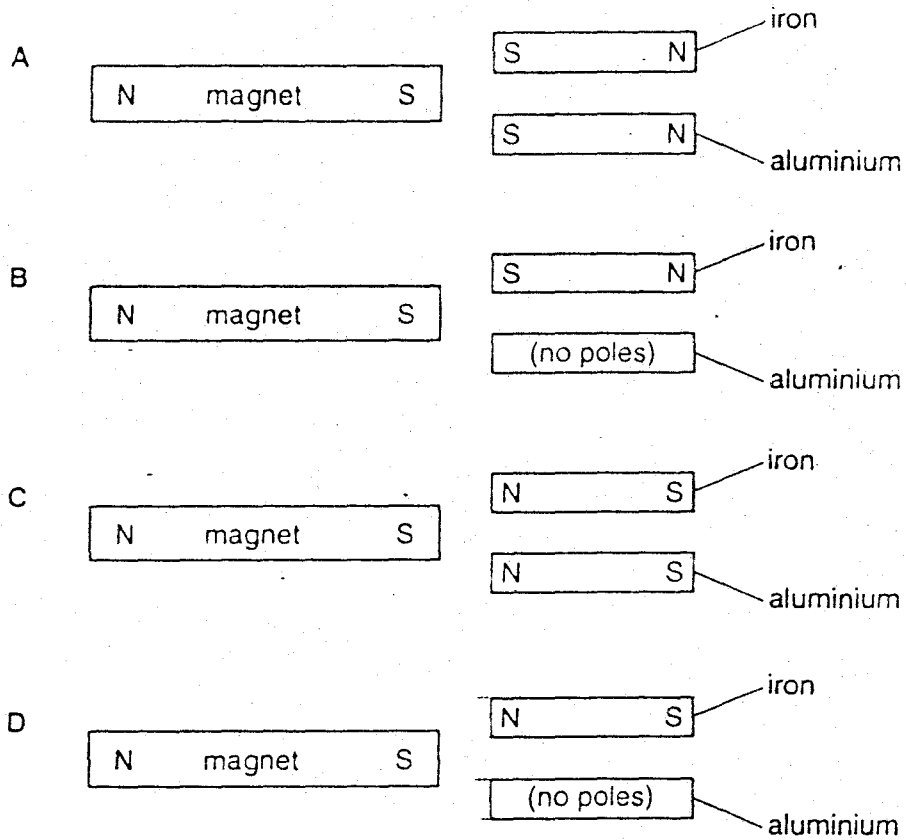

28 Which circuit shows how a voltmeter is connected to measure the potential difference across the cell?

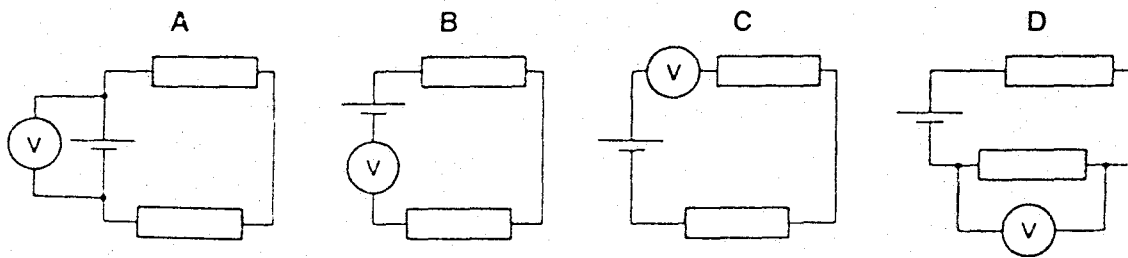

29 Which diagram shows the directions of the electrostatic forces acting on two positively charged spheres?

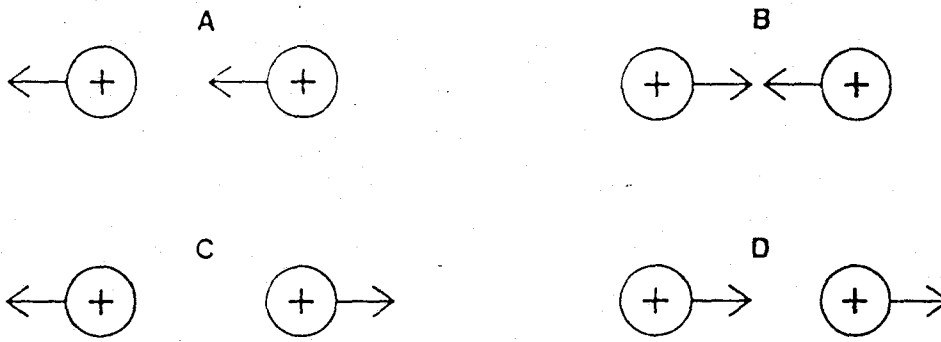

30 What is the correct symbol for a fuse?

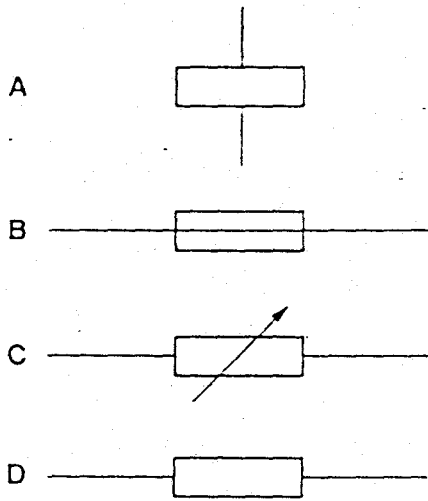

31 In which circuit is lamp  $L_1$  lit, but lamp  $L_2$  unlit?

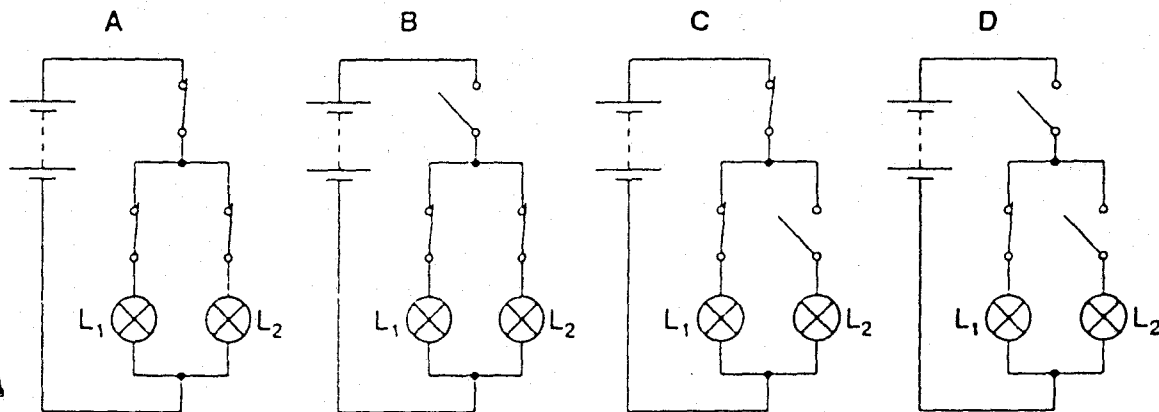

32 The diagram shows the structure of a fuse.

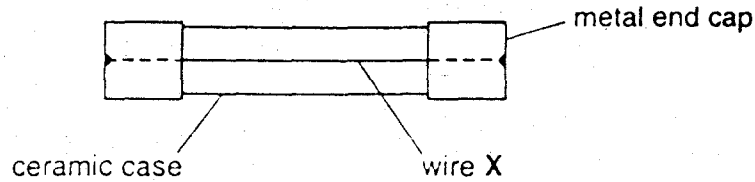

What is the purpose of wire X?

- A to decrease the resistance of the circuit
  - B to increase the current in the circuit
  - C to keep the end caps on
  - D to melt when the current becomes too large
- 33 A wiring diagram for car headlamps and parking lamps is shown.

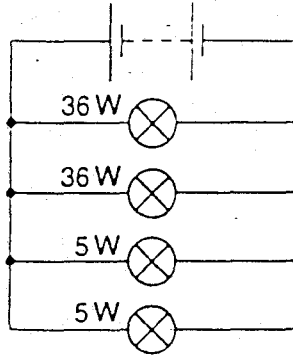

Why are the lamps connected in parallel?

- A so that, if one lamp goes out, the others will remain lit
- B so that the current in each lamp is the same
- C so that the lamps operate at normal brightness, even when the battery runs down
- D so that the voltage across each lamp is one quarter of the battery voltage



34 The diagram shows a step-up transformer.

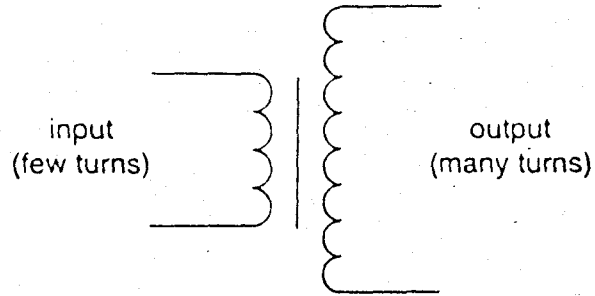

What is stepped up by this type of transformer?

- A current
- B energy
- C power
- D voltage

35 Which diagram shows how a coil of wire and a magnet can be used to produce an electric current through a meter?

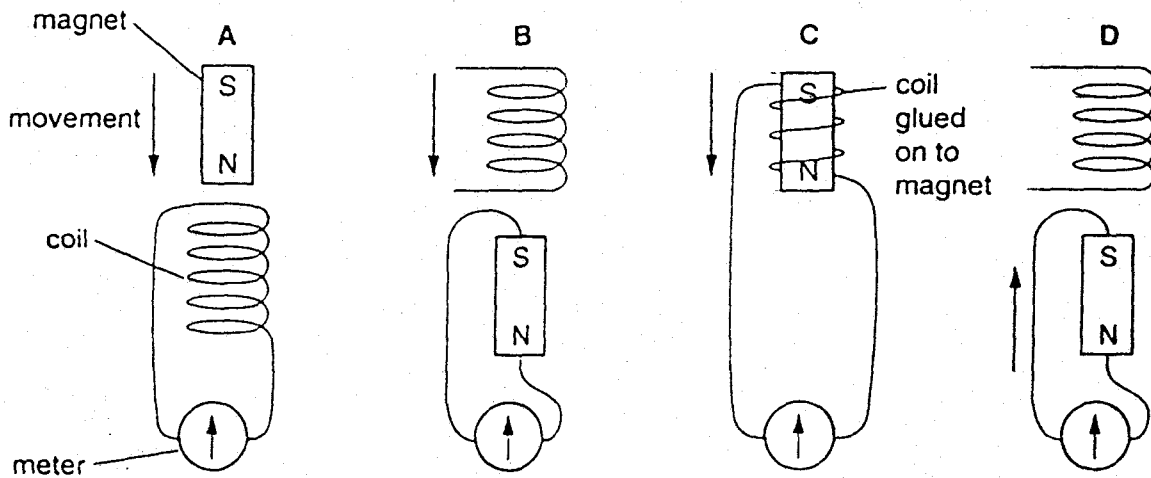

36 The diagram shows part of an alarm circuit.

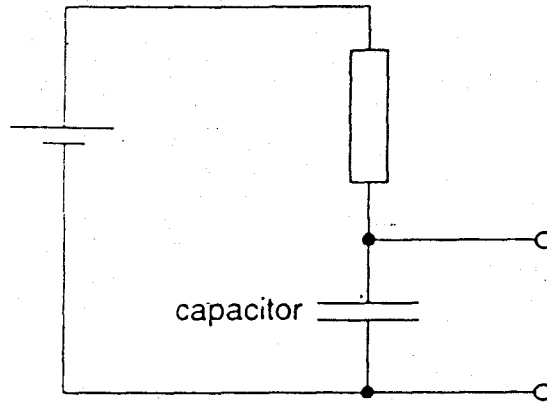

What does the capacitor do?

- A It detects changes in light intensity.
- B It detects changes in temperature.
- C It produces a magnetic field.
- D It stores electrical energy.

37 The charges on the x-plates and y-plates of a cathode-ray oscilloscope cause the spot on the screen to move to the position shown.

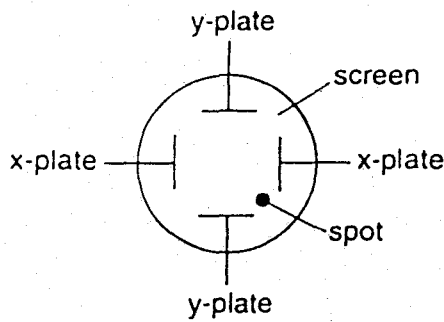

Which diagram shows how the plates are charged?

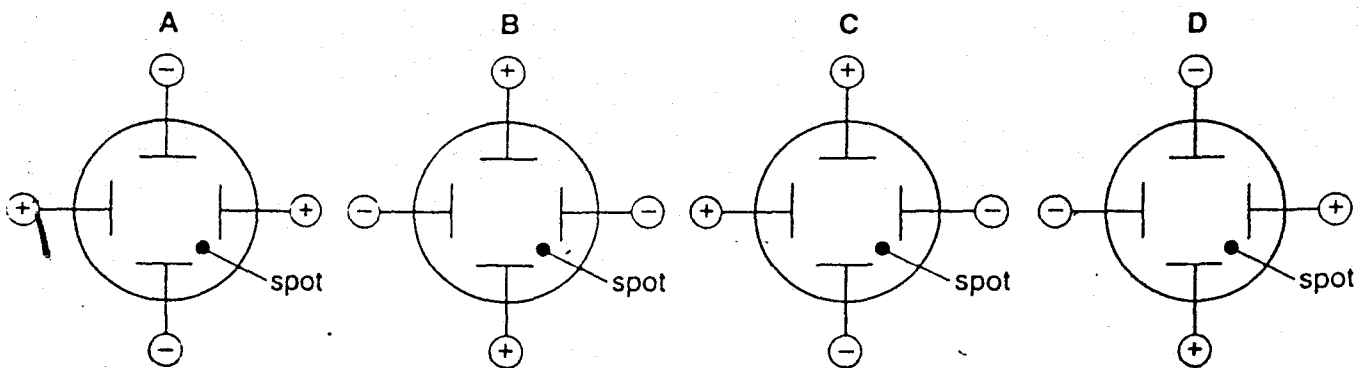

- 38 A piece of paper is placed between a radioactive source and a detector. What are the possible radiations that can pass through the paper?
- A alpha ( $\alpha$ -) radiation only.  
 B alpha ( $\alpha$ -) and gamma ( $\gamma$ -) radiation only.  
 C beta ( $\beta$ -) and gamma ( $\gamma$ -) radiation only.  
 D alpha ( $\alpha$ -), beta ( $\beta$ -) and gamma ( $\gamma$ -) radiation.
- 39 The graph shows how the activity of a radioactive substance changes with time.

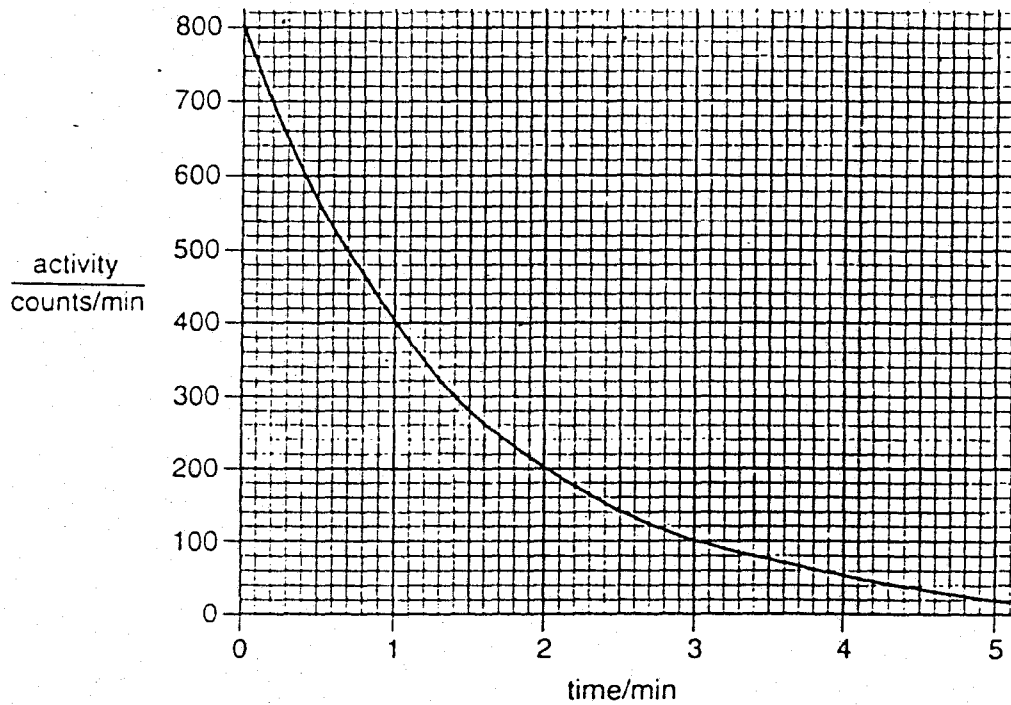

What is the half-life of the substance?

- A 1 min      B 2 min      C 3 min      D 4 min
- 40 The diagram represents a helium atom.

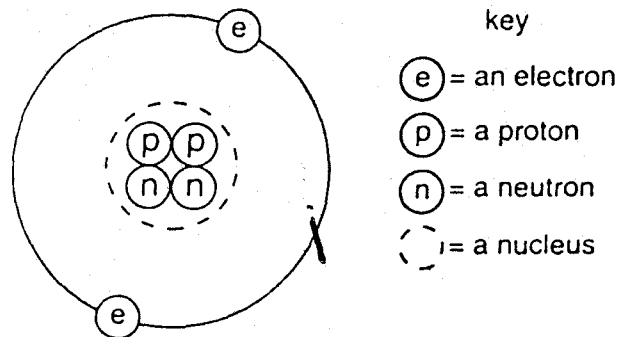

What is the nucleon number (mass number) of the atom?

- A 2      B 4      C 6      D 8