



UNIVERSITY OF CAMBRIDGE INTERNATIONAL EXAMINATIONS  
International General Certificate of Secondary Education

CANDIDATE  
NAME

CENTRE  
NUMBER

--	--	--	--	--

CANDIDATE  
NUMBER

--	--	--	--

\* 1 8 7 5 4 6 4 1 8 3 \*

**PHYSICAL SCIENCE**

**0652/06**

Paper 6 Alternative to Practical

**October/November 2009**

**1 hour**

Candidates answer on the Question Paper.

No Additional Materials are required.

**READ THESE INSTRUCTIONS FIRST**

Write your Centre number, candidate number and name on all the work you hand in.

Write in dark blue or black pen.

You may use a soft pencil for any diagrams or graphs.

Do not use staples, paper clips, highlighters, glue or correction fluid.

**DO NOT WRITE IN ANY BARCODES.**

Answer **all** questions.

At the end of the examination, fasten all your work securely together.

The number of marks is given in brackets [ ] at the end of each question or part question.

For Examiner's Use	
<b>1</b>	
<b>2</b>	
<b>3</b>	
<b>4</b>	
<b>5</b>	
<b>6</b>	
<b>Total</b>	

This document consists of **19** printed pages and **5** blank pages.



- 1 A student has found three automobile lamps at the scrap yard. The student finds some printing on the lamps, and copies this into Fig. 1.1.

lamp	what is printed on the lamp
1	24 V 36 W
2	12 V 18 W
3	6 V 18 W

Fig. 1.1

He wants to compare the resistances of the three lamps using the circuit shown in Fig. 1.2.

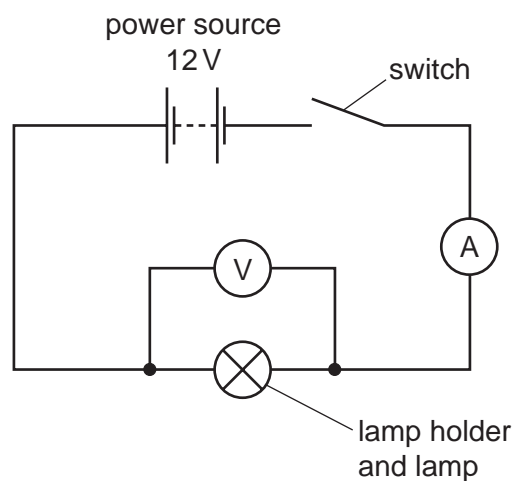


Fig. 1.2

- The student inserts lamp 1 into the lampholder.
- He closes the switch.
- He reads the voltmeter and ammeter and records the readings in Fig. 1.3.
- He repeats the experiment using lamp 2.

lamp	voltmeter reading /V	ammeter reading /A	brightness of the lamp
1	11.9	0.72	dim
2			bright

Fig. 1.3

- (a) The ammeter and voltmeter readings for lamp 2 are shown in Fig. 1.4. Record the readings in Fig. 1.3.

[2]

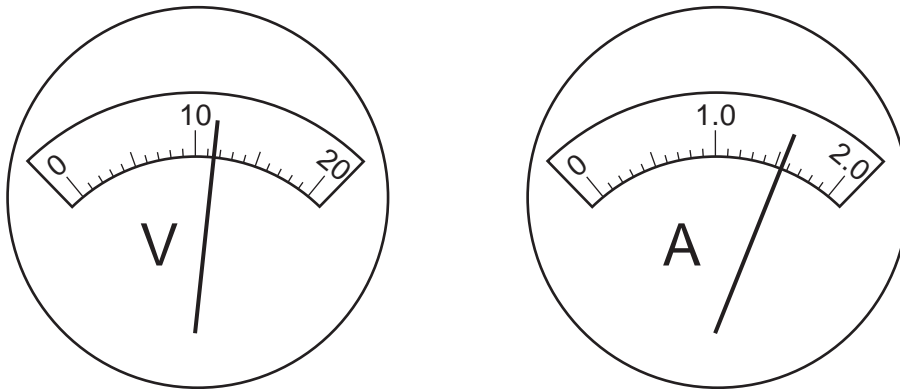
For  
Examiner's  
Use

Fig. 1.4

- (b) The student wants to use the equation  $V = IR$  to find the resistance of the lamps 1 and 2.

- (i) Rearrange the equation  $V = IR$ .

$$R = \dots\dots\dots [1]$$

- (ii) Calculate the resistance of lamp 1 using the data from Fig. 1.3.

$$\text{resistance of lamp 1} = \dots\dots\dots \text{ohms} [1]$$

- (iii) Calculate the resistance of lamp 2 using the data from Fig. 1.3.

$$\text{resistance of lamp 2} = \dots\dots\dots \text{ohms} [1]$$

- (c) The student repeats the experiment with lamp 3. He fixes the lamp in the lampholder and closes the switch. The lamp glows brightly for a short time and then the ammeter reading falls to 0.

Use data from Fig. 1.1 and 1.3 to help you to explain what happened to lamp 3 when the student used it in the circuit.

.....  
.....  
..... [2]

- (d) (i) Use data from Fig. 1.1 and Fig. 1.3 to suggest a reason why lamp 1 gave only a dim light.

.....  
..... [1]

- (ii) Calculate the power in watts of lamp 2, using data from Fig. 1.3.

power of lamp 2 = ..... watts [2]

**BLANK PAGE**

**Please turn over for Question 2.**

- 2 Potassium manganate(VII) (potassium permanganate) is a dark crystalline substance. Its solution in water is dark purple. Potassium permanganate solution reacts with solution **X**. When the reaction is complete the purple colour disappears.

For  
Examiner's  
Use

A student uses a dropping pipette and solution **X** to find out which one of three potassium permanganate solutions, **A**, **B** or **C** is the most concentrated. The apparatus is shown in Fig. 2.1.

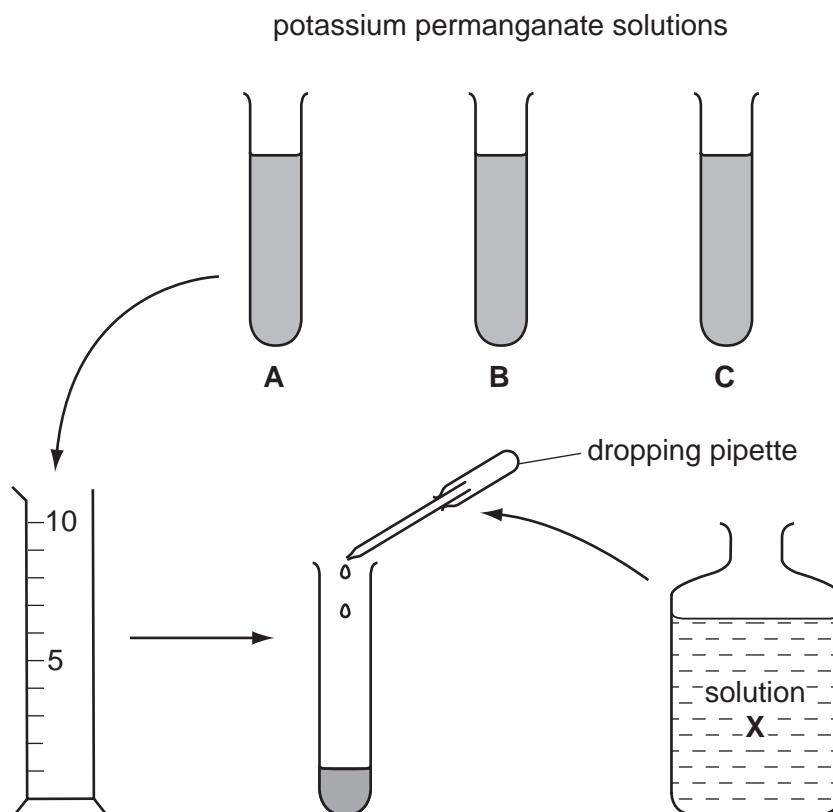


Fig. 2.1

#### Procedure

- She measures out some of solution **A** and pours it into a test-tube.
- She fills the dropping pipette with solution **X**.
- She adds solution **X** drop by drop to solution **A**, counting the drops, until the reaction has finished.
- She records the number of drops added in Fig. 2.2.
- She repeats the experiment using solutions **B** and **C**.

solution	number of drops used
<b>A</b>	15
<b>B</b>	24
<b>C</b>	18

Fig. 2.2

- (a) (i) What must the student do to make a fair comparison between the three solutions **A**, **B** and **C**?

..... [1]

- (ii) How will she make sure that all the reacting particles come into contact with each other when the drops are added ?

..... [1]

- (iii) How will she know when to stop adding the drops of solution **X**?

..... [1]

- (iv) Which is the most concentrated of the solutions, **A**, **B** or **C**?

..... [1]

- (b) Suggest a way, using the apparatus in Fig. 2.1, of finding the accurate volume of one drop of liquid from the teat pipette.

.....  
 .....  
 ..... [2]

- (c) The student carries out tests on solution **X**. She writes the results in Fig. 2.3.

Complete Fig. 2.3.

test	observation	conclusion
(i) To 2 cm <sup>3</sup> of solution <b>X</b> , add a few drops of dilute hydrochloric acid followed by aqueous barium chloride.	..... ..... [1]	solution <b>X</b> contains sulfate ions
(ii) To 2 cm <sup>3</sup> of solution <b>X</b> , add aqueous sodium hydroxide until no further change occurs.	..... ..... [1]	solution <b>X</b> contains iron(II) ions

Fig. 2.3

The student wants to discover the product of the reaction of solution **X** with potassium permanganate.

She places 2 cm<sup>3</sup> of potassium permanganate solution in a test-tube. She adds dilute sulfuric acid. Then she carefully adds solution **X** drop by drop until the reaction is complete. To the mixture, she adds aqueous sodium hydroxide until no further change occurs. She observes a brown precipitate.

*For  
Examiner's  
Use*

**(d) (i)** Suggest the name of this brown precipitate.

..... [1]

**(ii)** What happens to the iron(II) ions when they react with potassium permanganate?

..... [1]



**BLANK PAGE**

**Please turn over for Question 3.**

- 3 A student is investigating the path of a light ray through a parallel-sided glass block as shown in Fig. 3.1. Look at Fig. 3.1.

For  
Examiner's  
Use

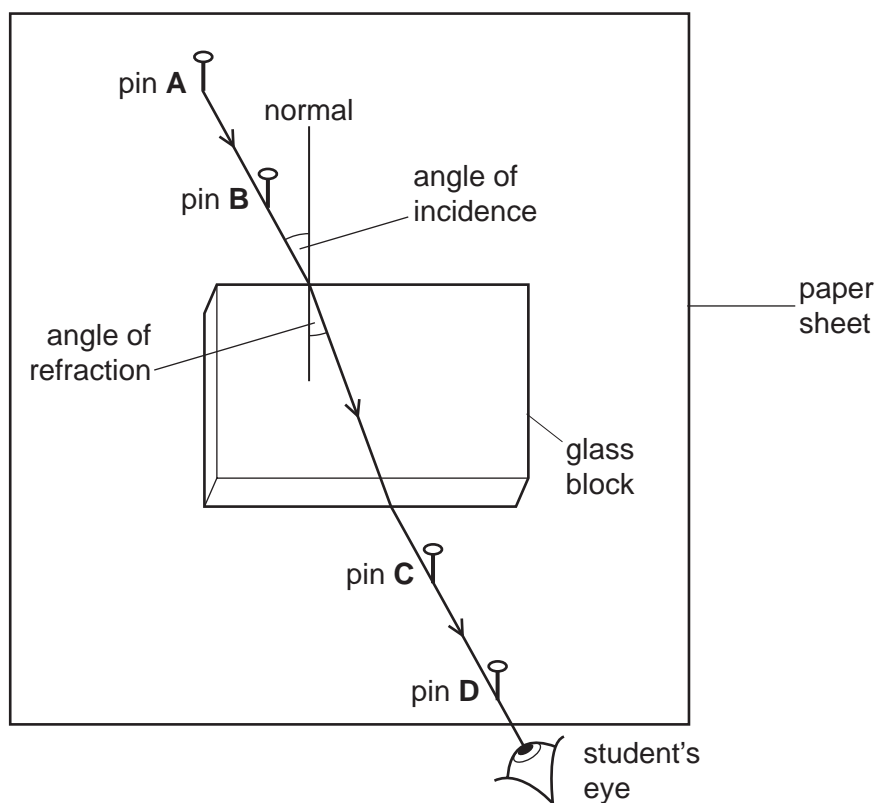
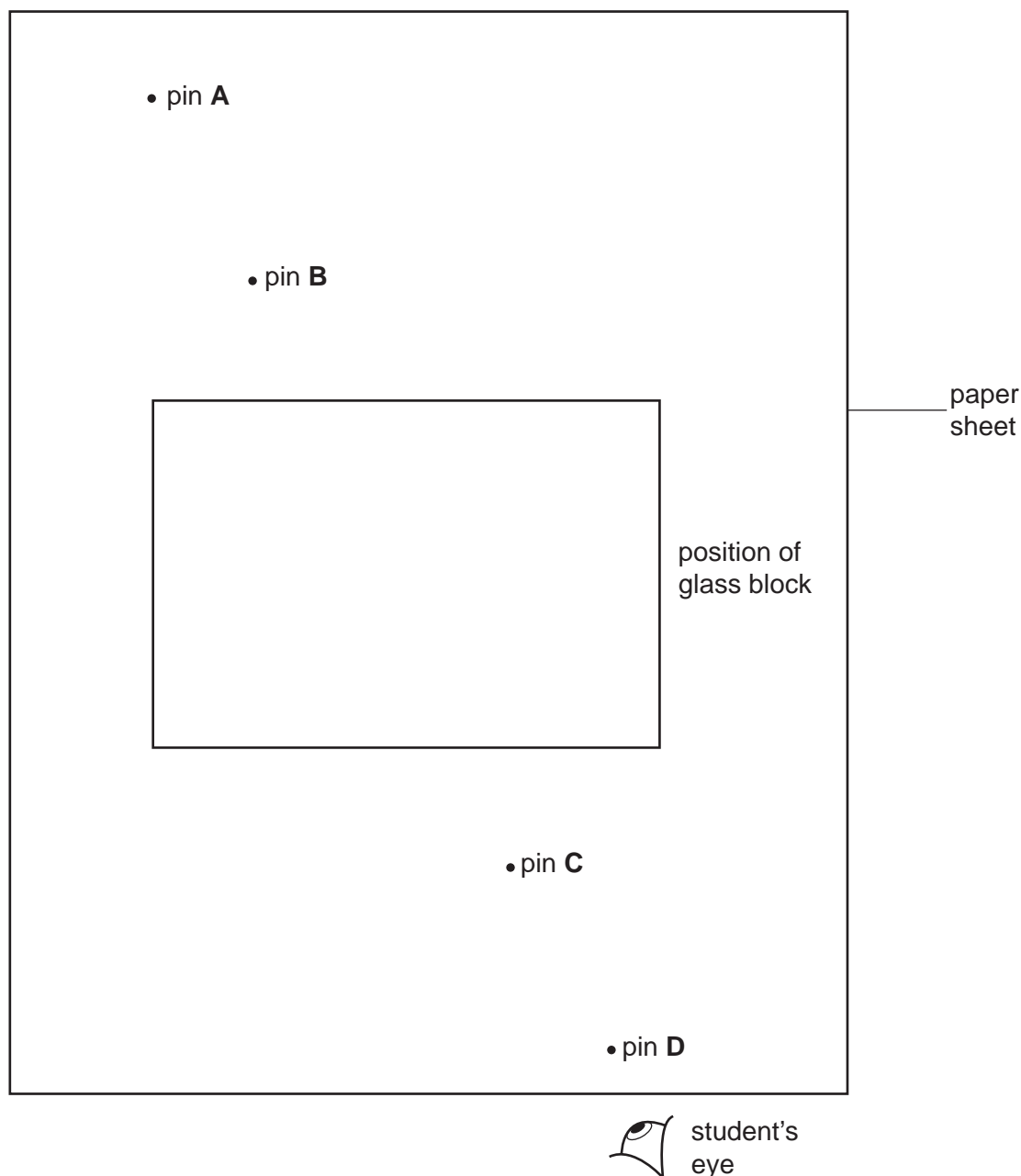


Fig. 3.1

- He places the glass block on a sheet of paper on top of a flat piece of soft wood.
- He draws a line on the paper all round the glass block.
- He places two upright pins, **A** and **B**, in a line, at an angle to the side of the block.
- Then he looks through the glass block at the two pins.
- When he sees the two pins **A** and **B** in line, he places pins **C** and **D** on his side of the block, in line with pins **A** and **B**.
- He removes the glass block and draws the path of a ray of light through the block.

Fig. 3.2 shows the piece of paper after the glass block has been removed.

For  
Examiner's  
Use



**Fig. 3.2**

- (a) (i) On Fig. 3.2, draw the path of a light ray that travels from pin **A** through the glass block into the student's eye. [1]
- (ii) Draw the normal where the incident ray enters the glass block. See Fig. 3.1. [1]
- (iii) On Fig. 3.2, label **i**, the angle of incidence, and **r**, the angle of refraction. [1]
- (iv) On Fig. 3.2, measure **i**, the angle of incidence and **r**, the angle of refraction to the nearest degree. Record them in the first line of Fig. 3.3, on page 12. [2]

The student repeats the experiment, changing the angle of incidence each time, to give four more sets of readings. He records them in Fig. 3.3.

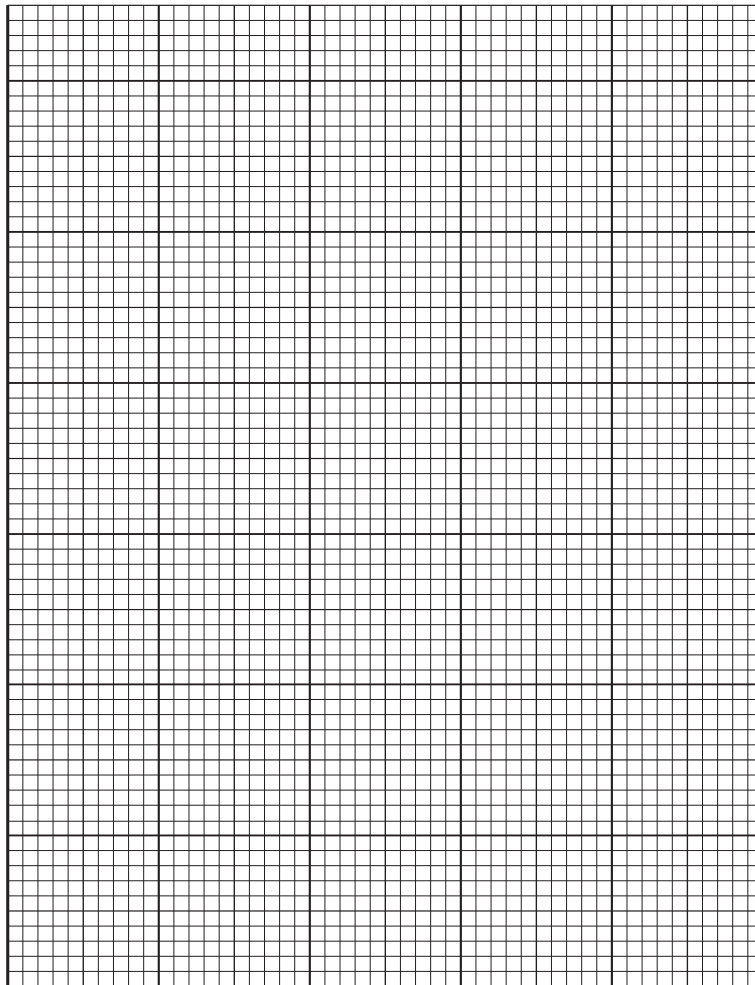
angle of incidence $i$ / degrees	angle of refraction $r$ / degrees
38	24
46	28
54	32
63	35

For  
Examiner's  
Use

**Fig. 3.3**

- (b) On the graph grid provided, plot a graph of  $i$  (vertical axis) against  $r$ .  
Draw a smooth curve. Do not try to extend the line beyond the plotted points.

[3]



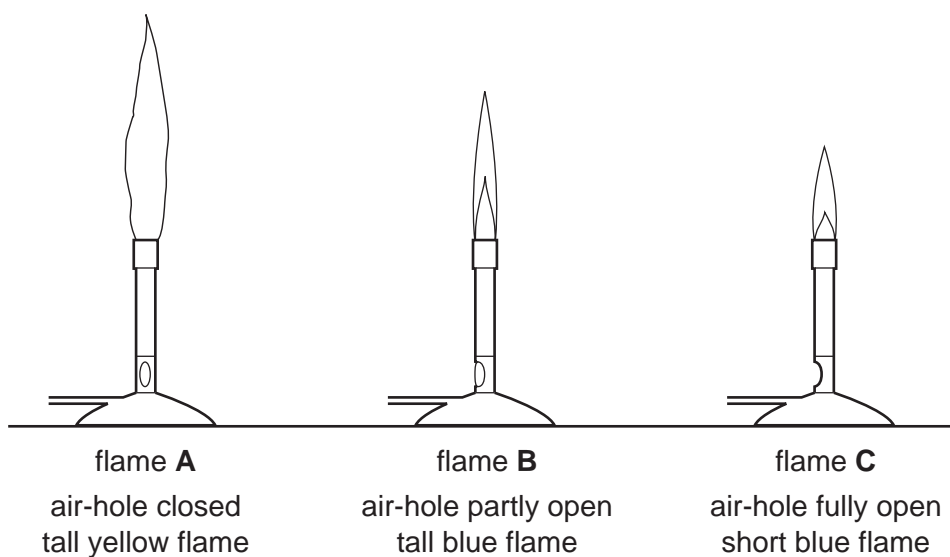
- (c) Use your graph to determine the angle of incidence when the angle of refraction is  $26^\circ$ . Show how you do this on the graph.

*For  
Examiner's  
Use*

angle of incidence = .....degrees [2]

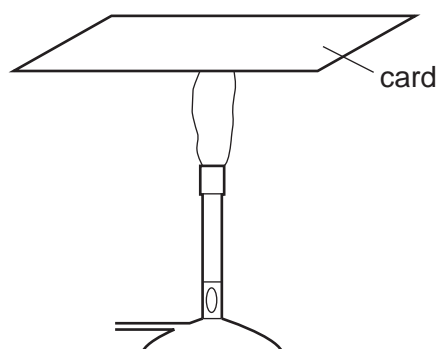
- 4 The science class is doing experiments with Bunsen burners. The gas used in the burners is butane,  $C_4H_{10}$ . A student finds out that he can get three different types of flame using his Bunsen burner. These are shown in Fig. 4.1.

For  
Examiner's  
Use

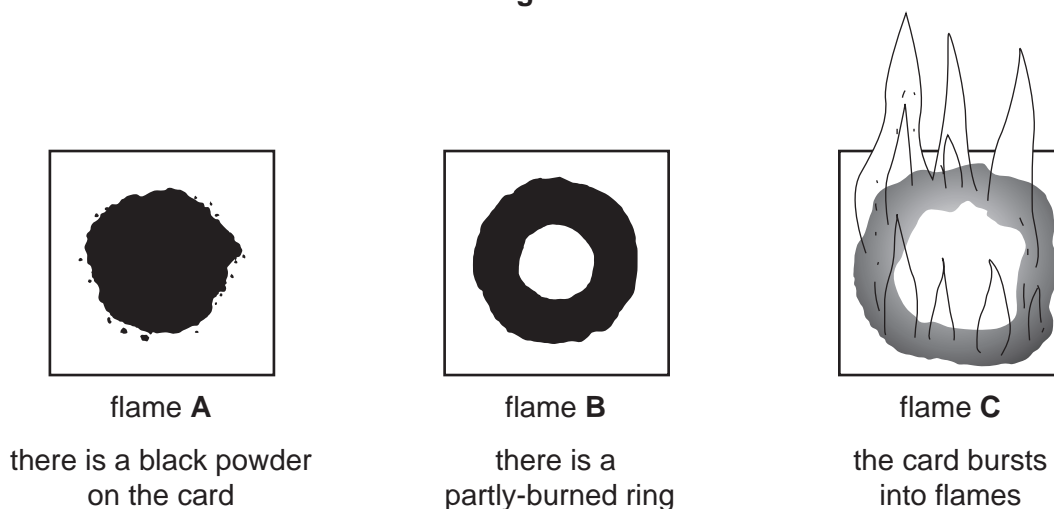


**Fig. 4.1**

- (a) He holds a thin white card horizontally in each flame for about 5 seconds, as shown in Fig. 4.2. The results are shown in Fig. 4.3.



**Fig. 4.2**



**Fig. 4.3**

(i) Explain why black soot forms on the card in flame **A**.

.....  
 .....  
 ..... [2]

(ii) Suggest why there is a partly-burned ring with an unburned centre, on the card that was held in flame **B**.

.....  
 .....  
 ..... [2]

The teacher gives the student a sample of sodium nitrate crystals in a test-tube. The student heats the tube in each flame for 3 minutes, beginning with flame **A**. Fig. 4.4 shows the results.

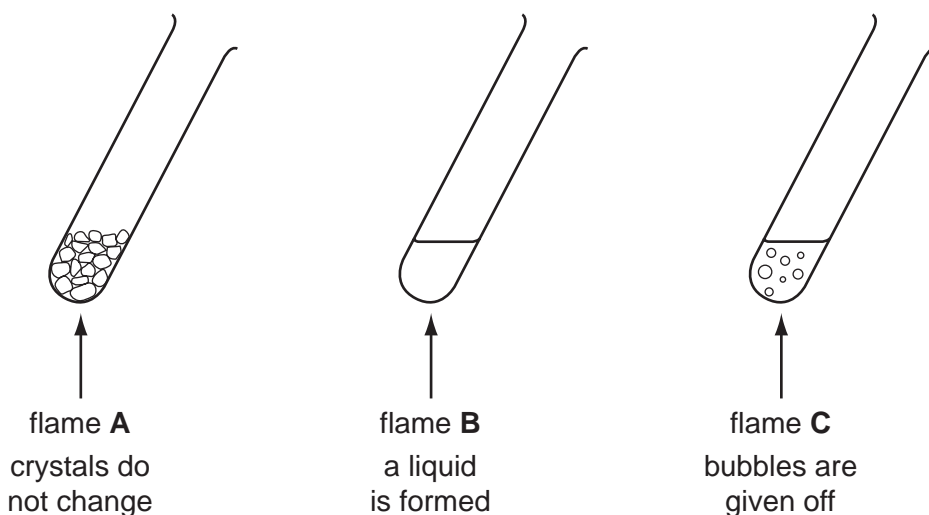


Fig. 4.4

(b) Use **one word** in each case to suggest what happens to the sodium nitrate when it is heated.

- (i) In flame **B**, the sodium nitrate ..... [1]  
 (ii) In flame **C**, the sodium nitrate ..... [1]

(c) The student thinks that oxygen is being given off from the sodium nitrate in flame **C**.

Explain how he can show that the gas given off is oxygen. Give all necessary details of the test.

.....  
.....  
..... [2]

(d) The teacher asks the student to explain why flame **C** is hotter than the other flames.

Suggest why flame **C** is the hottest.

.....  
.....  
.....  
..... [2]



- 5 Two students want to find out how high they can hit a ball. While student **a** hits a ball as high as he can into the air, student **B** uses a stopclock. He starts the clock when the ball is hit and stops it when the ball hits the ground  $t$  seconds later. Then student **B** hits the ball and student **A** uses the stopclock.

For  
Examiner's  
Use

Fig. 5.1 shows how the ball moves through the air.

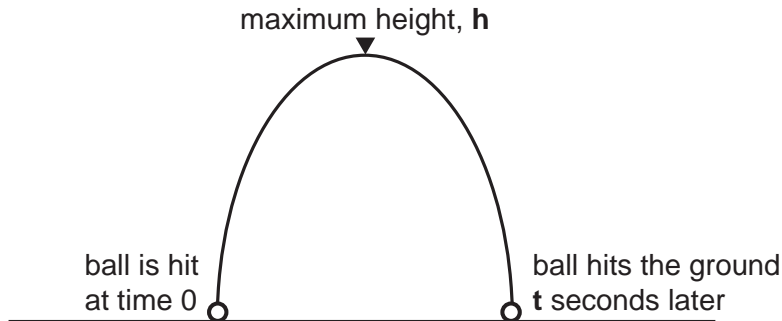


Fig. 5.1

They record time  $t$  for each student's ball in Fig. 5.2.

The students decide that the ball takes  $\frac{t}{2}$  seconds to fall from the maximum height,  $h$ , to the ground.

student	A	B
time $t$ /s		
time, $\frac{t}{2}$ , to fall from height $h$ to the ground/s		

Fig. 5.2

(a) Fig. 5.3 shows the stopclock dials for each student's ball.

- (i) Read the dials and record the readings in Fig. 5.2. [1]

- (ii) Complete Fig. 5.2. [1]

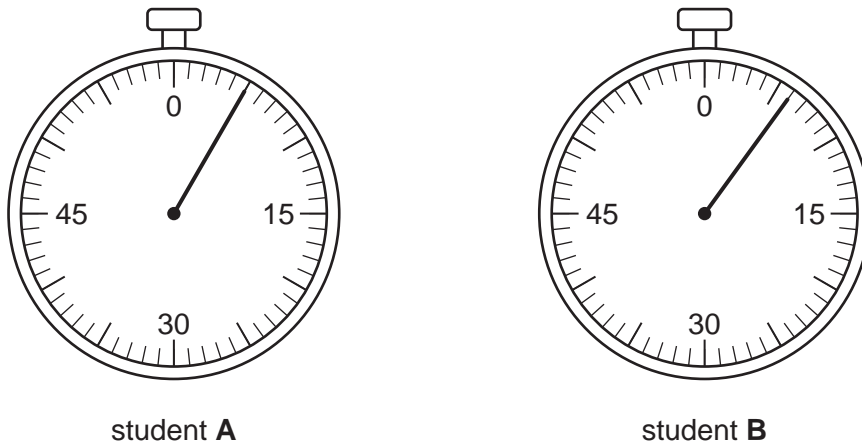


Fig. 5.3

The students know that the acceleration due to gravity,  $g$ , has a value of about  $10 \text{ m/s}^2$ . They use this fact to draw a speed-time graph, shown in Fig. 5.4. This shows how the speed of the ball changes as it falls from the maximum height,  $h$ , to the ground.

For  
Examiner's  
Use

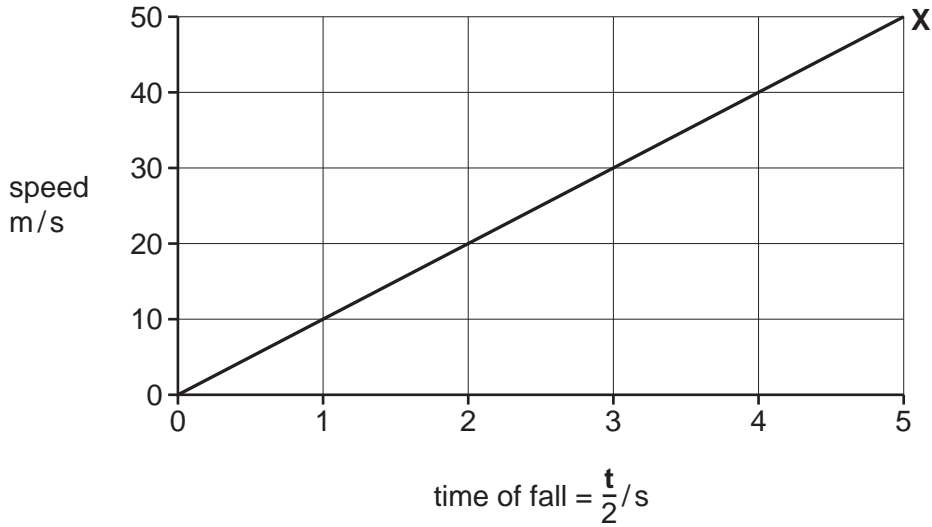


Fig. 5.4

- (b) (i) On Fig. 5.4, Draw a vertical line for the time of fall of student **A**'s ball so that it meets the line **OX**. [1]
- (ii) Find the distance travelled by student **A**'s ball by calculating the area enclosed under the graph. This is equal to the maximum height,  $h$ , of the ball.

maximum height of student **A**'s ball = ..... m [2]

- (iii) In the same way, find the maximum height of student **B**'s ball.

maximum height of student **B**'s ball = ..... m [2]

- (c) The ball was given energy by the student. Describe the energy changes by completing the paragraph below.

For  
Examiner's  
Use

The student's body used ..... energy when hitting the ball.

The ball gained ..... energy when it was hit. At the

maximum height **h**, the ball possessed ..... energy.

This was changed into ..... energy just before the ball

hit the ground. The energy was converted into ..... energy and

..... energy when the ball hit the ground. [3]

6 A student investigated the reactions of the alkali metals lithium, sodium and potassium with cold water.

- He took a piece of lithium out of the jar.
- He wiped off the mineral oil.
- He cut a small piece of lithium.
- He placed the piece of lithium on the surface of water in a large container. See Fig. 6.1.
- He wrote his observations in Fig. 6.2.
- He repeated the experiment using sodium and potassium.

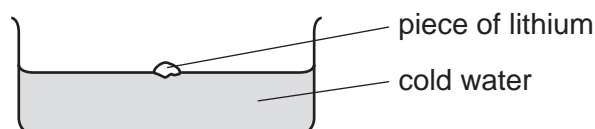


Fig. 6.1

alkali metal	observations
lithium	The lithium floated and moved around on the surface. A fizzing was heard. The lithium did not melt. It took 30 seconds to react and disappear.
sodium	The sodium reacted more vigorously than the lithium.
potassium	The potassium reacted more vigorously than the sodium.

Fig. 6.2

(a) Suggest two observations that the student could make to show that the sodium reacted more vigorously than the lithium.

- 1 .....
- 2 ..... [2]

(b) Suggest **one** observation that the student could make to show that the potassium reacted more vigorously than the sodium.

..... [1]

(c) The student thought that a gas was given off when lithium reacted with water.

Draw a diagram of the apparatus he can use to react a piece of lithium with cold water and collect the gas given off.

For  
Examiner's  
Use

[2]

(d) (i) Write a word equation for the reaction of sodium with cold water.

.....  
..... [2]

(ii) Describe tests that can be used to confirm the presence of the **two** products of the reaction in (d)(i), one test for each product.

.....  
.....  
.....  
..... [3]





---

Permission to reproduce items where third-party owned material protected by copyright is included has been sought and cleared where possible. Every reasonable effort has been made by the publisher (UCLES) to trace copyright holders, but if any items requiring clearance have unwittingly been included, the publisher will be pleased to make amends at the earliest possible opportunity.

University of Cambridge International Examinations is part of the Cambridge Assessment Group. Cambridge Assessment is the brand name of University of Cambridge Local Examinations Syndicate (UCLES), which is itself a department of the University of Cambridge.