

Centre Number	Candidate Number	Name
---------------	------------------	------

UNIVERSITY OF CAMBRIDGE INTERNATIONAL EXAMINATIONS  
International General Certificate of Secondary Education

**PHYSICAL SCIENCE**

**0652/05**

Paper 5 Practical Test

October/November 2004

**1 hour 30 minutes**

Candidates answer on the Question Paper.

Additional Materials: As listed in Instructions to Supervisors

**READ THESE INSTRUCTIONS FIRST**

Write your Centre number, candidate number and name on all the work you hand in.  
Write in dark blue or black pen in the spaces provided on the Question Paper.  
You may use a soft pencil for any diagrams, graphs or rough working.  
Do not use staples, paper clips, highlighters, glue or correction fluid.

Answer **all** questions.

At the end of the examination, fasten all your work securely together.

The number of marks is given in brackets [ ] at the end of each question or part question.

Chemistry practical notes for this paper are printed on page 8.

If you have been given a label, look at the details. If any details are incorrect or missing, please fill in your correct details in the space given at the top of this page.

Stick your personal label here, if provided.

For Examiner's Use	
1	
2	
Total	

This document consists of 7 printed pages and 1 blank page.



- 1 You are required to find out how the rate of the reaction between hydrochloric acid and magnesium changes with the concentration of the hydrochloric acid.

**P** is a solution of hydrochloric acid, concentration  $2.0 \text{ mol/dm}^3$ .

- (a)
- Place  $80 \text{ cm}^3$  of solution **P** in a beaker.
  - Cut a  $2.0 \text{ cm}$  strip of magnesium.
  - Drop the magnesium into solution **P** and start the clock.
  - Find the time taken in seconds, for the magnesium to disappear. Record this time in Fig. 1.1

volume of solution <b>P</b> / $\text{cm}^3$	volume of water/ $\text{cm}^3$	concentration of acid in $\text{mol/dm}^3$	time taken for magnesium to dissolve/s
80	0	2.0	
60	20	1.5	
40	40	1.0	
20	60	0.5	

**Fig. 1.1**

- (b) Repeat the experiment three more times, using a different concentration of hydrochloric acid each time. The different concentrations are prepared by mixing amounts of solution **P** and water shown in Fig. 1.1. Find the time taken for the magnesium to disappear for each experiment and record it in Fig. 1.1.

[6]

- (c) (i) Plot a graph of time (vertical axis) against the concentration of hydrochloric acid.

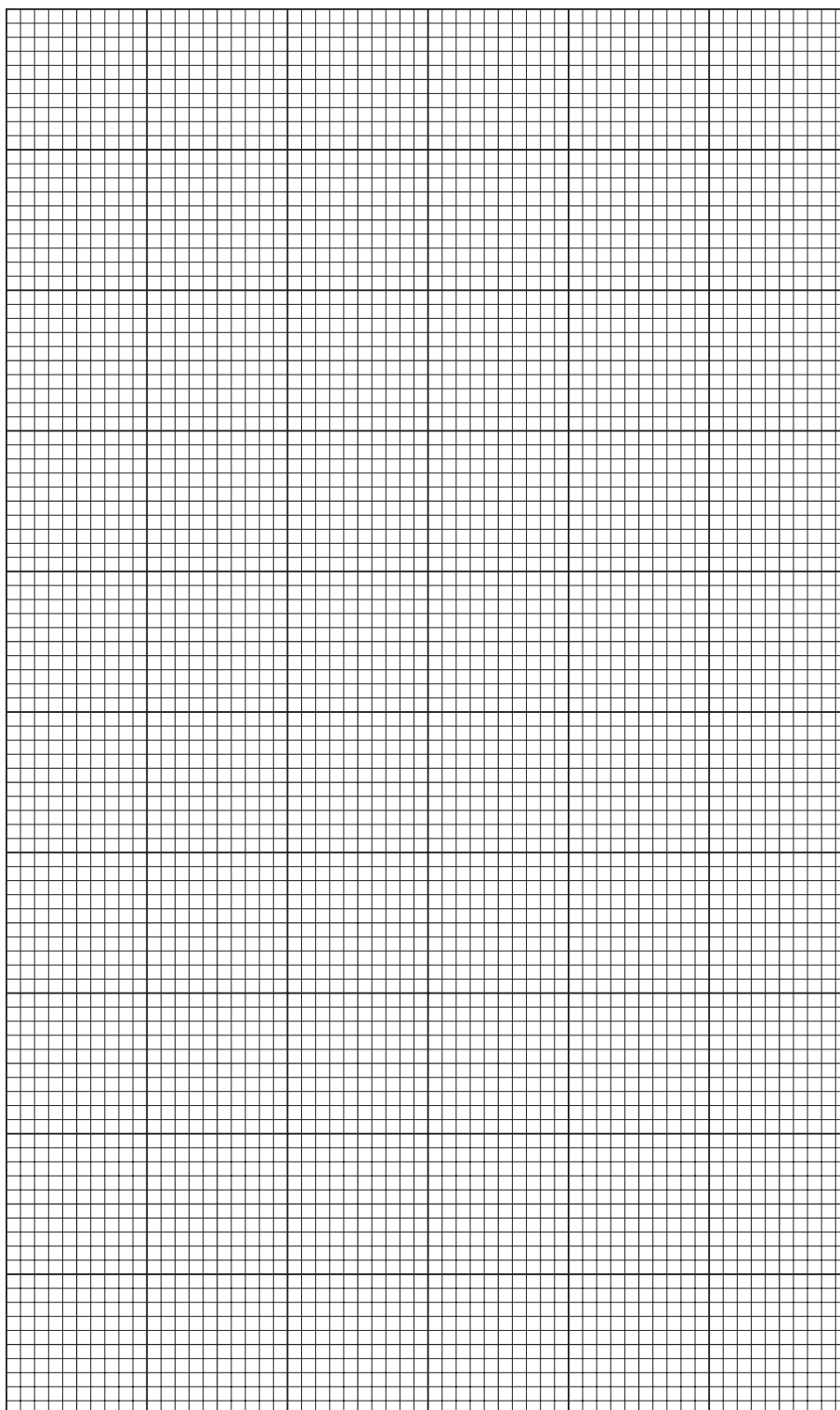

[4]

- (ii) Use your graph to predict the time taken using a concentration of  $1.2 \text{ mol/dm}^3$ .

time taken = .....s

[1]

(d) Use your graph to describe the relationship between the concentration of acid and the **rate** of reaction.

.....  
.....[1]

(e) A student read in a book that 0.1 g of magnesium produces 100 cm<sup>3</sup> of hydrogen gas when reacted with hydrochloric acid. Describe an experiment you would carry out to test this statement. Draw a diagram of the apparatus that you would use.

.....  
.....  
.....  
.....  
.....

[3]



- 2 You are required to find the focal length of the lens provided and then use this value to investigate the type of image produced when an object is placed at different distances from the lens.

- (a) (i) Using plasticine, fix the lens at the 50 cm mark of the metre rule and move the screen, arranged as shown in Fig. 2.1, until a sharp image of an object at the other side of the room, such as a window, is obtained on the screen. Measure and record the distance  $f_1$  between the lens and the screen.

$f_1 = \dots\dots\dots$ mm

- (ii) Place the lens at the 40 cm mark and repeat the experiment. Finally, place the lens at the 30 cm mark and repeat the experiment recording your results in the spaces below.

$f_2 = \dots\dots\dots$ mm       $f_3 = \dots\dots\dots$ mm

Calculate the average value for the focal length,  $F$ , of the lens.

average value for focal length,  $F = \dots\dots\dots$ mm

[3]

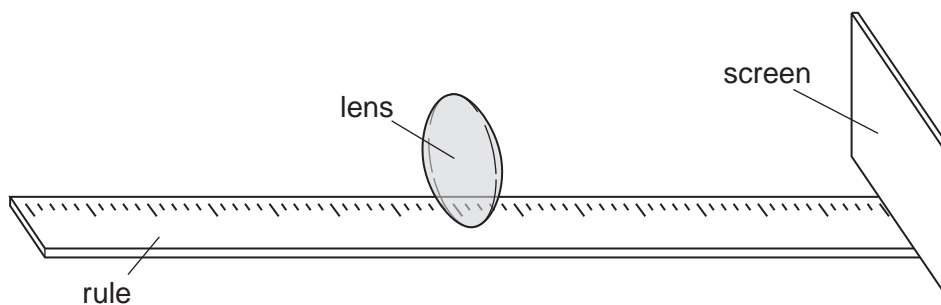

Fig. 2.1

- (b) (i)

- Using plasticine, fix the lens at the 50 cm mark of the metre rule.
- Place a small piece of plasticine on the rule at the point  $F$  mm from the lens on each side. See Fig. 2.2
- Place a small piece of plasticine on the rule at the point  $2F$  mm from the lens on each side. See Fig. 2.2
- Place the lighted candle (the object), on the rule beyond  $2F$  mm. See Fig. 2.2
- Move the screen, on the other side of the lens from the object, to obtain a sharp image of the candle flame on the screen.
- Record in Fig. 2.3 the position of the image, whether it is larger, smaller or the same size as the object, and whether it is upright or inverted.

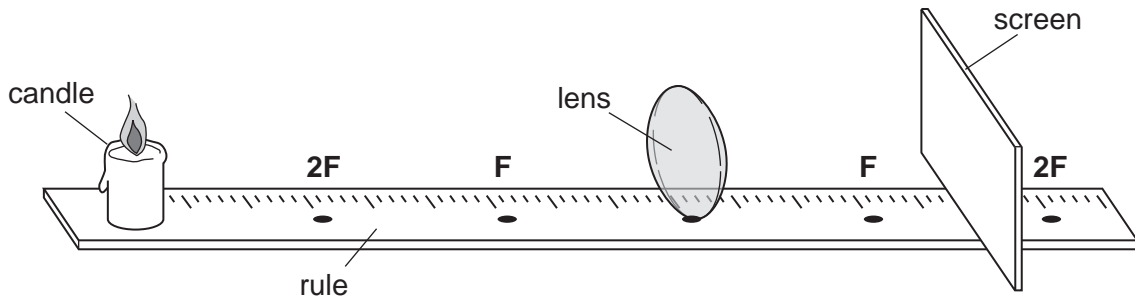

Fig. 2.2

object position	image position	larger, smaller or same size	upright or inverted
beyond 2F			
at 2F			
between 2F and F			

Fig. 2.3

- (ii) Repeat the experiment with the object **at 2F** and then **between 2F and F**. Record your observations in Fig. 2.3 as before. [9]
- (c) You are now required to complete the diagram, Fig. 2.4, as described and make measurements as instructed.

Draw a horizontal line from the top of the vertical line **D** to meet the lens. Label this point on the lens, **E**.

Now draw a straight line from **F<sub>2</sub>** through **E** and beyond.

Draw another straight line from **C** to touch the top of the line **D**. These two straight lines should meet beyond **F<sub>1</sub>**.

Measure and record the vertical distance from the line **AB** to where these two lines meet.

distance = .....mm [3]

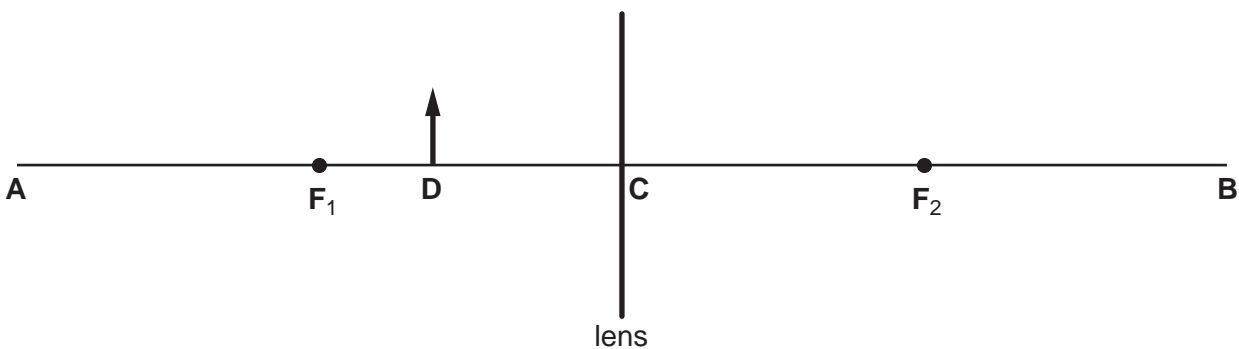

Fig. 2.4

## CHEMISTRY PRACTICAL NOTES

## Test for anions

<i>anion</i>	<i>test</i>	<i>test result</i>
carbonate ( $\text{CO}_3^{2-}$ )	add dilute acid	effervescence, carbon dioxide produced
chloride ( $\text{Cl}^-$ ) [in solution]	acidify with dilute nitric acid, then add aqueous silver nitrate	white ppt.
nitrate ( $\text{NO}_3^-$ ) [in solution]	add aqueous sodium hydroxide, then aluminium foil; warm carefully	ammonia produced
sulphate ( $\text{SO}_4^{2-}$ ) [in solution]	acidify, then add aqueous barium chloride <i>or</i> aqueous barium nitrate	white ppt.

## Test for aqueous cations

<i>cation</i>	<i>effect of aqueous sodium hydroxide</i>	<i>effect of aqueous ammonia</i>
ammonium ( $\text{NH}_4^+$ )	ammonia produced on warming	–
copper(II) ( $\text{Cu}^{2+}$ )	light blue ppt., insoluble in excess	light blue ppt., soluble in excess, giving a dark blue solution
iron(II) ( $\text{Fe}^{2+}$ )	green ppt., insoluble in excess	green ppt., insoluble in excess
iron(III) ( $\text{Fe}^{3+}$ )	red-brown ppt., insoluble in excess	red-brown ppt., insoluble in excess
zinc ( $\text{Zn}^{2+}$ )	white ppt., soluble in excess, giving a colourless solution	white ppt., soluble in excess, giving a colourless solution

## Test for gases

<i>gas</i>	<i>test and test result</i>
ammonia ( $\text{NH}_3$ )	turns damp litmus paper blue
carbon dioxide ( $\text{CO}_2$ )	turns lime water milky
chlorine ( $\text{Cl}_2$ )	bleaches damp litmus paper
hydrogen ( $\text{H}_2$ )	'pops' with a lighted splint
oxygen ( $\text{O}_2$ )	relights a glowing splint