

| | | |
|---------------|------------------|------|
| Centre Number | Candidate Number | Name |
|---------------|------------------|------|

UNIVERSITY OF CAMBRIDGE INTERNATIONAL EXAMINATIONS
International General Certificate of Secondary Education

PHYSICAL SCIENCE

0652/02

Paper 2

October/November 2004

1 hour 15 minutes

Candidates answer on the Question Paper.
No Additional Materials are required.

READ THESE INSTRUCTIONS FIRST

Write your Centre number, candidate number and name on all the work you hand in.
Write in dark blue or black pen in the spaces provided on the Question Paper.
You may use a soft pencil for any diagrams, graphs, tables or rough working.
Do not use staples, paper clips, highlighters, glue or correction fluid.

Answer **all** questions.

The number of marks is given in brackets [] at the end of each question or part question.

A copy of the Periodic Table is printed on page 12.

For Examiner's Use

| | |
|--------------|--|
| 1 | |
| 2 | |
| 3 | |
| 4 | |
| 5 | |
| 6 | |
| 7 | |
| 8 | |
| 9 | |
| 10 | |
| 11 | |
| 12 | |
| 13 | |
| 14 | |
| 15 | |
| Total | |

If you have been given a label, look at the details. If any details are incorrect or missing, please fill in your correct details in the space given at the top of this page.

Stick your personal label here, if provided.

This document consists of **12** printed pages.



- 1 Fig. 1.1 shows a current carrying coil in a magnetic field. There is a force of 5.0 N on each side of the coil acting as shown.

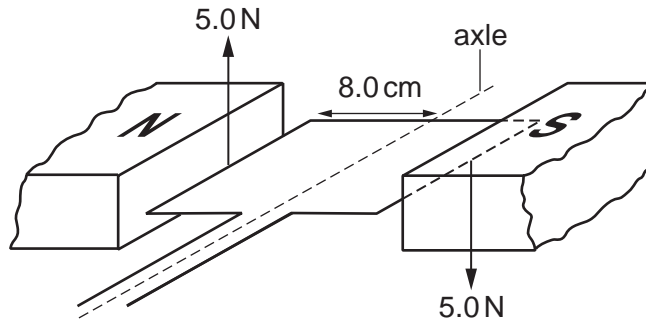

Fig. 1.1

- (a) (i) Calculate the moment about the axle produced by the force on the right hand side of the coil. Show your working and state the unit.

moment =

- (ii) Write down the moment about the axle produced by the force on the left hand side of the coil.

.....

- (iii) Calculate the total moment on the axle.

moment = [5]

- (b) (i) State the effect on the total moment about the axle of increasing the current in the coil.

.....

- (ii) State the effect on the total moment about the axle of decreasing the number of turns of wire in the coil.

.....[2]

- (c) Name a device or a piece of apparatus which relies on the turning effect on a coil in a magnetic field.

.....[1]

2 Using a microscope, the small drops of fat in milk can be seen moving about slowly in a random way.

(a) Name this type of movement. [1]

(b) Use words from the list below to complete the sentences describing this type of movement. You may use each word once, more than once or not at all.

collide combine electrons larger molecules smaller

The of water are moving about quickly. They with the drops of fat. The drops of fat move slowly because they are much than the of water.

[4]

3 Fig. 3.1 shows a hot water system for a house.

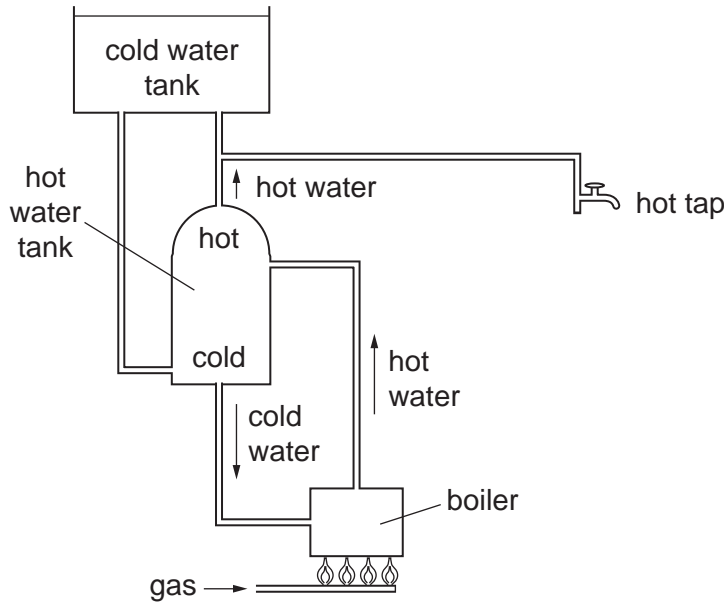

Fig. 3.1

(a) (i) Name the main process by which hot water rises from the boiler to the hot water tank.

.....

(ii) Explain why this process occurs.

.....

.....[3]

(b) (i) Name the main process by which the energy is transferred through the boiler wall to the water.

.....

(ii) Complete the sentences below, which describe the energy changes as the gas is burnt.

When the gas is burnt energy of the gas is converted into

..... energy which raises the temperature of the water. The combustion

process is an change. [4]

(c) Energy is lost from the hot water tank causing the water to cool. Suggest a way in which this loss could be minimised.

.....[1]

4 A student uses paper chromatography to investigate three substances, **X**, **Y** and **Z**.

The result of her experiment in Fig. 4.1 shows three components, **P**, **Q** and **R**.

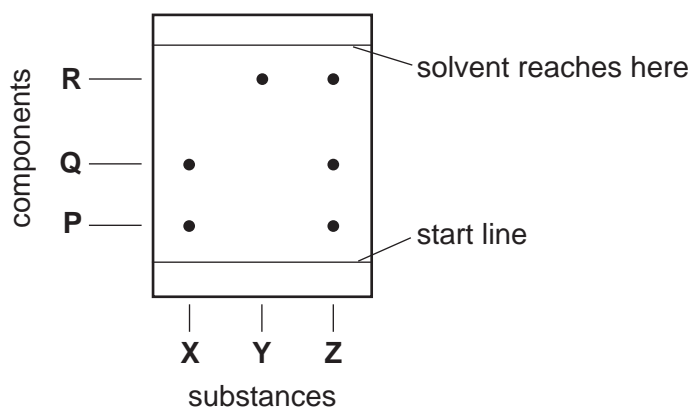

Fig. 4.1

(a) State and explain which substance is a mixture of the other two.

.....
[2]

(b) State and explain which component is most soluble in the solvent.

.....
[2]

5

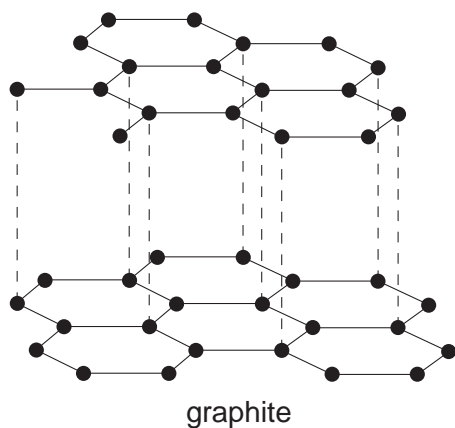

6

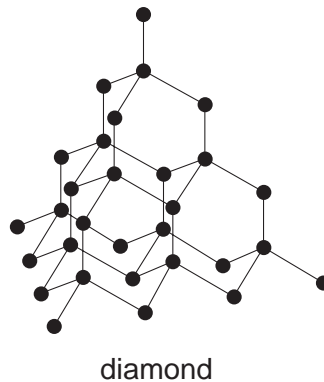

Fig. 5.1

Use the information in Fig. 5.1 to describe the structures of

(i) graphite,

.....
.....
.....[2]

(ii) diamond.

.....
.....
.....[2]

6 (a) (i) Describe how a potassium atom, K, forms a potassium ion.

.....
.....[1]

(ii) Describe how an iodine atom, I, forms an iodide ion.

.....
.....[1]

(b) Hence describe how potassium iodide is formed from potassium and iodine.

.....
.....[2]

7 Fig. 7.1 shows a circuit being used to light two identical bulbs.

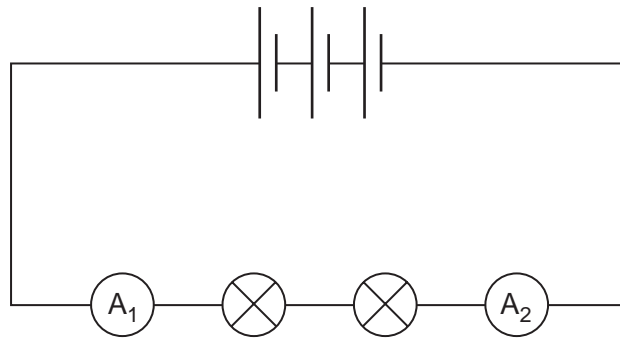

Fig. 7.1

Ammeter A_1 reads 0.75 A and the potential difference across the **two** bulbs is 4.5 V.

- (a) (i) What is the reading on ammeter A_2 ? A
 (ii) Calculate the total resistance in the circuit. Show your working and state the unit.

resistance =

- (iii) What is the resistance of one bulb?

resistance = [5]

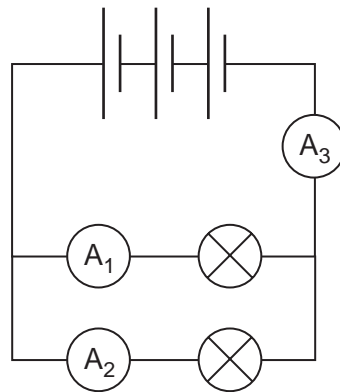

Fig. 7.2

Fig. 7.2 shows another circuit which could be used to light the two bulbs.

Both ammeter A_1 and ammeter A_2 read 1.5 A.

- (b) What would ammeter A_3 read? A [1]

- (c) Explain whether the bulbs would be brighter in the circuit in Fig. 7.1 or Fig. 7.2.

.....

..... [2]

8 A saturated hydrocarbon gas is given off from decaying rubbish.

(a) One molecule of this hydrocarbon contains one carbon atom and four hydrogen atoms.

(i) Write the molecular formula of this hydrocarbon. [1]

(ii) Use the information in the Periodic Table on page 12 to calculate the relative molecular mass, M_r , of this hydrocarbon.

$M_r = \dots\dots\dots$ [1]

(b) This gas burns completely in air to form carbon dioxide and water.

hydrocarbon gas + oxygen \rightarrow carbon dioxide + water

Construct a balanced chemical equation for this reaction.

.....[2]

9 (a) Copper oxide heated in hydrogen forms copper and water.

Use this example to explain the meaning of *reduction*.

.....
.....[2]

(b) State two properties of copper that show this metal is a **transition** element.

1

2 [2]

10 A student prepares magnesium sulphate by adding pieces of magnesium to dilute sulphuric acid until there is excess magnesium and the reaction stops.

(a) Describe how the student can obtain crystals of magnesium sulphate from the mixture of aqueous magnesium sulphate and excess magnesium.

.....
.....
.....[2]

(b) Hydrogen is also produced in the first experiment.

Describe a test to identify this gas.

test

result [2]

11 Fig. 11.1 shows a beam of light being shone on a pond.

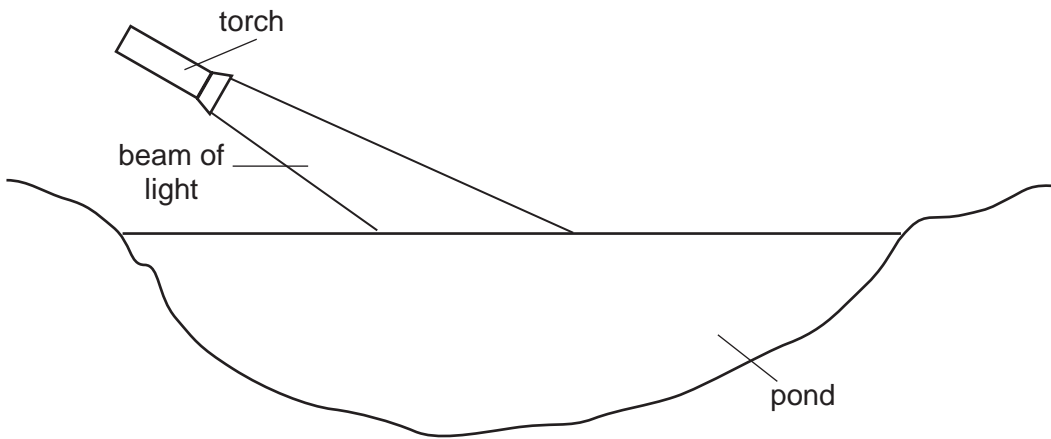

Fig. 11.1

- (a) (i) Complete the two rays, which mark the edges of the beam of light, to show the path of the beam after it enters the water.
- (ii) For one of the rays, mark the angle of incidence and label it *i*.
- (iii) Name the effect that this experiment demonstrates.

.....

[4]

Fig. 11.2 shows the front of a police car.



Fig. 11.2

- (b) Explain, using appropriate scientific terms, why the car has the mirror writing on the front.

.....

[2]

12 (a) A student adds aqueous bromine to a colourless solution of potassium iodide. The solution changes colour, showing a reaction has occurred.

(i) State the product of this reaction that causes the change of colour.

..... [1]

(ii) In terms of the reactivity of the halogens, explain why there is a reaction in this experiment.

.....
.....[1]

(b) Another student adds aqueous bromine to a colourless solution of potassium chloride. There is no reaction.

In terms of the reactivity of the halogens, explain why there is no reaction in this experiment.

.....
.....[1]

13 State and explain the purpose of the two main steps in the purification of the water supply for domestic purposes.

step 1

.....
.....[2]

step 2

.....
.....[2]

- 14 (a) Draw the structures of ethane, C_2H_6 , and ethene, C_2H_4 . Show all the atoms and all the bonds.

ethane

ethene

[2]

- (b) Explain why alkenes, such as ethene, do react with steam whereas alkanes, such as ethane, do not react with steam.

.....
 [2]

- 15 The isotope $^{90}_{38}\text{Sr}$ is a radioactive isotope which emits β -particles.

- (a) (i) Explain what is meant by the term *isotope*.

.....
 [2]

- (ii) Explain what a β -particle is.

.....
 [2]

- (b) (i) Complete the table in Fig. 15.1 which describes the make up of a neutral atom of $^{90}_{38}\text{Sr}$.

| | |
|---------------------|--|
| Number of protons | |
| Number of neutrons | |
| Number of electrons | |

Fig. 15.1

- (ii) Which type of particle, listed in Fig. 15.1, is **not** found in the nucleus of an atom?

..... [4]

- (c) Complete the equation below which describes the decay of $^{90}_{38}\text{Sr}$.

