

Candidate
Number

Centre Number

Candidate Name _____

--	--

**International General Certificate of Secondary Education
CAMBRIDGE INTERNATIONAL EXAMINATIONS**

PHYSICAL SCIENCE

0652/3

PAPER 3

OCTOBER/NOVEMBER SESSION 2002

1 hour 15 minutes

Candidates answer on the question paper.
No additional materials are required.

TIME 1 hour 15 minutes

INSTRUCTIONS TO CANDIDATES

Write your name, Centre number and candidate number in the spaces at the top of this page.

Answer **all** questions.

Write your answers in the spaces provided on the question paper.

INFORMATION FOR CANDIDATES

The number of marks is given in brackets [] at the end of each question or part question.

A copy of the Periodic Table is printed on page 16.

FOR EXAMINER'S USE	
1	
2	
3	
4	
5	
6	
7	
8	
9	
10	
TOTAL	

This question paper consists of 15 printed pages and 1 blank page.

- 1 The table, Fig. 1.1, shows some of the properties of the elements in Group V of the Periodic Table.

element	density in g/cm ³	melting point in K	type of structure	type of oxide
nitrogen	0.0012	63	covalent molecule	acidic
phosphorus	2.2	317	covalent molecule	
arsenic	5.7	1090	metallic	amphoteric
antimony		905		amphoteric
bismuth	9.8	545	metallic	amphoteric

Fig.1.1

- (a) Complete the table by suggesting the density of antimony, the type of structure for antimony and the type of oxide formed by phosphorus. [3]
- (b) Suggest a reason why the melting points of the elements do not show a steady trend.

.....

.....

.....

..... [2]

- 2 Fig. 2.1 shows a force of 80 N applied to the pedal of a bicycle. The force is applied at a distance of 30 cm from the axis about which the gear wheel turns.

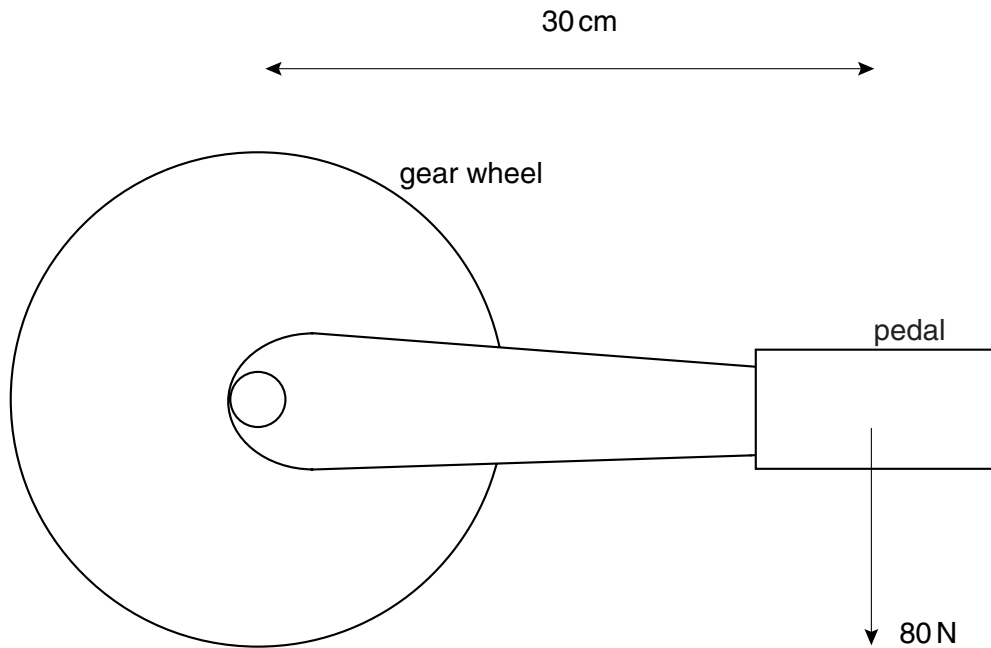

Fig. 2.1

- (a) Calculate the moment of the force about the axis.

Write down the equation that you use and show your working.

moment of the force = [3]

- (b) (i) Explain what is meant by *power*.

.....
 [1]

- (ii) Suggest why the power input to the gear wheel changes with the position of the pedal.

.....

 [2]

3 Iron is extracted from the ore haematite, Fe_2O_3 , in a blast furnace by reduction with carbon. The carbon is put into the furnace in the form of coke.

(a) (i) Use the Periodic Table on page 16 of this paper to deduce the charge on an oxide ion.

charge on oxide ion [1]

(ii) Use the answer to (i) and the formula of haematite to find the charge on the ion of iron present in haematite.

charge on iron ion [1]

(iii) Write down the formula of the chloride which would be formed using the ion of iron in (ii).

formula of chloride [1]

(iv) Iron forms another chloride named iron(II) chloride. Describe a simple chemical test to distinguish between a solution of the chloride of iron in (iii) and a solution of iron(II) chloride.

Test

.....

Result with iron(II) chloride

.....

Result with chloride of iron in (iii)

..... [3]

(b) Write a balanced equation for the reduction of haematite, Fe_2O_3 , by carbon.

..... [2]

(c) (i) What other solid is mixed with the coke and iron ore in a blast furnace?

.....

(ii) What is the reason for adding this substance to the furnace?

.....

.....

..... [2]

BLANK PAGE

- 4 Fig. 4.1 shows the fruit of a plant. Its structure allows the fruit to fall slowly so that several fruits can be scattered by horizontal breezes.

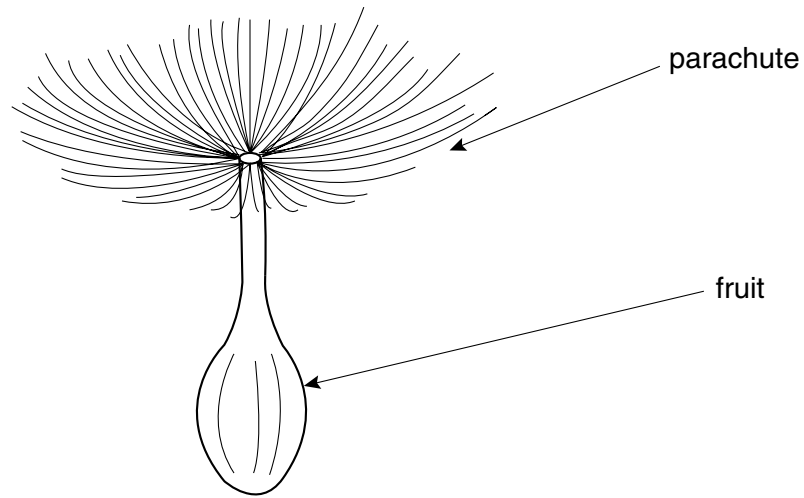

Fig. 4.1

The mass of the fruit and parachute of tiny hairs is 1.2 g.

- (a) (i) Calculate the weight of the fruit and parachute.
[$g = 10 \text{ N/kg}$]

weight = [2]

- (ii) When the fruit falls at a constant vertical speed what is the magnitude of the upward force acting on it?

magnitude of upward force = [1]

- (iii) The fruit falls at 0.2 m/s. Calculate the kinetic energy of the fruit.

Write down the equation that you use and show your working.

kinetic energy = [3]

(b) The fruit falls to the ground from a height of 0.3 m in 1.5 s at a constant vertical speed.

(i) Calculate the gravitational potential energy of the fruit before it falls.

Show your working.

gravitational potential energy = [2]

(ii) On the grid of Fig. 4.2 show how the gravitational potential energy changes over the 1.5 s period. Mark numbers and units on the vertical axis.

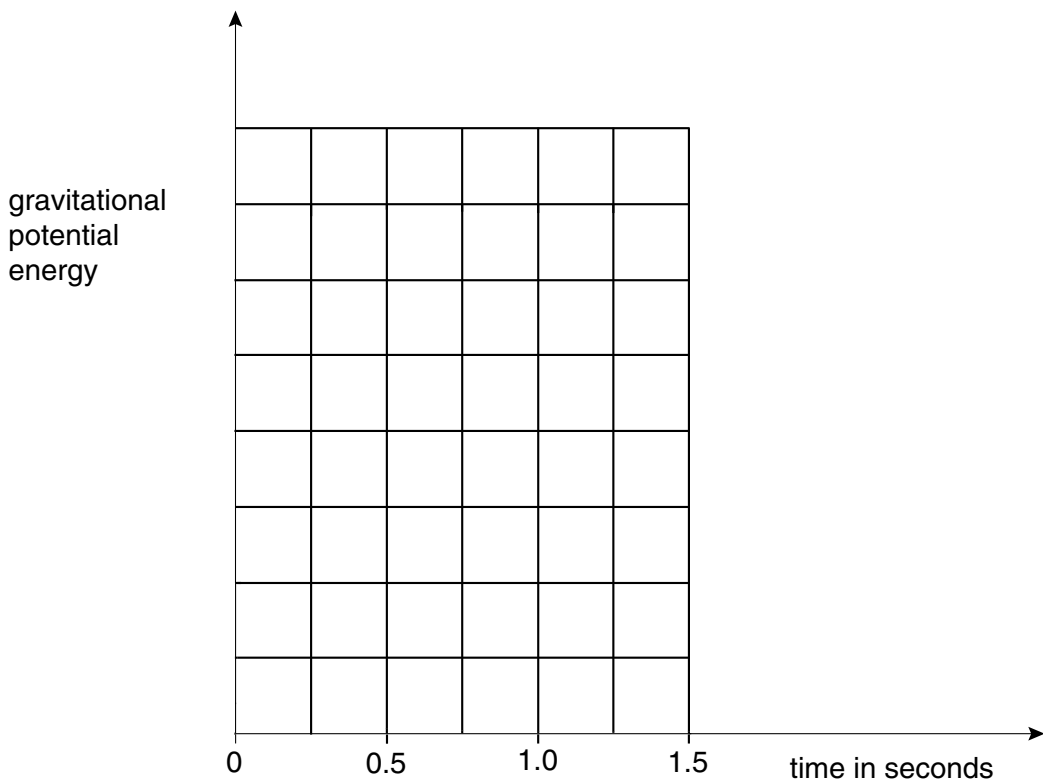

Fig. 4.2

[2]

(iii) Explain the energy change that occurs as the fruit falls through the air.

.....

.....

..... [2]

- 5** The soluble salt magnesium sulphate can be prepared by reacting the insoluble solid magnesium oxide with sulphuric acid. The reaction is carried out by adding the solid to warm dilute sulphuric acid until no more solid reacts. The salt is isolated by filtering and slowly evaporating the solution until crystals of the hydrated salt are produced.

(a) Explain why it is necessary to filter the solution before evaporating it.

.....
..... [1]

(b) Calcium sulphate is an insoluble salt, but calcium nitrate is soluble.

(i) Explain why the method described above cannot be used to prepare calcium sulphate crystals from calcium oxide.

.....
..... [1]

(ii) Suggest a suitable method for preparing calcium sulphate using sulphuric acid as one of the starting materials.

.....
.....
.....
..... [3]

- (c) The equation for the reaction between magnesium oxide and sulphuric acid may be written:

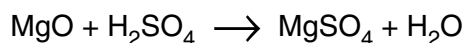

- (i) Calculate the relative molecular mass, M_r , for magnesium oxide.

You should use the Periodic Table on page 16 of this paper to help you answer this question.

M_r of magnesium oxide = [1]

- (ii) Calculate the number of moles in 8 g of magnesium oxide.

number of moles of magnesium oxide = [1]

- (iii) Hence calculate the volume of sulphuric acid of concentration 2 mol/dm^3 which will react with 8 g of magnesium oxide.

Show your working.

volume of sulphuric acid = [3]

- 6 Fig. 6.1 shows a section through a ripple tank. The dipper is made to bounce up and down by the rotation of a motor mounted on a pair of rubber bands. For each rotation of the motor one new wave is sent out.

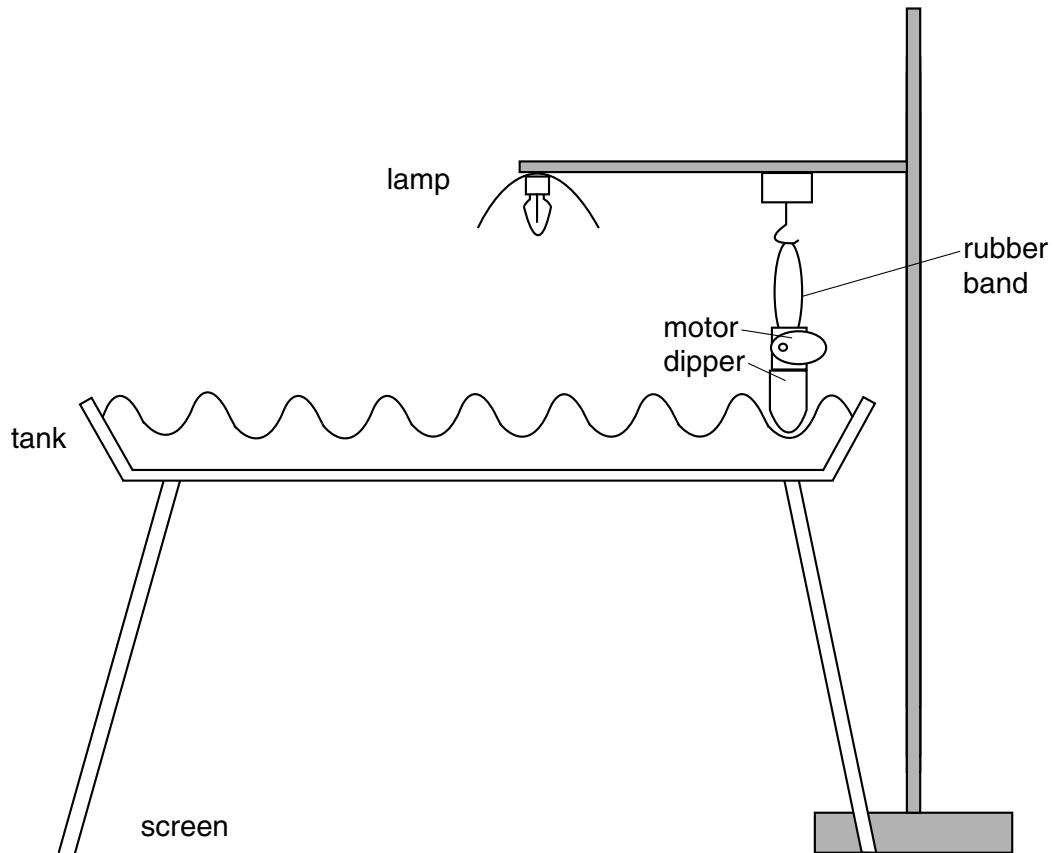

Fig. 6.1

- (a) A series of alternate bright and dark lines can be seen on the screen below the tank. Suggest how this pattern is formed.

.....

.....

..... [2]

(b) Explain how you would measure the wavelength of the wave.

.....
.....
.....
.....
.....
..... [4]

(c) The waves travel at a speed of 2.5 cm/s and their wavelength is 4.2 cm.

Calculate how many times the motor must rotate in a minute.

Write down the equation that you use and show your working.

number of rotations per minute = [4]

7 Ethanol and methanol are members of the same homologous series of organic compounds. Ethanol, C_2H_5OH , may be produced by the addition reaction between ethene, C_2H_4 , and steam.

(a) (i) Write down the formula of methanol. [1]

(ii) Draw a dot-and-cross diagram to show the bonding in methanol.

You need only show the outer shell electrons in each atom.

[2]

(iii) Explain why ethanol and methanol are considered to be members of the same homologous series.

.....

..... [1]

(b) (i) Write an equation for the addition reaction between ethene and steam.

..... [2]

(ii) State two of the conditions necessary for this reaction to occur.

1.

2. [2]

(c) State one industrial method of obtaining the ethene used to make ethanol.

.....

..... [1]

- 8 Fig. 8.1 shows a circuit in which an ammeter and voltmeter are included.

Calculate the ammeter and voltmeter readings in this circuit. You can only gain full marks for this question by writing down any equations that you use and showing your working.

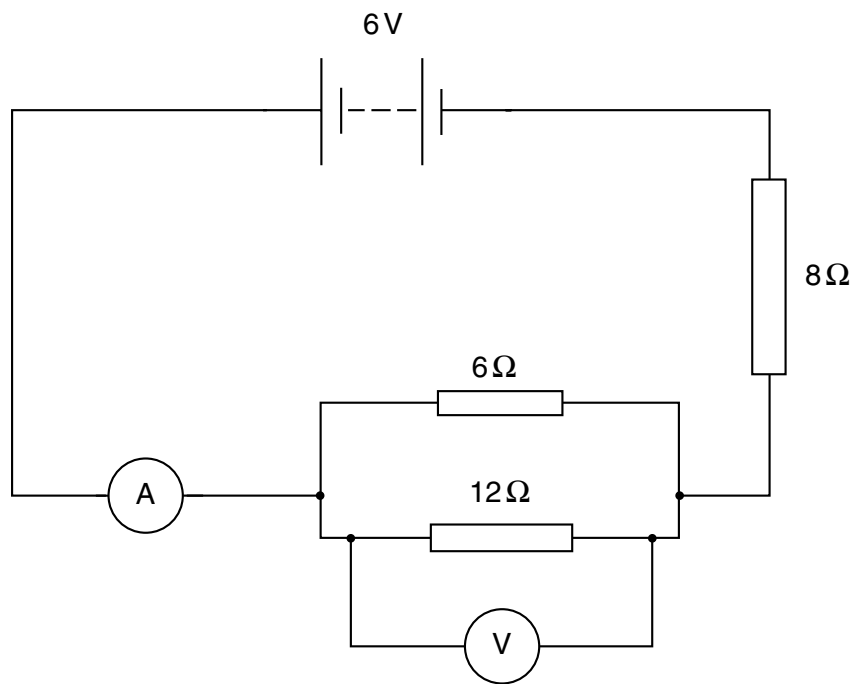

Fig. 8.1

ammeter reading = A

voltmeter reading = V

[6]

9 Aluminium is a very reactive metal which is protected from corrosion by a layer of aluminium oxide. This oxide has amphoteric properties.

(a) Explain why the oxide layer formed on aluminium protects it from corrosion but iron is not protected by the formation of a layer of rust.

.....
.....
..... [2]

(b) Oven cleaners often contain sodium hydroxide to help remove fat. Explain why such a cleaner should not be used on aluminium utensils.

.....
.....
..... [2]

(c) Aluminium is not extracted from its ore by reduction with carbon.

(i) Name the main ore of aluminium. [1]

(ii) Suggest a reason why aluminium cannot be extracted by reduction with carbon.

.....
..... [1]

- 10 (a) Complete the following sentences about transformers using **only** words from the list. Each word may be used once, more than once or not at all.

changing **constant** **current** **direct** **induction**
output **primary** **resistance** **voltage** **waves**

Transformers work using the principle of electromagnetic

A current in the coil generates a voltage across the secondary coil. In a step-up transformer the output is greater than the input voltage. [4]

- (b) A step-down transformer with a primary coil of 500 turns is used to transform 120 V to 6 V.

Calculate the number of turns on the secondary coil.

Show all your working.

number of turns = [2]

DATA SHEET
The Periodic Table of the Elements

		Group																					
I	II	III	IV	V	VI	VII	O																
7 Li Lithium 3	9 Be Beryllium 4	<table border="1" style="width: 100%; border-collapse: collapse; text-align: center;"> <tr> <td>1 H Hydrogen 1</td> <td colspan="10"></td> </tr> </table>										1 H Hydrogen 1											4 He Helium 2
1 H Hydrogen 1																							
23 Na Sodium 11	24 Mg Magnesium 12	11 B Boron 5	12 C Carbon 6	14 N Nitrogen 7	16 O Oxygen 8	19 F Fluorine 9	20 Ne Neon 10	27 Al Aluminium 13	28 Si Silicon 14	31 P Phosphorus 15	32 S Sulphur 16	35.5 Cl Chlorine 17	40 Ar Argon 18										
39 K Potassium 19	40 Ca Calcium 20	51 V Vanadium 23	48 Ti Titanium 22	59 Co Cobalt 27	56 Fe Iron 26	59 Ni Nickel 28	64 Cu Copper 29	65 Zn Zinc 30	70 Ga Gallium 31	73 Ge Germanium 32	75 As Arsenic 33	79 Se Selenium 34	84 Kr Krypton 36										
85 Rb Rubidium 37	88 Sr Strontium 38	93 Nb Niobium 41	91 Zr Zirconium 40	103 Rh Rhodium 45	101 Ru Ruthenium 44	106 Pd Palladium 46	108 Ag Silver 47	112 Cd Cadmium 48	115 In Indium 49	119 Sn Tin 50	122 Sb Antimony 51	128 Te Tellurium 52	131 Xe Xenon 54										
133 Cs Caesium 55	137 Ba Barium 56	181 Ta Tantalum 73	178 Hf Hafnium 72	192 Ir Iridium 77	190 Os Osmium 76	195 Pt Platinum 78	197 Au Gold 79	201 Hg Mercury 80	204 Tl Thallium 81	207 Pb Lead 82	209 Bi Bismuth 83	210 Po Polonium 84	222 Rn Radon 86										
87 Fr Francium	88 Ra Radium	226 Ac Actinium	†																				
		140 Ce Cerium 58	141 Pr Praseodymium 59	150 Sm Samarium 62	152 Eu Europium 63	157 Gd Gadolinium 64	162 Dy Dysprosium 66	165 Ho Holmium 67	167 Er Erbium 68	169 Tm Thulium 69	173 Yb Ytterbium 70	175 Lu Lutetium 71											
		232 Th Thorium 90	238 U Uranium 92	94 Pu Plutonium 94	95 Am Americium 95	96 Cm Curium 96	97 Bk Berkelium 97	99 Es Einsteinium 99	100 Fm Fermium 100	101 Md Mendelevium 101	102 No Nobelium 102	103 Lr Lawrencium 103											

*58-71 Lanthanoid series
†90-103 Actinoid series

	a	= relative atomic mass
	X	= atomic symbol
	b	= proton (atomic) number

The volume of one mole of any gas is 24 dm³ at room temperature and pressure (r.t.p.).