



**Cambridge International Examinations**  
Cambridge International General Certificate of Secondary Education

CANDIDATE  
NAME

CENTRE  
NUMBER

--	--	--	--	--

CANDIDATE  
NUMBER

--	--	--	--



**CAMBRIDGE INTERNATIONAL MATHEMATICS**

**0607/12**

Paper 1 (Core)

**October/November 2018**

**45 minutes**

Candidates answer on the Question Paper.

Additional Materials: Geometrical Instruments

**READ THESE INSTRUCTIONS FIRST**

Write your Centre number, candidate number and name on all the work you hand in.

Write in dark blue or black pen.

Do not use staples, paper clips, glue or correction fluid.

You may use an HB pencil for any diagrams or graphs.

**DO NOT WRITE IN ANY BARCODES.**

Answer **all** the questions.

**CALCULATORS MUST NOT BE USED IN THIS PAPER.**

All answers should be given in their simplest form.

You must show all the relevant working to gain full marks and you will be given marks for correct methods even if your answer is incorrect.

The number of marks is given in brackets [ ] at the end of each question or part question.

The total number of marks for this paper is 40.

This document consists of **8** printed pages.

**Formula List**

Area,  $A$ , of triangle, base  $b$ , height  $h$ .  $A = \frac{1}{2}bh$

Area,  $A$ , of circle, radius  $r$ .  $A = \pi r^2$

Circumference,  $C$ , of circle, radius  $r$ .  $C = 2\pi r$

Curved surface area,  $A$ , of cylinder of radius  $r$ , height  $h$ .  $A = 2\pi rh$

Curved surface area,  $A$ , of cone of radius  $r$ , sloping edge  $l$ .  $A = \pi rl$

Curved surface area,  $A$ , of sphere of radius  $r$ .  $A = 4\pi r^2$

Volume,  $V$ , of prism, cross-sectional area  $A$ , length  $l$ .  $V = Al$

Volume,  $V$ , of pyramid, base area  $A$ , height  $h$ .  $V = \frac{1}{3}Ah$

Volume,  $V$ , of cylinder of radius  $r$ , height  $h$ .  $V = \pi r^2 h$

Volume,  $V$ , of cone of radius  $r$ , height  $h$ .  $V = \frac{1}{3}\pi r^2 h$

Volume,  $V$ , of sphere of radius  $r$ .  $V = \frac{4}{3}\pi r^3$

Answer **all** the questions.

- 1 Write the number 51 025 in words.

..... [1]

- 2 Write down two factors of 12.

..... [1]

- 3 Work out.

$$7 + 14 \div 7 - 3$$

..... [1]

- 4 Work out 5% of 100.

..... [1]

- 5 Paulo and his sister share 35 sweets in the ratio 4 : 3.  
Paulo keeps the larger share.

How many sweets does Paulo keep?

..... [2]

- 6

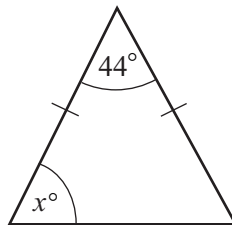

NOT TO  
SCALE

Find the value of  $x$ .

$x =$  ..... [2]

7

continuous	cumulative	discrete	random
------------	------------	----------	--------

Wendi is collecting data on apples.

Which of the words in the box above describes the following type of data.

(a) The number of apples on a tree.

..... [1]

(b) The weight of an apple.

..... [1]

8 Here are the test scores of five students.

13 16 14 19 13

(a) Write down the mode.

..... [1]

(b) Work out the range.

..... [1]

(c) Work out the mean.

..... [2]

9 A biased die is rolled 200 times and the number on the top face is recorded.

The results are shown in the table.

Number on the top face	1	2	3	4	5	6
Frequency	21	26	19	84	27	23

(a) Write down the relative frequency of rolling a 2.

..... [1]

(b) The die is rolled 1000 times.

Work out an estimate of the number of times the top face shows 4.

..... [2]

10 Complete the statement.

A quadrilateral with exactly one pair of parallel sides is called a ..... [1]

11

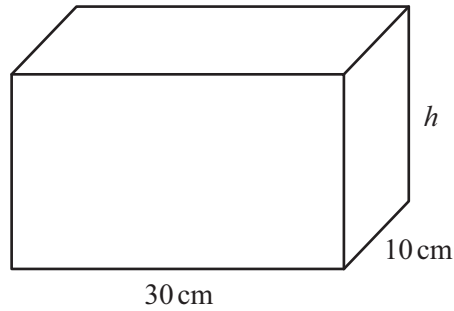

NOT TO SCALE

The volume of this cuboid is  $6000 \text{ cm}^3$ .  
The length of the cuboid is 30 cm and the width of the cuboid is 10 cm.

Find  $h$ , the height of the cuboid.

..... cm [2]

12

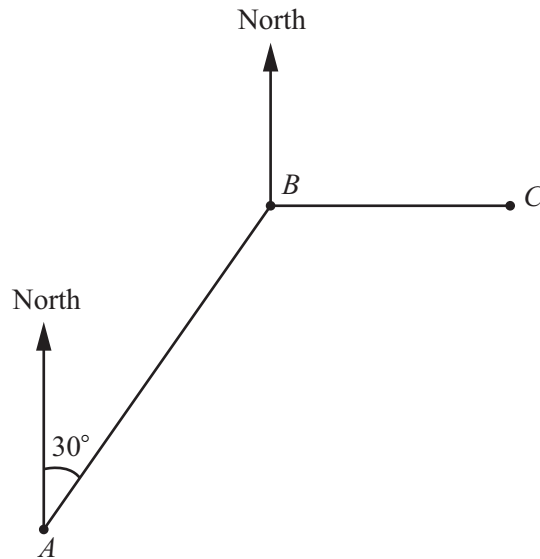

NOT TO SCALE

Alex starts from point  $A$  and walks on a bearing of  $030^\circ$  to point  $B$ . He then walks East to point  $C$ .

Find the bearing of

(a)  $B$  from  $C$ ,

..... [1]

(b)  $A$  from  $B$ .

..... [2]

- 13 Find the highest common factor (HCF) of 12 and 30.

..... [1]

- 14 Write 134.6 in standard form.

..... [1]

- 15 The  $n$ th term of a sequence is  $n^2 - 3$ .

Write down the first three terms.

..... , ..... , ..... [2]

- 16 Factorise.

$$x^2 - 5x$$

..... [1]

- 17 A line has equation  $3x + 2y = 6$ .

Write the equation of this line in the form  $y = mx + c$ .

$y =$  ..... [2]

18  $U = \{x \mid x \text{ is an integer and } 1 \leq x < 5\}$   
 $A' = \{2, 4\}$

(a) Write down the elements of the universal set.

{ ..... } [1]

(b) Write down the elements of the set  $A$ .

{ ..... } [1]

19

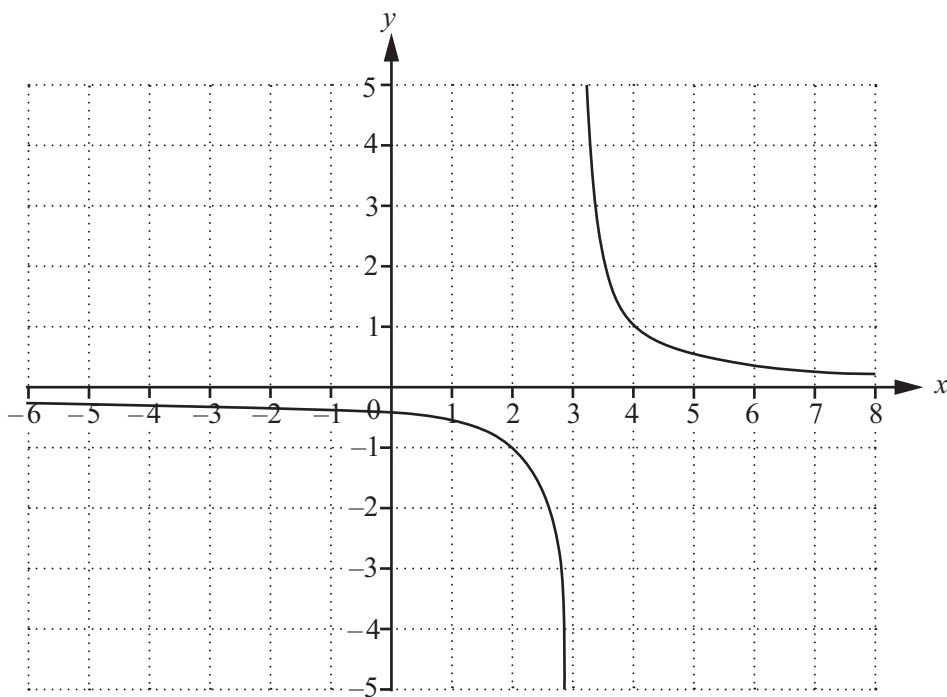

The diagram shows the graph of  $y = f(x)$ .

Write down the equations of the two asymptotes.

.....  
 ..... [2]

20 Complete the statement.

The graph of  $y = g(x)$  is translated by the vector  $\begin{pmatrix} 2 \\ 0 \end{pmatrix}$  onto the graph of  $y = \dots$  [1]

**Questions 21 and 22 are printed on the next page.**

21

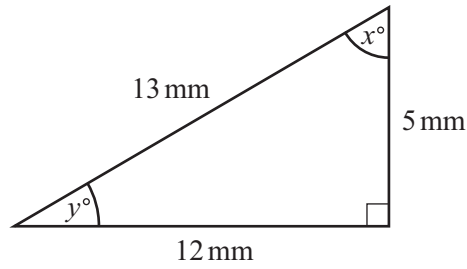

NOT TO SCALE

Write down the value of

(a)  $\sin x^\circ$ ,

..... [1]

(b)  $\tan y^\circ$ .

..... [1]

22

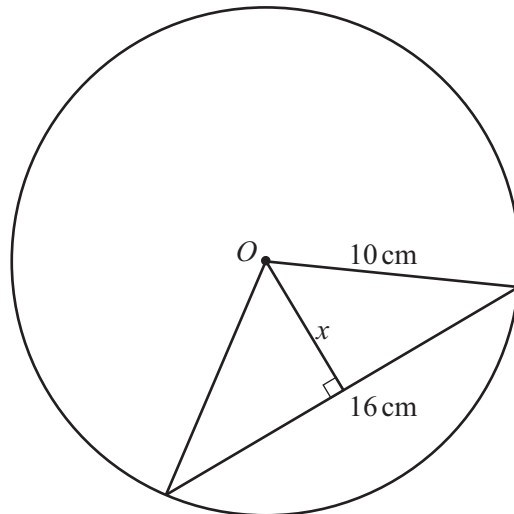

NOT TO SCALE

The diagram shows a chord of length 16 cm inside a circle centre  $O$ , radius 10 cm.

Work out the length  $x$ .

..... cm [3]

Permission to reproduce items where third-party owned material protected by copyright is included has been sought and cleared where possible. Every reasonable effort has been made by the publisher (UCLES) to trace copyright holders, but if any items requiring clearance have unwittingly been included, the publisher will be pleased to make amends at the earliest possible opportunity.

To avoid the issue of disclosure of answer-related information to candidates, all copyright acknowledgements are reproduced online in the Cambridge International Examinations Copyright Acknowledgements Booklet. This is produced for each series of examinations and is freely available to download at [www.cie.org.uk](http://www.cie.org.uk) after the live examination series.

Cambridge International Examinations is part of the Cambridge Assessment Group. Cambridge Assessment is the brand name of University of Cambridge Local Examinations Syndicate (UCLES), which is itself a department of the University of Cambridge.