

- 1 On Monday the temperature was -3°C .
On Tuesday the temperature fell by 5°C .

Write down the temperature on Tuesday.

Answer $^{\circ}\text{C}$ [1]

- 2 Write 0.00387 in standard form.

Answer [1]

3

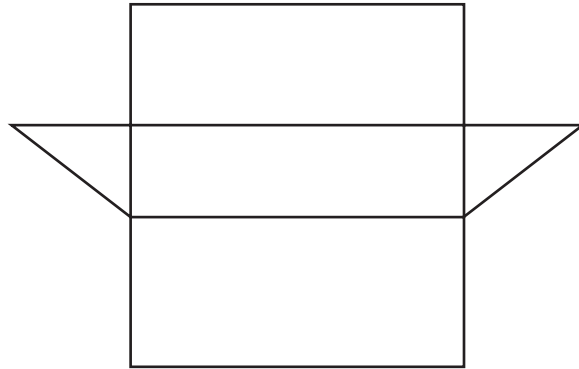

The diagram is an accurate net for a solid shape.

Write down the geometrical name for this solid shape.

Answer [1]

- 4 On a map, a straight section of a canal is 3.5 cm long.
The scale of the map is 1 cm to 5 km.

Calculate the actual length of this straight section.

Answer km [1]

5 Sophie invests \$450 at a rate of 1.5% per year **simple** interest.

Calculate the interest she earns after 8 years.

*For
Examiner's
Use*

Answer \$ [2]

6

A •

• B

Using a straight edge and compasses only, construct the locus of points which are equidistant from point *A* and from point *B*.

Show clearly all your construction arcs.

[2]

- 7 A box is 12 cm high, correct to the nearest centimetre.

Complete the statement about the height, h cm, of the box.

Answer $\leq h <$ [2]

- 8 The metal used to make a coin is a mixture of steel and copper.

The ratio mass of steel : mass of copper is 108 : 7.

The coin has a total mass of 230 milligrams.

Calculate the mass of copper in this coin.

Answer milligrams [2]

- 9

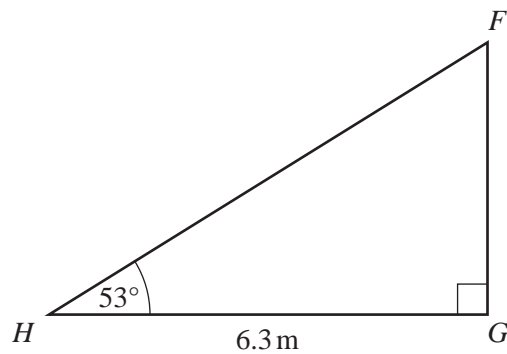

NOT TO
SCALE

Calculate the length FG .

Answer m [2]

10 Use your calculator to find the value of $\sqrt{25.63}$.

Write down your answer

(a) as it appears on your calculator,

Answer(a) [1]

(b) correct to 4 significant figures.

Answer(b) [1]

11 (a)

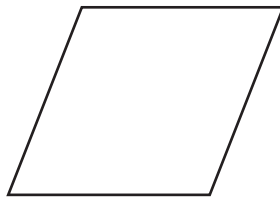

The diagram shows a rhombus.

Draw all the lines of symmetry.

[2]

(b)

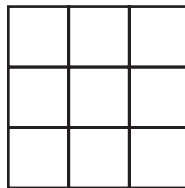

Shade **two** squares in the diagram above so that the figure has **one** line of symmetry and **no** rotational symmetry. [1]

12 Solve the simultaneous equations.

$$\begin{aligned} 3x + y &= 18 \\ 4x - 2y &= 34 \end{aligned}$$

Answer $x =$

$y =$ [3]

13

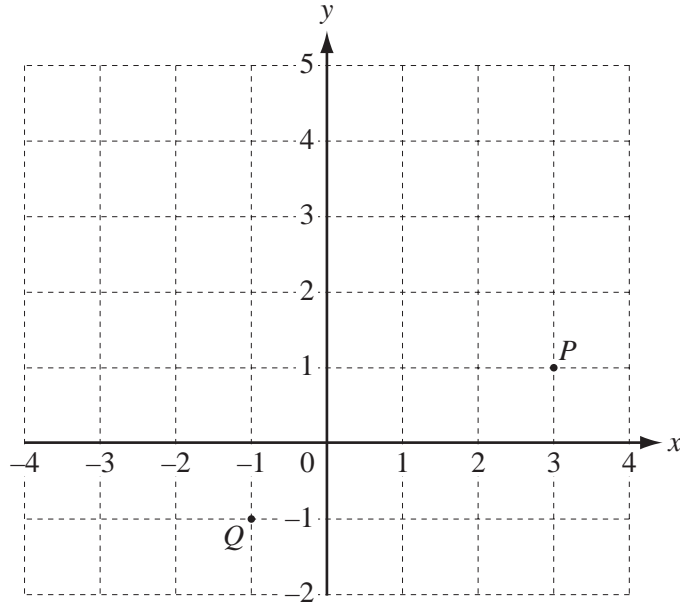
For
Examiner's
Use

The points $P(3, 1)$ and $Q(-1, -1)$ are marked on the grid.

(a) Write down the vector \vec{QP} .

$$\text{Answer(a)} \quad \vec{QP} = \begin{pmatrix} \quad \\ \quad \end{pmatrix} \quad [1]$$

(b) R and S are two more points.

$$\vec{PR} = \begin{pmatrix} -2 \\ 1 \end{pmatrix} \quad \text{and} \quad \vec{PS} = 3 \vec{PR}.$$

(i) Write down the vector \vec{PS} .

$$\text{Answer(b)(i)} \quad \vec{PS} = \begin{pmatrix} \quad \\ \quad \end{pmatrix} \quad [1]$$

(ii) Mark the point S on the grid. [1]

14 Simplify the following.

(a) 8^0

Answer(a) [1]

(b) $(x^5)^2$

Answer(b) [1]

(c) $p^{-3} \div p^4$

Answer(c) [1]

15 A tourist changes \$900 to euros (€) when the exchange rate is €1 = \$1.356.

Calculate the amount he receives.

Give your answer correct to 2 decimal places.

Answer € [3]

- 16 (a) Write down all the common factors of 30 and 42.

Answer(a) [2]

- (b) Write down the smallest number which is a multiple of both 12 and 18.

Answer(b) [2]

- 17 Simon has ten cards, numbered 1 to 10.
He chooses a card at random.

Write down the probability that the number on the card is

- (a) 8,

Answer(a) [1]

- (b) 12,

Answer(b) [1]

- (c) an odd number,

Answer(c) [1]

- (d) not a multiple of 3.

Answer(d) [1]

18

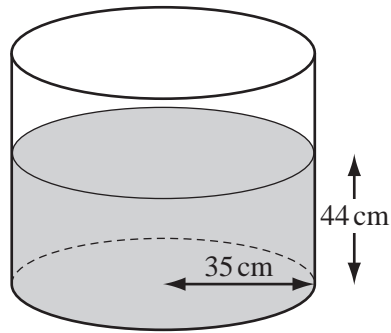
NOT TO
SCALEFor
Examiner's
Use

A cylindrical tank, with radius 35 cm, is filled with water to a depth of 44 cm.

- (a) Calculate the area of the base of the tank.

Answer(a) cm^2 [2]

- (b) Calculate the volume of water in the tank.

Answer(b) cm^3 [1]

- (c) Change your answer to **part (b)** into litres.

Answer(c) litres [1]

19 In this question, **you must show all the steps in your working.**

Without using a calculator, find the value of

(a) $1\frac{1}{3} \div 2\frac{4}{5}$,

Answer(a) [3]

(b) $\frac{13}{15} + \frac{3}{5}$.

Give your answer as a mixed number.

Answer(b) [3]

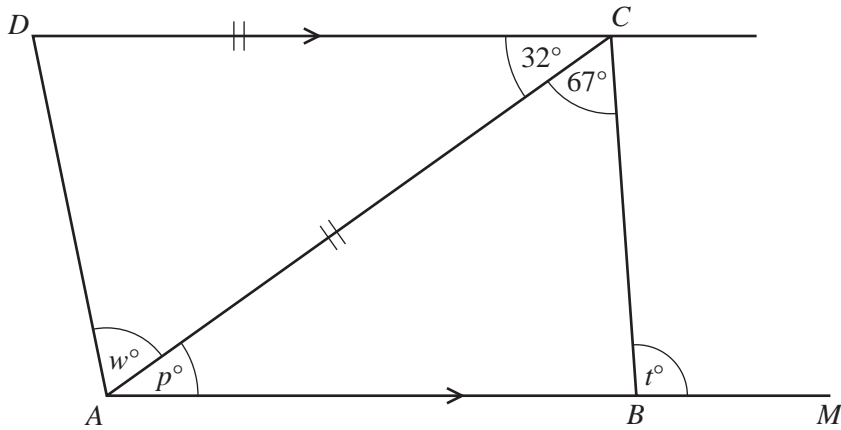

NOT TO
SCALE

The diagram shows a quadrilateral $ABCD$ with DC parallel to AB .

- (a) Write down the geometrical name for a quadrilateral with **only one** pair of parallel sides.

Answer(a) [1]

- (b) ABM is a straight line and $DC = AC$.
Angle $DCA = 32^\circ$ and angle $ACB = 67^\circ$.

Find the values of p , t and w , giving a reason for each answer.

Answer (b) $p =$ because [2]

$t =$ because [2]

$w =$ because [2]

BLANK PAGE

Permission to reproduce items where third-party owned material protected by copyright is included has been sought and cleared where possible. Every reasonable effort has been made by the publisher (UCLES) to trace copyright holders, but if any items requiring clearance have unwittingly been included, the publisher will be pleased to make amends at the earliest possible opportunity.

University of Cambridge International Examinations is part of the Cambridge Assessment Group. Cambridge Assessment is the brand name of University of Cambridge Local Examinations Syndicate (UCLES), which is itself a department of the University of Cambridge.