

# IGCSE

## Human Biology

### Teacher's guide

Edexcel IGCSE in Human Biology (4HB0)

First examination 2011

Edexcel, a Pearson company, is the UK's largest awarding body, offering academic and vocational qualifications and testing to more than 25,000 schools, colleges, employers and other places of learning in the UK and in over 100 countries worldwide. Qualifications include GCSE, IGCSE, AS and A Level, NVQ and our BTEC suite of vocational qualifications from entry level to BTEC Higher National Diplomas, recognised by employers and higher education institutions worldwide.

We deliver 9.4 million exam scripts each year, with more than 90% of exam papers marked onscreen annually. As part of Pearson, Edexcel continues to invest in cutting-edge technology that has revolutionised the examinations and assessment system. This includes the ability to provide detailed performance data to teachers and students which help to raise attainment.

### *Acknowledgements*

This guide has been produced by Edexcel on the basis of consultation with teachers, examiners, consultants and other interested parties. Edexcel would like to thank all those who contributed their time and expertise to its development.

*References to third-party material made in this document are made in good faith. Edexcel does not endorse, approve or accept responsibility for the content of materials, which may be subject to change, or any opinions expressed therein. (Material may include textbooks, journals, magazines and other publications and websites.)*

Authorised by Roger Beard  
Prepared by Phil Myers

All the material in this publication is copyright  
© Edexcel Limited 2008

## Introduction

The Edexcel International General Certificate of Secondary Education (IGCSE) in Human Biology is designed for schools and colleges. It is part of a suite of IGCSE qualifications offered by Edexcel.

### About this guide

This guide is for teachers who are delivering, or planning to deliver, the Edexcel IGCSE in Human Biology qualification. The guide supports you in delivering the course content and explains how to raise the achievement of your students. The guide:

- gives essential information on the changes between this qualification and existing Edexcel and other international qualifications in the subject
- provides details of Assessment Objectives (AO) and criteria
- includes a list of command words that are directly linked to the Assessment Objectives
- gives you an example course planner
- provides experimental and investigative work that should be incorporated into teaching
- offers you suggestions for a range of textbooks.



# Contents

<b>Why choose this qualification?</b>	<b>1</b>
<b>Support from Edexcel</b>	<b>2</b>
<b>Section A: Qualification content</b>	<b>3</b>
Introduction	3
Information for Edexcel centres	3
<b>Section B: Assessment</b>	<b>7</b>
Assessment overview	7
Assessment Objectives and weightings	7
Assessment summary	8
Examination questions	11
Command words	34
Using the mark scheme	34
<b>Section C: Planning and teaching</b>	<b>35</b>
Course planner	35
Teaching ideas — experimental and investigative work	48
Resources	59



## Why choose this qualification?

The Edexcel IGCSE in Human Biology has been developed to:

- give comprehensive and detailed subject content, with amplification to guide you
- include aspects of modern human biology appropriate for the 21st century
- offer straightforward linear assessment
- assess investigative skills through examination.

Go to [www.edexcel.com/igse2009](http://www.edexcel.com/igse2009) for more information about this IGCSE and related resources.

## Support from Edexcel

We are dedicated to giving you exceptional customer service. Details of our main support services are given below. They will all help you to keep up to date with IGCSE 2009.

### Website

Our dedicated microsite [www.edexcel.com/igcse2009](http://www.edexcel.com/igcse2009) is where you will find the resources and information you need to successfully deliver IGCSE qualifications. To stay ahead of all the latest developments visit the microsite and sign up for our email alerts.

### Ask Edexcel

Ask Edexcel is our free, comprehensive online enquiry service. Use Ask Edexcel to get the answer to your queries about the administration of all Edexcel qualifications. To ask a question please go to [www.edexcel.com/ask](http://www.edexcel.com/ask) and fill out the online form.

### Ask the Expert

This free service puts teachers in direct contact with over 200 senior examiners, moderators and external verifiers who will respond to subject-specific queries about IGCSE 2009 and other Edexcel qualifications.

You can contact our experts via email or by completing our online form. Go to [www.edexcel.com/asktheexpert](http://www.edexcel.com/asktheexpert) for contact details.

### Regional offices

If you have any queries about the IGCSE 2009 qualifications, or if you are interested in offering other Edexcel qualifications your Regional Development Manager can help you. Go to [www.edexcel.com/international](http://www.edexcel.com/international) for details of our regional offices.

### Head Office – London

If you have a question about IGCSE 2009 and are not sure who you need to ask, email us on [IGCSE2009@edexcel.com](mailto:IGCSE2009@edexcel.com) or call our Customer Services Team on +44 (0) 1204770696.

### Training

A programme of professional development and training courses, covering various aspects of the specification and examination is available. Go to [www.edexcel.com](http://www.edexcel.com) for details.



# Section A: Qualification content

## Introduction

The Edexcel IGCSE in Human Biology has been developed from the legacy Edexcel GCE O Level in Human Biology (7042). The IGCSE offers updated content whilst retaining the best features of the O Level.

The IGCSE in Human Biology forms part of the Edexcel IGCSE Sciences suite and has a similar assessment structure.

Some of the IGCSE in Human Biology content is shared with the Edexcel IGCSE in Biology (4BI0) and therefore this IGCSE could be co-taught with some of the IGCSE Biology providing students with a more in-depth understanding of human biology.

## Information for Edexcel centres

- Content from the legacy GCE O Level in Human Biology (7042) has been updated to reflect human biology in the 21st century.
- The specification includes action verbs to reflect what students need to know.
- The specification is divided into two sections: structure and function.
- Tiers have been removed.
- Investigative skills are embedded throughout.

## Comparison of the content from the Cambridge International Examinations (CIE) O Level in Human and Social Biology (5096) to this qualification

The table below shows how the content of the legacy Cambridge International Examinations (CIE) GCE O Level in Human and Social Biology qualification (5096) maps to this qualification.

Adapting from teaching the CIE course is simplified, as much of the content of the CIE and Edexcel specifications is common to both courses. Resources that are suitable for the CIE GCE O Level will, therefore, cover most of the Edexcel IGCSE. The additional content of the Edexcel course (particularly the quantitative work) will be covered by the many textbooks available at this level. Schools currently teaching the CIE GCE O Level should be able to continue with the same schemes of work as long as they are modified to reflect the changes in content.

Legacy CIE content (5096)	This qualification content reference	Content not in Edexcel
1 – Characteristics of living organisms	1 – Cells and tissues 2 – Biological molecules 3 – Movement of substances into and out of cells 13 – Non-pathogenic organisms and their importance	Carbon and nitrogen cycles
2 – Plants, food and humans	14 – Environment	N/A
3 – Nutrition and diet	6 – Nutrition and energy	N/A
4 – Digestion and absorption of food	6 – Nutrition and energy	N/A
5 – Blood and the circulatory system	9 – Internal transport	N/A
6 – Breathing and circulation	7 – Respiration	N/A
7 – Skeleton, muscles and movement	4 – Form and movement: bones, muscles and joints	N/A
8 – Homeostasis: Maintaining a steady internal environment	10 – Homeostatic mechanisms	N/A
9 – The senses, nervous system, hormones and coordination	5 – Coordination	N/A

<b>Legacy CIE content (5096)</b>	<b>This qualification content reference</b>	<b>Content not in Edexcel</b>
10 – Reproduction and the continuity of life	11 – Reproduction and heredity	N/A
11 – Health and disease	12 – Disease	N/A
12 – Control of disease	12 – Disease	N/A
13 – Immunity and immunisation	12 – Disease	N/A
14 – Community health	14 – Environment	N/A
15 – Pollution	14 – Environment	N/A



## Section B: Assessment

This section describes the nature of assessment for this qualification, including the logistics of examinations and what you can expect from the Edexcel examination papers.

### Assessment overview

The table below gives an overview of the assessment for this course.

We recommend that you make this information available to students to help ensure they are fully prepared and know exactly what to expect in each assessment.

Paper	Percentage	Marks	Time	Availability
Human Biology Paper 1	$66\frac{2}{3}$	120	2 hours	January and June examination series First assessment June 2011
Human Biology Paper 2	$33\frac{1}{3}$	60	1 hour	January and June examination series First assessment June 2011

### Assessment Objectives and weightings

	% in IGCSE
AO1: Knowledge and understanding	45-55%
AO2: Application of knowledge and understanding, analysis and evaluation	25-35%
AO3: Investigative skills	20%
<b>TOTAL</b>	<b>100%</b>

## Assessment summary

Paper 1	Description of paper 1	Knowledge and skills for both papers
<p>Human Biology Paper 1</p> <ul style="list-style-type: none"> <li>• The 2-hour paper is worth 120 marks. All questions are compulsory. The questions vary in style and demand, though most questions are structured in appearance, requiring a brief response in the allocated space. There will be some longer prose sections requiring students to write several sentences in their answers. The paper is not divided into sections.</li> <li>• The paper may include the following types of questions:               <ul style="list-style-type: none"> <li>– multiple choice</li> <li>– tables with data to complete or interpret</li> <li>– graphs to draw or interpret</li> <li>– simple mathematical calculations</li> <li>– diagrams to draw or complete, to label and to interpret</li> <li>– experimental data to interpret and comment on.</li> </ul> </li> <li>• Within many of the questions there will be a progression in difficulty, starting with a simple question and ending with something much more demanding.</li> </ul>	<p>The Assessment Objectives (AO) covered in this assessment are:</p> <p>AO1: 45-55%</p> <p>AO2: 25-35%</p> <p>AO3: 20%.</p> <p><b>AO1 Knowledge and understanding</b></p> <p>In the assessment of these skills students will be tested on their ability to:</p> <ul style="list-style-type: none"> <li>• recognise, recall and show understanding of biological facts, terminology and concepts</li> <li>• use existing knowledge to show an understanding of ethical, environmental, social, economic and technological applications and implications of biology</li> <li>• select, organise and present relevant material clearly and logically using appropriate vocabulary.</li> </ul> <p><b>AO2 Application of knowledge and understanding, analysis and evaluation</b></p> <p>In the assessment of these skills students will be tested on their ability to:</p> <ul style="list-style-type: none"> <li>• describe, explain and interpret phenomena, effects and ideas in terms of biological principles</li> <li>• present arguments clearly and logically</li> <li>• interpret and translate data presented in various forms from one form to another</li> <li>• carry out relevant calculations</li> <li>• apply biological principles and concepts in solving problems including those in unfamiliar situations</li> <li>• assess the validity of biological information experiments, inferences and statements and make informed judgements from them.</li> </ul>	<p>The Assessment Objectives (AO) covered in this assessment are:</p> <p>AO1: 45-55%</p> <p>AO2: 25-35%</p> <p>AO3: 20%.</p> <p><b>AO1 Knowledge and understanding</b></p> <p>In the assessment of these skills students will be tested on their ability to:</p> <ul style="list-style-type: none"> <li>• recognise, recall and show understanding of biological facts, terminology and concepts</li> <li>• use existing knowledge to show an understanding of ethical, environmental, social, economic and technological applications and implications of biology</li> <li>• select, organise and present relevant material clearly and logically using appropriate vocabulary.</li> </ul> <p><b>AO2 Application of knowledge and understanding, analysis and evaluation</b></p> <p>In the assessment of these skills students will be tested on their ability to:</p> <ul style="list-style-type: none"> <li>• describe, explain and interpret phenomena, effects and ideas in terms of biological principles</li> <li>• present arguments clearly and logically</li> <li>• interpret and translate data presented in various forms from one form to another</li> <li>• carry out relevant calculations</li> <li>• apply biological principles and concepts in solving problems including those in unfamiliar situations</li> <li>• assess the validity of biological information experiments, inferences and statements and make informed judgements from them.</li> </ul>

Paper 1	Description of paper 1	Knowledge and skills for both papers
<p>Human Biology Paper 1</p> <ul style="list-style-type: none"> <li>• Within the paper, approximately 40 marks are aimed at the A*/A/B grade boundaries, approximately 40 marks are aimed at the C/D boundary and approximately 40 marks are aimed at the E/F/G boundaries. This allows for the award of grades A* to G.</li> <li>• The paper assesses all parts of the specification content. Approximately 45-55 per cent of the paper assesses AO1, 25-35 per cent assesses AO2 and the remaining 20 per cent assesses the practical skills and understanding stated for AO3.</li> <li>• The skills in AO3 will be assessed either in combination with AO1 and AO2 in parts of questions, or as one or more whole questions expecting students to demonstrate the skills used in practical investigations.</li> </ul>	<p><b>AO3 Investigative skills</b></p> <p>In the assessment of these skills students will be tested on their ability to:</p> <ul style="list-style-type: none"> <li>• put forward a hypothesis to explain observations or data</li> <li>• devise and plan simple investigations to test a hypothesis</li> <li>• select and set up apparatus</li> <li>• discuss the factors that must be controlled to give validity to their results</li> <li>• show understanding of the need for safe practical techniques</li> <li>• suggest ways of obtaining reliability for their results</li> <li>• identify how they would determine the end point of their investigation, where appropriate</li> <li>• show how they would record and display their results</li> <li>• form valid conclusions from data.</li> </ul>	

<b>Paper 2</b>	<b>Description of Paper 2</b>	<b>Knowledge and skills</b>
<p>Human Biology Paper 2</p> <ul style="list-style-type: none"> <li>• The 1-hour paper is worth 60 marks. All questions are compulsory. The questions vary considerably in style but they are all aimed at A* to E grade students. The skills required are as for paper 1 but questions may require deeper and more specific understanding. The paper may include the following types of question.</li> <li>• A comprehension from which students will be expected to read a passage of biological information and answer questions based on its content.</li> <li>• A question that will require students to analyse data they are unlikely to have seen before.</li> <li>• A question that will require students to plot and make deductions from a graph.</li> <li>• Structured questions based on the content of the specification.</li> <li>• One question that will require the student to select relevant material from one or more sections of the specification. The answer will be written in continuous prose.</li> </ul> <p>The paper is not divided into sections.</p> <ul style="list-style-type: none"> <li>• All questions are aimed at A* to E grade students. Within many of the questions there will be a progression in difficulty, starting with a simple question and ending with something much more demanding.</li> <li>• Within the paper, approximately 30 marks are aimed at the A*/A/B grade boundaries and approximately 30 marks are aimed at the C/D/E boundary. This allows for the award of grades A* to E.</li> <li>• The paper assesses all parts of the specification. Approximately 45-55 per cent of the paper assesses AO1, 25-35 per cent assesses AO2 and the remaining 20 per cent assesses the practical skills and understanding as stated for AO3.</li> </ul>	<p>Students should be given opportunities throughout the course to analyse data that they have not seen before in order to prepare themselves for the data analysis question. Tasks that involve manipulation of mathematical data would also benefit student preparation.</p> <p>Data may be presented in the form of tables, graphs, diagrams or flow charts.</p> <p>Graph plotting skill is essential and students should be given every opportunity to appreciate the need to produce graphs with the independent and dependent variables on the correct axes. They should appreciate the importance of using linear scales on the axes and using a large amount of any grid provided. Plotting should be accurate and any lines drawn should be clear and not too thick. Students will be advised as to whether a line of best fit is required or whether points should be joined through the points using a ruler. Sometimes a bar graph may be examined and students need to be familiar with this style of graph plotting.</p> <p>Thereafter, this paper examines student ability to answer structured questions and to write prose that requires the processing of knowledge and understanding as opposed to rote recall.</p>	



## Examination questions

Assessment Objectives AO1 (Knowledge and understanding), AO2 (Application of knowledge and understanding, analysis and evaluation) and AO3 (Investigative skills) will be examined in both papers 1 and 2.

Various types of question will be used, allowing students to express their knowledge and understanding in different ways. Some of these question types are described in more detail below, with guidance on the way students should approach them in order to gain maximum credit.

### How should students respond to a question?

Before beginning to answer the first part of a question the student should read through the whole question and briefly consider what is to be included in the response to each part. It is highly unlikely that marks will be awarded for the same response to two parts of a question, so planning is essential.

The wording of each part of a question has been carefully considered to elicit a specific response. Students should take great care to consider the command words used in a question, for example ‘describe’ has a totally different meaning to ‘explain’ and different responses would be expected.

Special attention should be paid to any words emboldened in a question and also to the word ‘not’ if it occurs. Where a specific number of examples is requested, marks will be awarded only for that number. In lists containing many examples only the first examples will be credited up to the number required.

Students should pay attention to the mark allocations given at the end of each part of a question. This is especially true where a space for the response has several marks.

Example:

‘Describe how you would carry out a test for the presence of reducing sugar in a food’.

---

---

---

---

---

---

---

---

(4)

#### Answer guidance

Simply stating ‘carry out a Benedict’s test’ would gain only 1 mark. To gain further marks students would have to mention additional points such as:

‘place a small piece of the food in water’

‘heat the mixture of food, water and Benedict’s solution’

‘look for a colour change from blue to orange or red’

‘stating what colour change indicates a positive result’.

## Types of question

The types of questions used include the following.

### 1 Multiple-choice questions

In these questions, one of the four options must be chosen as the response and indicated as specified by the instructions given. Choice of more than one of the options will automatically result in no mark.

The following question is from the sample assessment material (SAM): paper 1 question 1(c)

(c) The diagram shows a section of the human eye.

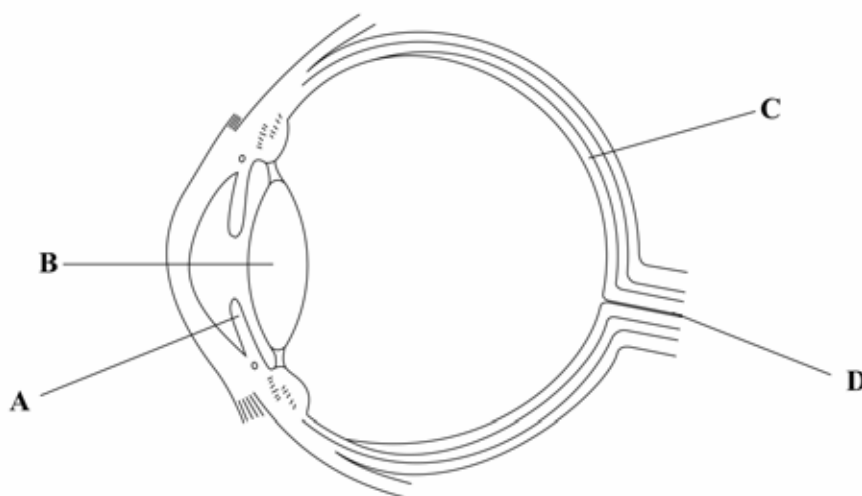

Which part of the eye detects light?

- A
- B
- C
- D

(1)

#### Answer guidance

Correct response is a cross, placed in the box opposite C.

A cross placed in any of the boxes opposite A, B or D would disqualify any response in C.

## 2 Questions involving tables with data

In questions in which data has to be interpreted, the question will give guidance to the student as to which aspects of the table are to be considered.

The following question is from the sample assessment material (SAM): paper 2 questions 3(a)(ii) and (b)(i).

3. The table below gives details of the incidence of HIV in six major continents.

Each of these gives some indication about social conditions in the same continents.

Continent	Europe	Africa	Asia	South America	North America	Oceania
% of 15 to 49 year olds with HIV infections	0.5	6.1	0.4	0.6	0.6	0.2
Life expectancy of child born in 2005 in years	75	52	65	72	78	73
% of population with access to a safe water supply	100	85	94	95	100	99
Infant mortality per 1000 live births	7	88	57	26	7	29
% of population living on a very low income	0	66	58	24	0	0

(a) (i) In which continent is the incidence of HIV infection lowest?

.....  
(1)

(ii) What is the relationship between the patterns of HIV infection and life expectancy?

Use data from the table to support your answer.

.....  
.....  
.....  
.....  
(2)

**Answer guidance**

In part (a)(ii) students are required to look at two aspects of the data – HIV infection and life expectancy – and to decide whether there is an obvious relationship between the two factors.

Example answer:

‘As the percentage of HIV infection increases the life expectancy gets shorter. This is seen by comparing the 0.2 per cent HIV infection in Oceania and a life expectancy of 73 years with that of Africa, 6.1 per cent HIV infection and life expectancy of 52 years.’

Students could have selected other comparisons with the data from Africa.

- (b) Some people claim that the incidence of HIV infections is related to social conditions. The table below gives information about three countries in one of the continents.

Country	X	Y	Z
% of 15 to 49 year olds with HIV infections	4.4	21.5	24.6
% of population with access to a safe water supply	81	98	100
Infant mortality per 1000 live births	100	43	62
% of population living on a very low income	78	34	83

- (i) Does the data in the table justify this claim? Explain your answer.

.....  
.....  
.....

(2)

**Answer guidance**

In part (b)(i) of the same question a table gives a more detailed breakdown for these factors in different countries in one of the continents. Here students are expected to use their judgement to decide if a claim about a relationship is valid.

Unless otherwise instructed, students should always confine their responses to the data provided.

Example answer

‘The claim is not justified. In country Y there is low infant mortality and it has few people on a low income but has a high percentage of HIV infections.’

The student could have made reference to the percentage with access to safe water supply as an alternative factor.

In some questions the table of data will be incomplete and students will be required to display knowledge and understanding by completing it.

5. (a) Some people carry donor cards like the one shown.

This means that when they die, their body parts can be given to people that need them.

The table gives the function of body parts that are commonly donated. Complete the table using words from the list.

- cornea      heart      kidney      lung**  
**pancreas      skin      liver**

Function	Donated body part
breaks down toxic chemicals	
fills with air during breathing	
bends light as it enters eye	
secretes insulin	

(4)

**Answer guidance**

Here the students must select the correct responses from the list given and not use terms from outside of the list. If they do they will gain no credit.

The responses from top to bottom of the table are:

Liver, lungs cornea and pancreas.

### 3 Questions involving graphs

Students may be required to draw or to interpret line graphs or bar charts.

#### Line graphs

When drawing a line graph it is important to select a suitable scale, using as much of the available grid as possible.

The X (horizontal) axis should display the independent variable. In an investigation of the effect of temperature on the activity of an enzyme the temperatures at which the activity is tested is the independent variable. The Y (vertical) axis should display the dependent variable. In this investigation this will be the time taken by the enzyme reaction to reach an end point.

The points should be plotted either by a spot surrounded by a circle  $\odot$  or by a small cross  $\times$  with the centre of the cross on the coordinates. The points should be joined by a single, clear line. Usually the line is drawn point to point but in some cases a line of best fit is appropriate. Both axes need to be fully labelled and if more than one line is plotted on the same axes the lines should be labelled or a key given.

Students may be asked to read off intermediate points from their graph or to predict additional data.

## Bar charts

The following question is from the sample assessment material (SAM): paper 1 question 3 (a).

3. (a) The bar chart shows the number of cases of the sexually transmitted disease, gonorrhoea, affecting people of different ages in a country in one year.

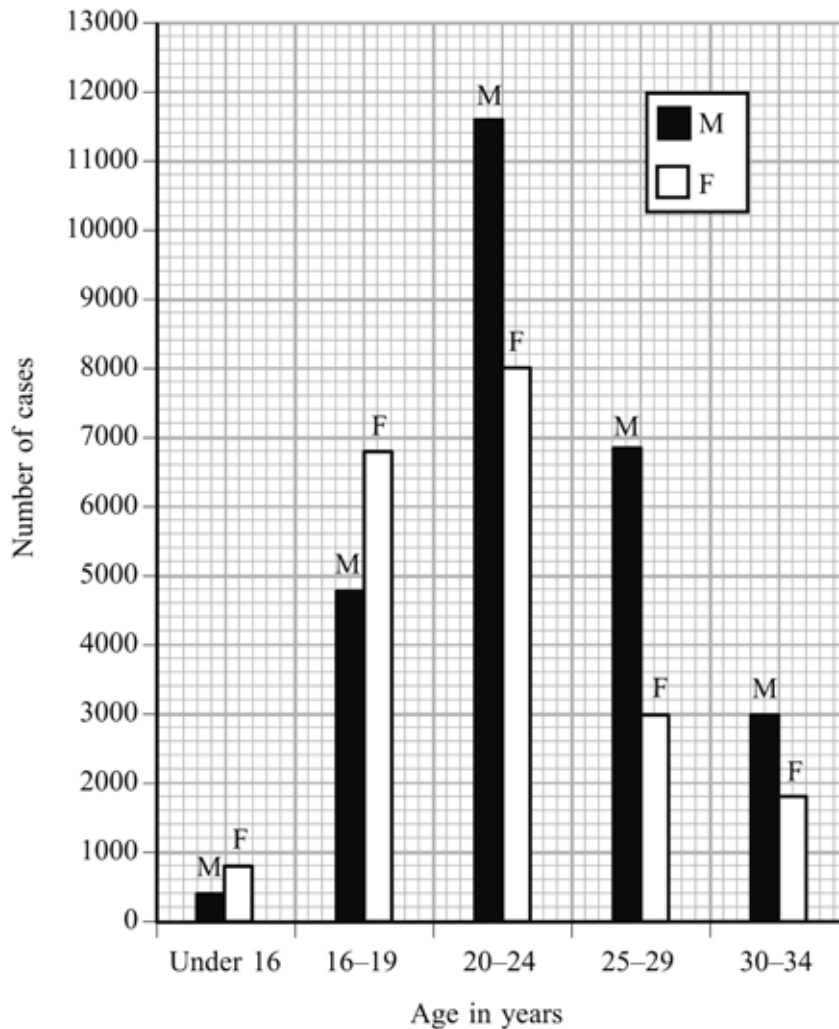

- (i) How many cases of the disease were there during the year in men aged 30-34?

.....  
(1)

- (ii) How many cases of the disease were there during the year in women aged 20-24?

.....  
(1)

(iii) Which age group has the greatest number of cases of the disease in males and females?

.....  
(1)

**Answer guidance**

Students are expected to extract data from the bar chart. Note that the vertical scale has been carefully chosen and labelled. The horizontal scale has been selected to show every bar clearly. All the bars should be, and are, of the same width. This also illustrates the use of a key to identify the bars.

The correct responses are:

(a) (i) 3000

(a) (ii) 8000

(a) (iii) 20–24.



#### 4 Mathematical calculations

Questions may be set demanding the use of simple mathematical calculations, including addition, subtraction, multiplication and division.

The question will be of a biological nature and the calculation will be an incidental part of the question.

The following question is from the sample assessment material (SAM): paper 2 question 6 (b).

- (b) The table below shows the composition of air breathed in and air breathed out of the lungs at rest.

Gas	Percentage composition of air	
	Air breathed in	Air breathed out
Oxygen	21	17
Carbon dioxide	0.03	4
Nitrogen	78	78
Other gases	less than 1	1

Use the table, the graph and your answers to (a) to calculate the amount of oxygen taken into the blood in one minute at rest.

Show your working.

Answer ..... dm<sup>3</sup>  
(2)

**Answer guidance**

When instructed to do so, the student should show their working, even if using a calculator. Credit may be given if the correct method is used, even if the answer is less than perfect. Units should be stated where relevant.

Example answer:

‘Air breathed in has 21 per cent oxygen, air breathed out has 17 per cent.

$21\% - 17\% = 4\%$  oxygen taken into blood.

Volume of air breathed in 1 minute

$= 12 \text{ breaths} \quad \times \quad 0.5 \text{ dm}^3 \quad \times \quad 4/100$

(from (a)(ii))                      (from (a)(iii))

$= 0.24 \text{ dm}^3$ .

This would gain full credit as it shows working and gives the correct answer.

## 5 Questions involving diagrams

Students may be requested to complete or draw a diagram to illustrate biological knowledge and understanding. All diagrams should be as large as the space allows, drawn in pencil and fully labelled. A sharp outline is required without shading or colouring. Label lines should terminate exactly at the item being indicated. Usually only limited credit is given for the quality of the drawing and more credit is given for correct labels. Sometimes annotations are more appropriate than single-word labels.

The following question is from the January 2006 paper 1 question 6 (b)(i).

- (b) (i) The diagram below shows the front of the eye. Complete the diagram to show how the iris and pupil would appear in a dark room.

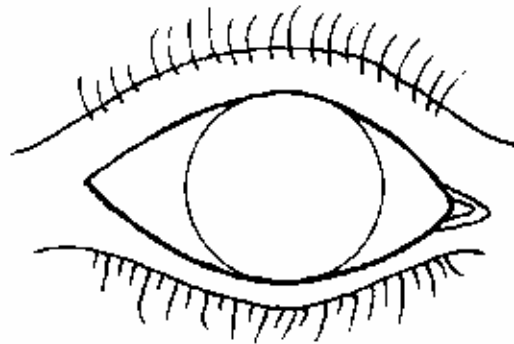

(2)

### Answer guidance

An enlarged pupil is drawn within the iris.

Students are advised to label what they have added to the diagram.

## 6 Questions involving data to interpret and comment on

Great care should be taken to look at the command words in these questions.

‘Compare’ requires comments to be made on each of the two sets of results, while ‘explain’ requires details of the underlying biology that has brought about that result.

The following question is from the sample assessment material (SAM): paper 1 question 4 (c)(iii).

- (c) The diagrams below show the apparatus used by a student to investigate the digestion of starch at two different temperatures.

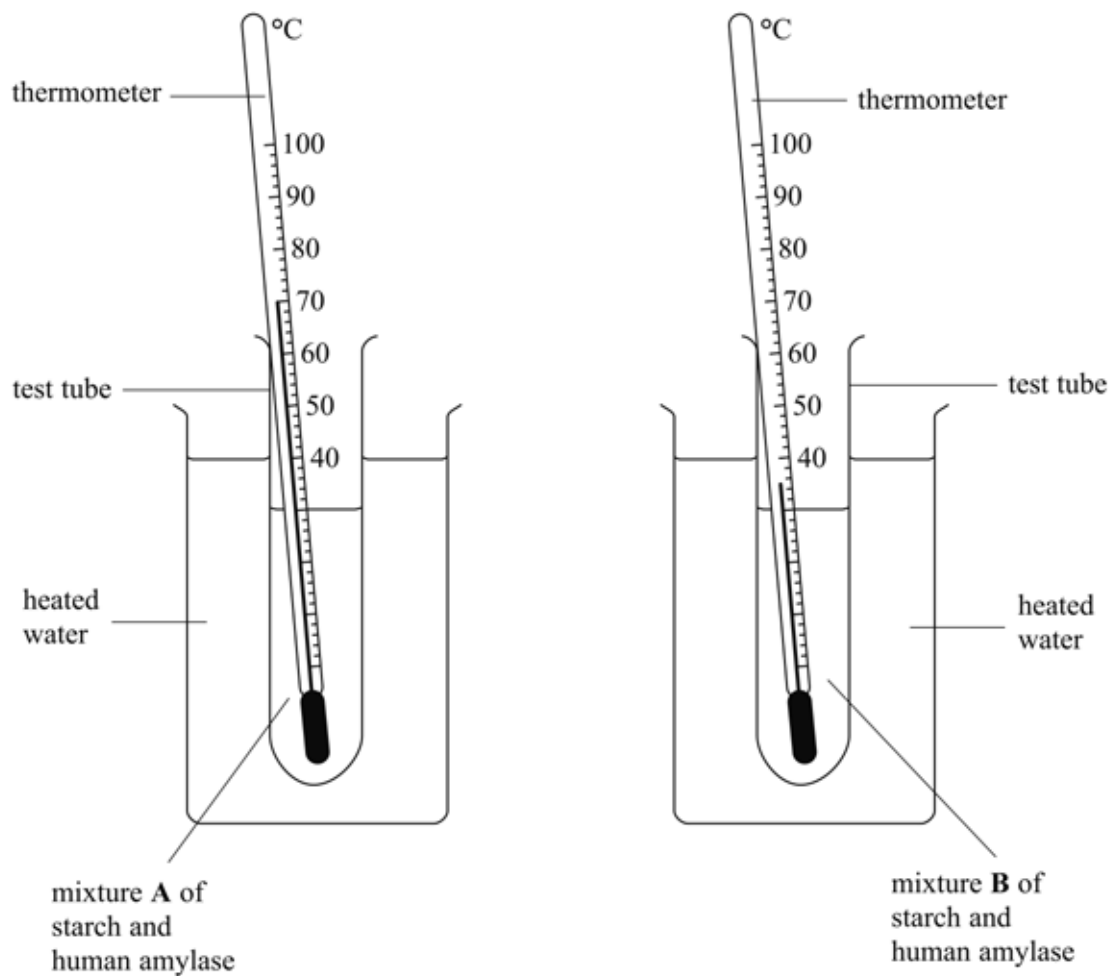

(iii) State in which of the two mixtures the starch would be digested most quickly and explain why.

.....

.....

.....

.....

**(3)**

**Example answer**

‘The mixture in tube **B** would be digested most rapidly as the temperature in tube **A** is so high and the enzyme would have been denatured.’

The following question is from the sample assessment material (SAM): paper 2 question 3 (b)(ii).

- (b) Some people claim that the incidence of HIV infections is related to social conditions. The table below gives information about three countries in one of the continents.

Country	X	Y	Z
% of 15 to 49 year olds with HIV infections	4.4	21.5	24.6
% of population with access to a safe water supply	81	98	100
Infant mortality per 1000 live births	100	43	62
% of population living on a very low income	78	34	83

- (i) Does the data in the table justify this claim? Explain your answer.

.....

.....

.....

(2)

- (ii) No cure is known for AIDS but people with a higher standard of living may be able to delay the onset of AIDS-related infections.

Suggest one way by which a higher standard of living may delay this onset.

.....

.....

(1)

Students might be asked for ways in which an investigation or its results could be made more reliable or open to more useful interpretation. In this case, the command word 'suggest' may be used as there may be several alternative correct answers and students can draw on knowledge from various sources.

**Answer guidance**

Students should think about the problem posed and try to formulate a logical response such as:

'The onset of AIDS might be delayed if good medical facilities are available and the patient can afford suitable drugs.'

Or

'A better diet might increase resistance to secondary infections.'

The following question is from the sample assessment material (SAM): paper 2 questions 5 (b)(i) and (ii).

5. The diagram below shows the carbon cycle.

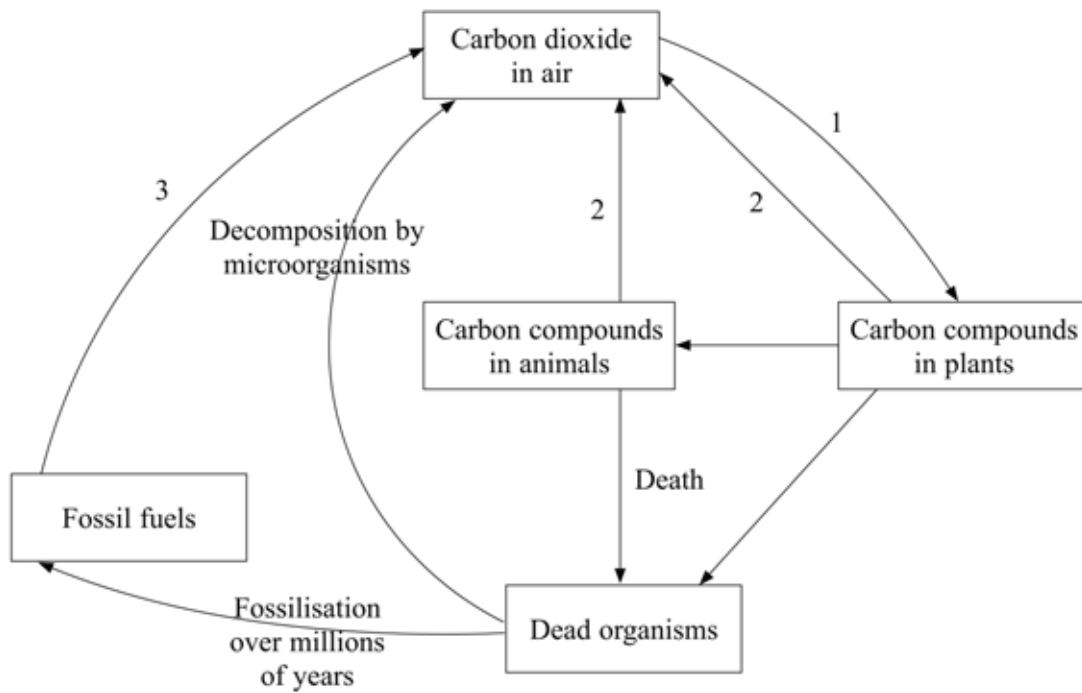

(b) Many people are concerned that the carbon dioxide concentration in the air appears to be increasing.

(i) Use information in the diagram to explain why this may be happening.

.....

.....

.....

.....

(2)

(ii) A rise in carbon dioxide concentration is linked to increased global warming.

Suggest **one** likely harmful effect of global warming on agriculture.

.....

.....

(1)

**Example answers**

(b)(i)

‘Because of a need for more energy there is more combustion, which releases more carbon dioxide into the air. Also the carbon dioxide trapped as part of fossil fuels a very long time ago is now being released.’

(b)(ii)

‘This might lead to flooding by sea water of low lying farming land.’

Or

‘Could cause a change in temperature that will prevent some crops being grown.’

Or

‘This could lead to droughts causing damage to animal and crop farming.’



## 7 Questions involving experimental skills

Experimental and investigative skills will be examined in both papers 1 and 2.

Some of the questions may form part of a larger question, such as forming a conclusion from data, but others may be of a completely practical nature.

Students will be expected to demonstrate their familiarity with the problems of designing and carrying out practical investigations – not just their theoretical knowledge.

The following question is from the sample assessment material (SAM): paper 2 question 1 (a)(ii).

1. A student used the apparatus shown below to determine the energy value of a small cheese biscuit.

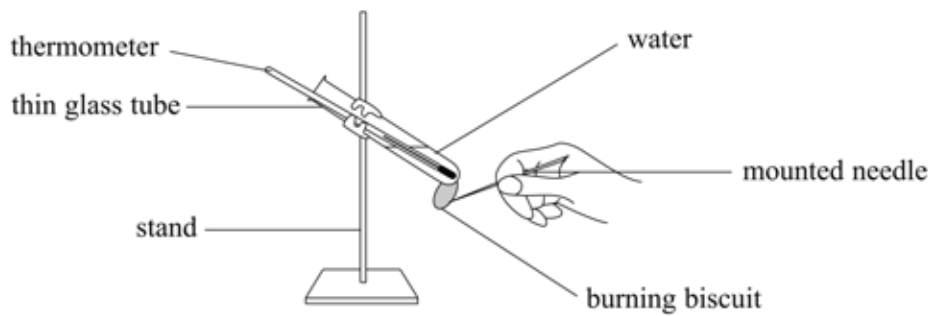

The student held the biscuit on a mounted needle. She placed the biscuit in a Bunsen flame so that it began to burn. She then immediately placed the burning biscuit under the thin glass tube, which contained 8 g of water at 15 °C.

As the biscuit burned, its energy was transferred to the water in the tube. The temperature of this water rose to 95 °C.

It takes 4.2 J of energy to raise the temperature of 1 g of water by 1 °C.

- (a) (i) Calculate the energy, in kilojoules, released when the biscuit was burnt.

= ..... kJ  
**(3)**

- (ii) Give a reason why the change in the temperature of the water may not represent all the energy in the food.

.....  
.....

**(1)**

**Answer guidance**

Responding to this question will be easier for students who have carried out a similar experiment. They will be familiar with the problems of burning food in this manner. For example, the food may stop burning before all of it has been burnt in this manner or the last bit may fall off of the needle. Also they may have realised that, if the burning food is held too far from the boiling tube, more heat is lost in the air.

Students may also have discovered that it is virtually impossible to cut a piece of food to an exact mass and that other techniques have to be used. There are other points that that could be made in part (a)(ii), such as heat lost when transferring the burning food to the correct position below the tube or that energy is lost as light.

The following question is from the sample assessment material (SAM): paper 2 question 1 (b).

- (b) A student decides to use this method to find out which of two foods will have the greatest amount of energy.

Describe two safety precautions the student would have to take if an accurate comparison is to be made.

1 .....

.....

2 .....

.....

(2)

**Answer guidance**

Students should think of ‘fair’ comparisons.

Example answers:

‘Use the same volume/mass of water to investigate each of the two foods.’

Or

‘Keep the burning food the same distance below the tube in each investigation.’

Or

‘Weigh the food before burning and then work out the amount of heat produced per g of food.’

The following question is from the sample assessment material (SAM): paper 2 question 6 (c)(i).

(c) A student is provided with the apparatus shown in the diagram below.

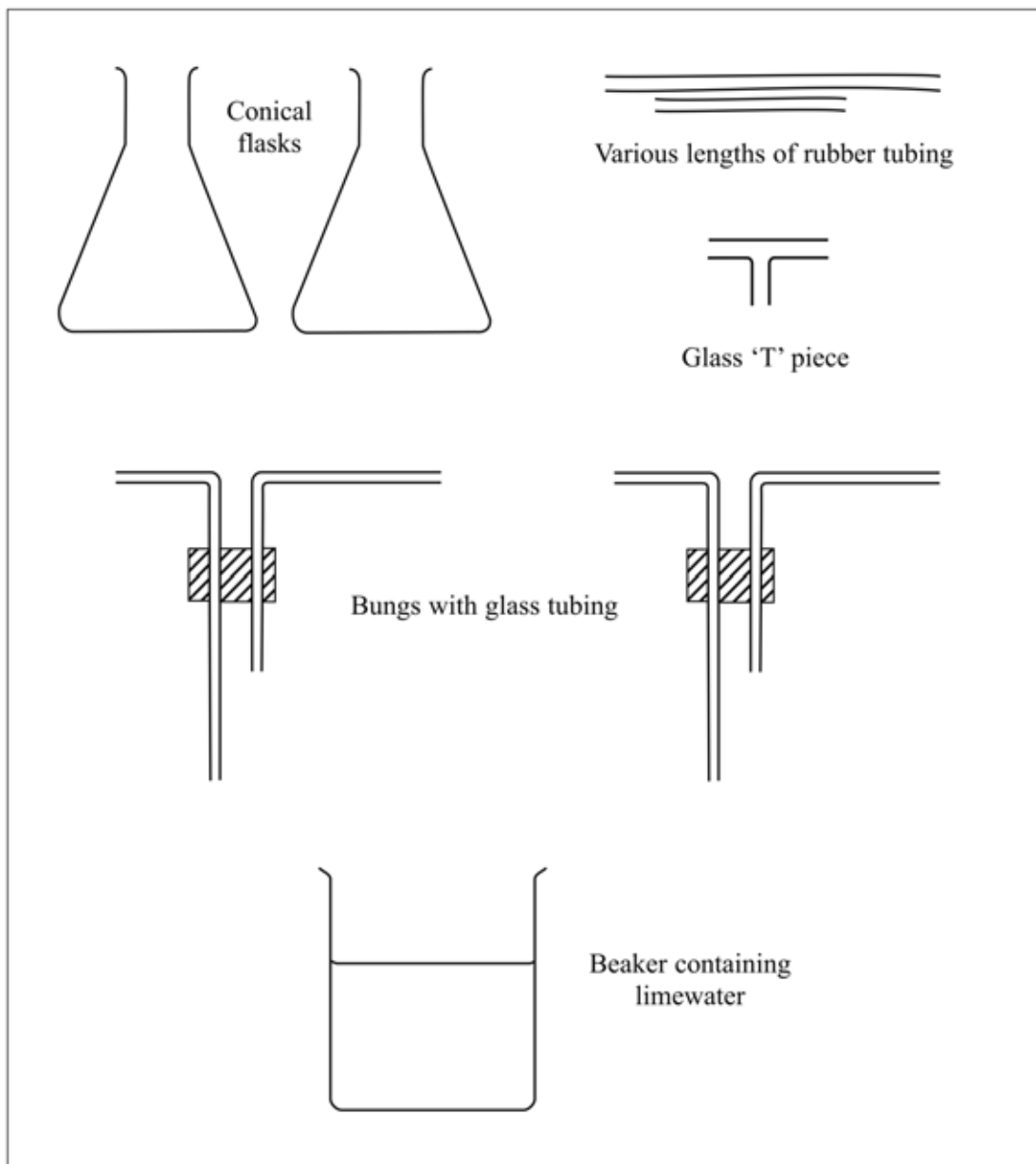

- (i) Draw a labelled diagram to show how the student could assemble the apparatus to compare the carbon dioxide content of inspired and expired air. Use all the equipment.

In this question students are required to redraw the apparatus as it should be assembled to compare samples of inhaled and exhaled air. Students are expected to put equal volumes of limewater into each flask with the long tube going below the surface of the limewater and the short tube well clear of the surface. The apparatus should be assembled with the arm of one short tube connected to the 'T' piece (to breathe in and out through) and the arm of a long tube from the second flask connected to the other side of the 'T' piece.

The guidance indicates a successful response to this question.

**Mark Scheme**

Apparatus in correct sequence/T piece connected to both flasks.

Long tube from each bung in limewater.

Short tube above level of limewater.

**Answer guidance**

Failure to do this correctly would result in the user either getting a mouthful of limewater or the limewater being blown out of the flask. This kind of safety precaution would be familiar to students who have carried out a similar investigation. They may also realise how hard it is to breathe the same volume of air in and out to make a fair comparison.

Students should appreciate the problems involved in using their fellow students for experimental work. Designing controls can be very difficult as humans have such varied backgrounds and physical features.

New question

Suggest how you could carry out an investigation to compare the pulse rates of a class of 14-year olds with those of a class of 16-year olds.

**Answer guidance**

There is enormous variation in health, diet, body mass and fitness within each group. Thus age will not be the only variable between the two groups.

Students should at least consider these factors, and others they identify, and try to establish ways of reducing the effects of some of them to try to collect data with greater reliability and validity.

Students should recognise that collecting data by means of a survey is always dubious and has very limited value scientifically.

## 8 Questions involving continuous prose

Short answers requiring continuous prose responses will form part of the structured questions in either paper 1 or 2. Students should take note of the space provided for the response as well as the mark allocation when deciding the depth of response required. The command terms should indicate the nature of the response. Questions of this type may have a mark allocation of 2-5 marks.

In paper 2 students are expected to complete one question requiring a longer prose response. They must select material relevant to the topic of the question from their knowledge and understanding of the syllabus, and express their ideas in clear scientific terms. This tests students' ability to plan, select material and use it to put together a reasoned response. The topic of the question may involve material from several areas of the syllabus.

The following question is from the sample assessment material (SAM): paper 2 question 7.

7. Describe the role of negative feedback in the regulation of blood glucose concentration by hormones produced in the pancreas.

The mark descriptors for this in the mark scheme show how this type of question will be awarded credit using a subjective mark scheme.

## Mark Scheme for Paper 2 Question 7

Question number	Required content
7	<p><b>Negative feedback:</b></p> <ul style="list-style-type: none"> <li>• an increase or decrease in a factor is detected</li> <li>• this triggers a response that returns the factor to normal.</li> </ul> <p><b>Increasing blood glucose concentration:</b></p> <ul style="list-style-type: none"> <li>• concentration rises</li> <li>• detected by cells in islets of langerhans/pancreas</li> <li>• (beta) cells secrete insulin</li> <li>• insulin stimulated liver to store glucose as glycogen</li> <li>• blood glucose concentration falls.</li> </ul> <p><b>Decreasing blood glucose concentration:</b></p> <ul style="list-style-type: none"> <li>• concentration falls (below normal)</li> <li>• after exercise/respiration</li> <li>• detected by cells in islets of langerhans/pancreas</li> <li>• (alpha) cells secrete glucagon</li> <li>• liver release glucose from glycogen</li> <li>• blood glucose concentration rises.</li> </ul>

Level	Mark	Descriptor
1	1-2	Only one area covered, correct facts very limited, poor spelling and use of scientific terms.
2	3-4	Only two areas attempted, factual errors occur, some scientific terms used correctly.
3	5-6	Two areas covered, most facts correct, correct use of scientific terminology.
4	7-8	All three areas covered, most facts correct, correct use of scientific terminology, continuous prose must be used.

**Answer guidance**

There are many starting points for the response in this case. Students might begin with an explanation of the term ‘negative feedback’ or an account of the function of the hormones produced by the pancreas. They may even start with the reasons for changes in the blood glucose concentration.

If all of these concepts are dealt with in some detail then they are likely to gain maximum credit. Students who deal with only one of these areas, such as the role of insulin and its effects, are likely to get only very limited credit.

The correct use of scientific terms, and their spelling, is important and students who include in correct or irrelevant information will find their maximum credit will be reduced.

A student who shows confusion between glucagon and glycogen will not gain maximum credit even if the rest of the response were to merit it. Likewise, a student who writes a lot about diabetes and its treatment will also be unlikely to gain maximum credit as this material is irrelevant for this response.

Students should appreciate that it is not only the biological detail that is included but how this detail is used within the response that will gain credit. They are advised to give some thought to a simple plan for their responses.

Also, students whose answer is simply a series of bullet points will reduce the maximum credit they can gain.

## Command words

Terms used within the papers include the following:

- **Calculate** – students may be asked to perform calculations
- **Compare** – students should offer similarities and differences between the items being compared. This should not be answered by writing two quite separate paragraphs that deal separately with the two items
- **Describe** – students should offer a response that includes the fundamental facts about the item or process for which the description is requested
- **Design** – students may be asked to design an experiment
- **Explain** – students should offer a response that utilises the underlying principles and concepts involved
- **Name** – students should offer the name of the object or process in question. They should not describe or explain it
- **Plot/draw/complete/measure** – students may be asked questions requiring them to plot data, draw diagrams, complete tables or measure drawn apparatus
- **State/identify** – students should offer a concise response without an explanation unless one is requested
- **Suggest** – students will be expected to offer a logical response, not based on recall of knowledge, but on applying the principles and concepts gained during the course. This may be related to new situations or may relate to familiar situations in which there is no single correct response.

## Using the mark scheme

The mark scheme gives the responses we expect from students. Indicative answers are given but during the standardisation of examiners process the mark scheme is updated and expanded to cover unexpected, correct student responses.



## Section C: Planning and teaching

### Course planner

The scheme shown in the table that follows is a suggested time allocation for each topic for teaching over five terms of 10 weeks each and assuming two hours of teaching each week. This can be adapted easily to fit local circumstances.

Teachers may wish to plan their own scheme. This is perfectly acceptable and allows a degree of flexibility, but any approach must ensure full coverage of the specification content.

Some topics (such as 1, 2 and 3) may be covered best at appropriate points in the course and integrated with other topics rather than being covered as discrete topics.

Teachers may prefer to start the course with a topic at least partially familiar to students such as topic 6 (nutrition and energy). However, the starting point can be any topic chosen and then other topics can be fitted into a sequence that is chosen.

This course plan includes the practical work from the specification, but teachers are encouraged to include additional practical work as appropriate to interests, and the time and facilities available.

Topic	Suggested time allocation
1 – Cells and tissues	Topics 1 to 3 have a total time allocation of 5 weeks. This time has been reallocated to relevant topics to which the content has been linked.
2 – Biological molecules	
3 – Movement of substances in and out of cells	
4 – Form and function: bones, muscles and joints	3 weeks
5 – Coordination	6 weeks
6 – Nutrition and energy	6 weeks
7 – Respiration	2 weeks
8 – Gaseous exchange	4 weeks
9 – Internal transport	4 weeks
10 – Homeostatic mechanisms	7 weeks
11 – Reproduction and heredity	7 weeks
12 – Disease	3 weeks
13 – Non-pathogenic organisms	1 week
14 – Environment	7 weeks

Below are more details of a possible sequence covering the whole of the content in the specification. For further clarification, they should be looked at in conjunction with the details in the specification.

## Topic 2 – Biological molecules, Topic 6 – Nutrition and energy, 6 weeks

Section	Content detail	Specification reference	Practical work
Food and diet	Classes of foods, sources and uses within the body	2a), 2b), 2c), 6c)	Food tests for starch, reducing sugars, lipids and protein.
Balanced diet	Balanced diet and variation with age, activity, pregnancy, etc Energy requirements and variation with size, age, activity, pregnancy, etc	6a), 6b) 6d)	Determining energy content of foods.
Malnutrition	Deficiency diseases including protein deficiency, rickets and anaemia	6e)	
Fibre	Role of fibre; sources in diet Peristalsis	6g)	
Alimentary canal	Identify the regions listed and describe their functions	6f)	
Digestion	Enzymes Role of digestive enzymes listed in specification Production and role of bile. Emulsification	2d), 2e), 6h) 2f), 6m) 6i)	Carry out simple experiments with enzymes.
Absorption	Structure and function of villi	6j)	
Teeth	Structure and functions of teeth, causes of tooth decay	6k)	

**Topic 1 – Cells and tissues, Topic 4 – Form and function: bones, muscles, joints, 3 weeks**

Section	Content detail	Specification reference	Practical work
The cell	Cell structure as seen with a light microscope and an electron microscope; function of cell parts	1a)	Make slide of cheek cells. Examine photographs and prepared slides of cells.
Nucleus and DNA	DNA structure and the link to protein formation	1b)	
Cell division	Mitosis and cell division Mechanism of nuclear division in outline only	1c)	Examine photographs and slides of mitosis.
Grouping of cells	Cells, tissues and organs – muscle, bone and cartilage tissues Healthy development of these tissues	1d), 1e) 4f)	
The skeleton	Main bones – label on diagram	4a)	If possible examine skeleton.
Functions of the skeleton	Support, movement, protection, production of red blood cells, etc Roles of bone and cartilage	4b) 1d)	
Movement	Types of joint Structure of synovial joints Raising and lowering of forearm – roles of bones, muscles, nerves, tendons and ligaments, etc	4c) 4d) 4e), 1d)	Examine own arm.

## Topic 5 – Coordination, 6 weeks

Section	Content detail	Specification reference	Practical work
Neurones	Types of nerve cells	5a), 1d)	
Nervous system	Plan of nervous system, brain and spinal cord	5b), 5d)	
Nerve impulse	The nerve impulse and transfer across synapse	5c)	Possibly investigate speed of nerve impulses.
Reflex actions	Structure of reflex arc Withdrawal reflex	5e) 5f)	Investigate the knee jerk reflex.
The brain	Identify and state main functions of main regions	5g)	
The sense organs	Receptor cells and organs	5h)	Practical on sensitivity of skin.
The eye	Structure of the eye; blink reflex Functions of the iris reflex mechanism Focusing on near and distant objects Brief account of colour vision	5i)	Study model eye. Examine pupil under bright and dim light.
The ear	Basic structure and function in balance and hearing	5l)(i)	
Hormones	Name the main hormone producing glands, their secretions and the main functions of each hormone	5l)(ii)	
Hormonal feedback mechanism	Negative feedback best illustrated by control of blood glucose concentration (insulin and glucagon) and by temperature regulation	5k)	
Need for coordination	Role of nerves and hormones and comparison of their modes of action	5j)	

## Topic 7 – Respiration, 2 weeks

Section	Content detail	Specification reference	Practical work
Respiration	Define respiration; explain importance of process	7a)	
Aerobic respiration	Word and chemical equation for aerobic respiration; uses of energy released	7c), 7d)	Simple experiments to demonstrate carbon dioxide release in humans.
Anaerobic respiration	Word equation for anaerobic respiration Explain formation of lactic acid Concept of oxygen debt	7f)	Experiment to demonstrate anaerobic respiration in yeast.
Comparison of types of respiration	Make clear the differences between aerobic and anaerobic respiration and when and where each occurs in humans	7b)	
ATP and mitochondria	Role of ATP in respiration; role of mitochondria	7e)	

**Topic 8 – Gas exchange, Topic 3 – Movement of substances in and out of cells, 4 weeks**

Section	Content detail	Specification reference	Practical work
Organs of gas exchange	Label diagram to show organs within thorax	8a)	
Maintaining the airways	Role of ciliated epithelium and mucus in cleaning airways; role of cartilage in trachea	1d)	Examine slides of tissues. If possible examine pluck (heart, trachea, lungs) of a mammal.
Breathing	Role of ribs, diaphragm and intercostals muscles in breathing  Volume of air inhaled under various conditions; explain terminology; study spirometer traces	8b)  8d), 8g)	Use model of thorax.  Measure vital capacity and tidal volume.  Experiment to investigate the effect of exercise on breathing.
Alveolar structure	Diagram of alveolus and blood supply; role of alveolus	8c)	
Diffusion	Definition of diffusion; factors affecting diffusion	3a), 3b), 3c), 3d)	Experiments to demonstrate diffusion.
Control of blood gases	Explain how concentrations of oxygen and carbon dioxide in the blood are regulated	8e)	
Health and disease	Discuss the benefits of regular exercise  Smoking – look at and discuss data on the effects of smoking on the gas exchange system. Mention bronchitis and lung cancer	8h)  8f)	Possibly make a smoking machine.

## Topic 9 – Internal transport, 4 weeks

Section	Content detail	Specification reference	Practical work
Blood	Composition	9a)	
Blood cells	Structure and function of red blood cells Structure and function of white blood cells	9d), 1d) 9e), 1d)	Examine prepared slides of blood.
Platelets	Role of platelets Process of clotting	9f)	
Plasma	Composition and role Link to tissue fluid	9c) 9m)	
ABO blood groups	Blood transfusion; understand blood groups and incompatibility	9g)	
Transplants	Discuss problems of transplants including rejection	9h)	
Genetically inherited conditions	Inheritance of sickle cell anaemia and haemophilia; link to Topic 11	9b), 11q)	
Circulation	Identify and label on diagrams the blood vessels to and from the heart, lungs, liver and kidneys	9n)	
Blood vessels	Structure and functions of arteries, veins and capillaries; the pulse	9l)	Measuring pulse rate.
The heart	Identify and label on diagrams the parts of the heart. Understand its role as ‘two’ pumps. Functioning of the heart Factors affecting heart rate	9i) 9k)	Investigating the effect of exercise on heart rate.
Heart attacks	Understand the causes and effects of heart attacks	9j)	

## Topic 10 – Homeostatic mechanisms, 7 weeks

Section	Content detail	Specification reference	Practical work
Homeostasis	Understand the principle of maintaining a constant internal environment in spite of changes in activity and in the external environment; link to Topics 5 and 8	10a), 10b) 5k), 8e)	
The skin	Structure of the skin; identify and label main features on a diagram	10c)	
Homoiothermy	Regulation of body temperature – understand the role of sweat glands, blood vessels and shivering in maintaining body temperature Link to Topic 2	10c) 2f)	
Excretion	Definition – removal of metabolic waste such as urea, water and carbon dioxide; link to sweating, main excretory organs and osmoregulation	10d), 10f), 10g)	
The urinary system	Identify and label main parts of the urinary system on a diagram; draw and label section through kidney	10h), 10e)	
Nephron	Recognise the regions of a nephron and their main roles	10i)	
Ultrafiltration	Function of Bowman’s capsule	10j)	
Selective reabsorption	Role of convoluted tubules and the collecting duct Osmosis and active transport	10k), 10l) 3a), 3b), 3d)	Simple experiments on osmosis.
Role of ADH	Describe osmoregulation – the roles of the pituitary gland and the kidney	10m)	
Urine	Composition of urine – affect of various conditions on composition of urine	10e), 10n)	
Dialysis	Discuss the value and problems associated with kidney transplants; understand the principle of kidney dialysis	10o)	
ORT	Explain the importance of rehydration; the method and principle of oral rehydration treatment (ORT)	10p), 10q)	
The liver	List the functions of the liver; link to Topics 2 and 6; its role in deamination, glycogen storage, bile formation and detoxification	10r) 2i), 6i), 6j)	
Alcohol	Effects of alcohol on body, both short and long term; social, behavioural problems and damage to liver, heart etc; discussion of effects of alcohol on driving skills	10s)	Analysis of data of alcohol-related deaths



## Topic 11 – Reproduction and heredity (A), 7 weeks

Section	Content detail	Specification reference	Practical work
Gametes	Structure of ovum and sperm	11a)	
Meiosis	Its role in gamete formation; the process in outline; important principles of crossing over and haploid gametes; link to Topic 1	11b) 11x), 1c)	Examine prepared slides of meiosis.
Fertilisation	Restoration of the diploid condition; the random nature of fertilisation	11a), 11e), 11w)	
Reproductive systems	Identify and label drawings of the main parts of reproductive systems; state the functions of main structures	11c)	
Menstrual cycle	Hormonal control; functions of the main hormones in cycle and in maintaining pregnancy; link to Topic 5	11d), 5i)	
Zygote	Formation of zygote and development of embryo; role of amnion	11e), 11g)	
The placenta	Identify and label drawing; structure of the placenta; role of placenta in nutrition, gaseous exchange and excretion	11f)	
Birth	Outline of birth process; value of breast feeding	11i)	
Birth control	Methods of contraception Ways of increasing chance of pregnancy	11k)	
Post natal development	Development between birth and maturity in outline; stages such as childhood and adolescence	11j)	
Secondary sexual characteristics	Roles of oestrogen and testosterone at puberty	11h)	

## Topic 11 – Reproduction and heredity (*continued*) (B)

Section	Content detail	Specification reference	Practical work
Inheritance	The relationship between DNA, genes and chromosomes; link to Topic 1	11l), 11m), 1b)	
The allele	Definition of an allele and relationship to gene	11n)	
Genetics and monohybrid cross	Simple monohybrid inheritance showing how alleles pass from parent to offspring Understanding of terminology and symbols	11o), 11q)	
Genetic diagrams	Draw and interpret diagrams of genetic crosses and predict outcomes; interpret family pedigrees; including cystic fibrosis and sickle cell anaemia	11s), 11r)	
Codominance	The ABO blood group system	1p)	
Sex	Determination of sex; role of X and Y chromosomes	11t), 11u)	
Sex linkage	Sex linked inheritance including haemophilia and red-green colour blindness	11v)	
Variation	General principle of variation within species due to genetic and environmental factors	11y)	
Mutation	Genetic changes (often but not always detrimental); usually very rare	11z), 11aa)	
Natural selection	The general principles	11bb)	
Mutagens	Factors that cause an increase in the rate of mutation; link to skin cancer and lung cancer	11cc)	

## Topic 12 – Disease, 3 weeks

Section	Content detail	Specification reference	Practical work
Disease	Concept of something wrong with working of body; revisit diseases already studied		
Causes of disease?	Diabetes Deficiency diseases Bronchitis and lung cancer Inherited diseases Link to Topics 5, 6, 8 and 9	5i) 6e) 8f) 9b)	
Infectious diseases	Understand infection, incubation, signs and symptoms of disease	12a)(i)	
Patterns of disease	Endemic and epidemic disease	12a)(ii)	
Viruses	Structure of viruses; transmission, treatment and prevention of influenza, polio and HIV	12b)(i)	
Bacteria	Structure of typical bacterium Transmission, treatment and prevention of typhoid, tuberculosis and gonorrhoea	12b)(ii) 12b)(iii)	Preparation of agar plates and the culturing of non-pathogenic bacteria.
Fungi	Transmission, treatment and prevention of thrush and athlete's foot	12b)(iv)	
Animal parasites and vectors	Schistosomiasis; role of vector in spread of disease; control of infection Relationship between mosquito and malaria; control of infection The housefly and the spread of typhoid Control of infection	12c)(i) 12c)(ii) 12c)(ii)	
Defence against disease	Role of white blood cells; link to Topic 9 Immunity	9e) 12d)(i)	
Vaccines	The antigen/antibody reaction Know what a vaccine is and how it is produced; explain how it works	12d)(iii) 12d)(ii)	Study and discuss local vaccination programmes.
Antibiotics	Understand the role of antibiotics	12d)(iv)	

## Topic 13 – Non-pathogenic organisms, 1 week

Section	Content detail	Specification reference	Practical work
Decay	The role of bacteria and fungi in decomposition The value of this process in recycling	13a)	
Sewage treatment	Explain this as a form of decay turning harmful wastes into reusable materials Students should be familiar with flow charts of the sewage treatment process, the role of each step and the role of different micro-organisms; they should also study the process of pit latrine disposal	13b)	Possible visit to sewage treatment works

## Topic 14 – Humans and the environment, 7 weeks

Section	Content detail	Specification reference	Practical work
Resources	Understand that resources are finite; understand that there is a need to conserve resources and avoid environmental change	14a)	
Photosynthesis	Understand the dependence of humans on green plants for food and oxygen Know the word equation for photosynthesis Describe and interpret investigations relating to photosynthesis	14b) 14c)	Test green leaves for starch. Show that plants produce oxygen. Demonstrate the need for light, carbon dioxide and chlorophyll.
Food chains	Describe the flow and the loss of energy and substances along a food chain Recall the terminology of the trophic levels; understand the role of decomposers in recycling; link to Topic 13	14e), 14f) 14d), 13a)	
Food hygiene	Understand the need for food preservation and the scientific principles behind the various methods that ensure the food is safe and palatable after storage	14g)	
Water supply	Recognise the need for a clean safe water supply; describe events in a water treatment plant including the need for and the mechanisms of filtration; chlorination	14h)	
Contamination of water	Problems caused by the contamination of water by untreated sewage; risk of cholera and the depletion of oxygen in the water	14i)	
Eutrophication	Causes including treated sewage and excessive use of fertilisers; effect on life in ponds and streams	14j)	
The air	The normal composition of the air and the consequences of pollution by sulphur dioxide (acid rain) and carbon monoxide (from incomplete combustion); dangers to health	14k)	
Global warming	Know the gases that are helping to increase the mean temperature of the atmosphere	14l)	
Human activities	Understand how the activities of humans appear to be adding to the problem of global warming	14m), 14n)	
Deforestation	Effects on the water and carbon cycles; effects on the soil and the air	14o)	
Other hazards	Harmful effects of ultra-violet light, x rays, etc	14p)	

## Teaching ideas – experimental and investigative work

Experimental work is an integral part of the study of human biology so it is appropriate that assessment of experimental and investigative skills should form approximately 20 per cent of the final assessment.

It is strongly recommended that 20 per cent of the teaching time should be devoted to practical work carried out by the students themselves. However, there may be circumstances where it is possible for the work to be carried out only in small groups or even by demonstration alone. Between 24 and 30 of the 120 marks in Paper 1 will be set as questions with a practical bias, along with approximately 12 of the 60 marks in Paper 2.

Many of the topics in the specification should be taught in a way that allows the facts to arise from practical work, rather than the practical work being used to demonstrate what students have already been taught.

Students are expected to acquire skills that allow them to be assessed on their ability to:

- plan experimental procedures
- describe practical techniques and take measurements
- analyse evidence and draw conclusions, communicating findings using calculations, tables and graphs
- evaluate evidence.

The sample assessment materials, which comprise of mark schemes, have been produced to illustrate the types of question that will be asked.

The following key points are of vital importance in all practical work and this importance should be understood by students.

- Having a control, or a range of values for the independent variable.
- Ensuring standardisation of the biological materials involved.
- Replication to ensure reliability.
- Measuring quantitatively, accurately and with precision.
- Ensuring standardisation of all other variables that could influence measurement of the dependent variable.

## Training students in practical skills

Students should be offered as many opportunities as possible to plan and carry out experimental tasks and whole investigations themselves, and to practise the skills needed to achieve their highest potential in this work.

Many students will need considerable guidance in order to progress from simply carrying out a set of practical instructions provided by the teacher, to the point where they are able to plan and carry out a whole investigation themselves, and critically evaluate the outcome. However, the effort required will be well rewarded, as the student will then fully understand the principles and parameters on which scientific method is based. Indeed, the heuristic approach to teaching human biology will help students to absorb the practical skills on which they will be assessed, and it will enable them to tackle questions with greater confidence.

Students will benefit from being introduced to the concept of practical investigative work before they begin the course. Evidence has shown that students take a considerable time to gain the confidence needed for higher-level investigative skills such as critical evaluation.

Students might be given the opportunity to attempt whole investigations. Before this, they should be given experimental tasks that test only one or two skill areas. For example, as an introduction to the concept of planning whole investigations, students could be asked to write a plan for an experiment that is subsequently carried out in class.

Students should be encouraged to participate in practical work wherever possible. The scheme is designed to encourage a wide variety of activities, including those based on the collection of first-hand evidence and those that depend on secondary evidence. (The term 'evidence' is used to mean observations, measurements or other data.)

A list of the practical work and investigations that are included in the specification is given below, together with a small sample of other practicals. This practical work will give students opportunities to acquire necessary skills. It is hoped that teachers will extend the list for their students to allow them to gain further confidence in practical work, its analysis and evaluation.

When planning investigations, any local health and safety guidelines should always be followed and particular care taken if human material is used. Students' health must be considered if they are to be the subject of an investigation.

## Practical work and student investigations

- 1 Tests for glucose and starch, lipid and protein. A test for the presence of carbon dioxide in air
- 2 Controlled experiments to illustrate how enzyme activity can be affected by changes in temperature
- 3 Simple experiments on diffusion and osmosis using living and non-living systems
- 4 Controlled experiments to investigate photosynthesis, showing the evolution of oxygen from a water plant, the production of starch, and the requirements of light, carbon dioxide and chlorophyll
- 5 A simple experiment to determine the energy content of a food sample
- 6 A simple experiment to compare the amount of carbon dioxide in inspired and expired air
- 7 An investigation to measure a person's vital capacity
- 8 A simple experiment to investigate the effect of exercise on breathing in humans
- 9 A simple experiment to investigate the effect of exercise on heart rate in humans
- 10 A simple experiment to investigate how the sensitivity of the skin differs in various regions of the hand
- 11 Culturing micro-organisms on agar plates
- 12 A simple experiment to investigate carbon dioxide production by yeast in different conditions

Advice on how to approach each of the listed experiments or investigations is given below. It is not obligatory to follow this advice; it is recognised that there are many ways in which the practical work could be carried out to fulfil the training in practical skills.



## 1 Tests for glucose, starch, lipid and protein (part 1)

The tests that are expected:

- Benedict's test for glucose
- iodine test for starch
- the emulsion test for lipid
- biuret reagent for protein.

These tests could be carried out:

- on prepared samples of pure substances
- on foods that contain the substances
- in a context.

### Example

To demonstrate health applications, a fake 'urine sample' can be made by colouring water with iodine solution. A similar solution, with glucose added, could mimic the urine of an untreated diabetic. Students can use Benedict's test to identify the diabetic.

## 1 Test for the presence of carbon dioxide in air (part 2)

Tests to show the presence of carbon dioxide in air by bubbling air through a detector chemical.

Bubble air through lime water – goes milky in the presence of carbon dioxide. Warning – if the test is continued after the milkiness appears it can then go clear again as the calcium carbonate formed is converted to soluble calcium hydrogen carbonate.

Bubble air through hydrogen carbonate (bicarbonate) indicator. This changes colour from red to yellow, which shows the presence of an acidic gas, normally carbon dioxide depending on the context. The red colour occurs when the concentration of carbon dioxide in the indicator is approximately the same as normal atmospheric air. The yellow colour occurs when the concentration of carbon dioxide is significantly greater than in atmospheric air.

Both tests can be used to compare the difference in carbon dioxide in inhaled and exhaled air or for comparisons of exhaled air produced under varying circumstances such as exercise.

## 2 Controlled experiments to illustrate how enzyme activity can be affected by changes in temperature

The effect of amylase on starch digestion is a particularly easy system to use. At each temperature selected, from 0°C to 100°C, samples of amylase solution and of starch solution are brought to temperature before being added together. The mixture is then kept at the same temperature. To measure the rate of reaction, drops of the mixture can be collected at intervals of one minute and added to individual iodine drops on a white tile. The time taken for the starch to disappear is recorded for each temperature.

Temperature-controlled water baths help the students, but stable temperatures can also be achieved by using beakers of water, thermometers, ice and Bunsen burners.

There is plenty of scope for students working individually to plan how to keep all variables except for temperature the same, to consider repetition, to display their results in tables and to plot them as graphs, and to evaluate their results.

Catalase is another enzyme that can be used. There are a number of sources, but potato or liver are most commonly used. Catalase converts hydrogen peroxide into water and oxygen. The rate of oxygen production can be measured as an indication of enzyme activity. An upturned burette previously filled with water can be used to collect and measure the volume of oxygen evolved. Hydrogen peroxide is toxic and so great care needs to be taken with its use.

### 3 Simple experiments on diffusion and osmosis using living and non-living systems

- a Cubes of agar jelly placed into solutions of methylene blue or potassium permanganate will absorb the pigment by diffusion. The cubes are left in the pigmented solution for different measured periods of time and are then sliced open. The distance between the edge of each cube and the edge of the coloured agar may be used as a measure of the distance the pigment molecules have moved by diffusion.
- b A crystal of potassium permanganate can be dropped into a beaker of water and the appearance of the water noted over time.
- c To demonstrate osmosis, Visking tubing (dialysis tubing) can be tied at one end and filled with 20 per cent sucrose solution. The other end is attached to a capillary tube. The level of the sucrose can be noted before and after the tubing has been placed in a beaker of water for about 30 minutes.
- d Onion epidermis can be peeled away, cut into squares and mounted on slides in different concentrations of sucrose solution. Observation under a microscope will show the effects of osmosis.
- e Red blood cells in blood obtained from a butcher may be mounted on slides in hypotonic, isotonic and hypertonic saline, and observed under a microscope to show the effects of osmosis.
- f Osmosis can be demonstrated by using strips of potato, and this basic experimental method provides a good opportunity for students to carry out individual whole investigations. Because of the difficulty of the osmosis concept, it is better to keep this investigation until the latter part of the course so that students will have had previous experience of carrying out investigations on simpler topics. Students enjoy the reference to 'chips', but should quickly realise that it can be difficult to keep the size constant – to achieve consistency lengths of potato tissue can be drilled from a potato using a cork borer. The 'chips' are measured by mass or by length and are placed into sucrose solutions of different concentrations for at least one hour. The percentage change in mass or length is a measure of the degree of osmosis that has occurred.
- g A variation on this theme is to cut potato cubes of different sizes, which have different surface area to volume ratios. After measuring and recording the masses of the cubes, they are immersed in water. After one hour, the cubes are blotted dry and their masses measured and recorded again. The percentage increase in mass for cubes of different surface area to mass ratio can be compared, to explore the concept of how surface area to volume ratio influences water uptake.

#### 4 Controlled experiments to investigate photosynthesis, showing the evolution of oxygen from a water plant, the production of starch and the requirements for light, carbon dioxide and chlorophyll

Students should appreciate the importance of photosynthesis in providing oxygen and food for other living organisms.

- a The evolution of oxygen from a water plant can be seen if a water plant (typically *elodea* or a similar species) is placed in a beaker of water and covered with a glass funnel that has a water-filled test tube placed over its opening. After 24 hours, a colourless gas will have displaced water from the test tube. A test for oxygen is then carried out.
- b To measure the rate of oxygen production, the stem of a water plant is cut under water, and the plant kept immersed in water in a beaker or boiling tube. The number of bubbles of gas given off over a measured time period can be counted. This simple experimental set up can enable students to carry out individual investigations into the effect of different factors on the rate of bubble production. Suitable variables include: light intensity (the plant is exposed to a light source and the rate of bubble production measured at different light intensities by changing the distance between the light source and the water plant); colour/wavelength of light (coloured filters are placed between the plant and the light source); and carbon dioxide availability (the plant is immersed in solutions of different concentration of sodium hydrogen carbonate).
- c Starch production can be investigated by placing a plant in the dark for at least 24 hours to de-starch the leaves. A starch test on a leaf from a plant that has been kept in the dark will not give a blue-black colour, whereas a similar test on a control leaf from a plant kept in the light will give a blue-black colour.
- d A starch test on a variegated leaf can be used to demonstrate that chlorophyll is needed for photosynthesis.
- e To show that carbon dioxide is needed for photosynthesis a leaf on a plant may be surrounded by air with no carbon dioxide by inserting it into a conical flask containing a small amount of potassium or sodium hydroxide. The plant is left in good light for 24 hours. The test leaf and a control leaf from the plant are then tested for starch\*.

\*To test leaves for starch:

- drop into very hot/boiling water for one minute (to destroy the cell membranes so that chlorophyll molecules can pass through)
- drop into hot ethanol (to remove/dissolve the green chlorophyll)
- place leaf into water (to rehydrate and soften the leaf so that it can be spread out)
- drop iodine solution onto the leaf (test for starch) – blue-black colour will show the presence of starch.

These experiments provide opportunities for students to demonstrate safe handling of equipment and materials and in the use of controls.

## 5 A simple experiment to determine the energy content of a food sample

Fat-containing foods such as dried crisps work very well.

- A known mass of the food sample is weighed and the mass noted.
- A boiling tube is prepared, containing a known volume of water. The water temperature is recorded.
- The food sample is put in a crucible or burning spoon and ignited (for example in the flame of a Bunsen burner).
- The food sample is quickly placed under the boiling tube. As soon as the food sample has completely burnt the water temperature in the boiling tube is re-measured.
- The equation used to calculate the energy content of the food is:

$$\frac{\text{Energy content of food sample (joules per gram)}}{\text{mass of water heated (g) x temperature rise (}^{\circ}\text{C) x 4.2 x 1/mass of food sample (g)}}$$

**Warning! Peanuts should not be used as the food sample because some people have a serious allergic reaction to them.**

To obtain an accurate result, all the energy in the food sample needs to be transferred to the water. Students could be asked to think of the reasons **why** this method produces an inaccurate result and to suggest ways in which the apparatus could be modified to make the result more accurate.

## 6 A simple experiment to compare the amount of carbon dioxide in inspired and expired air

Students breathe in through one conical flask and breathe out through a second flask, both of which contain equal volumes of limewater. After a time the limewater in one flask will turn cloudy before this occurs in the other.

Care must be taken in carrying out the experiment to ensure no limewater is taken into the mouth or sprayed into the room.

This can be repeated after gentle exercise. Students can discuss ways of identifying and timing the end point to obtain fair comparisons and the necessity to repeat the investigation several times.

This experiment can be modified to investigate other differences between inspired and expired air such as temperature and humidity.

## 7 An investigation to measure a person's vital capacity

This can be done either as a class practical or in small groups. Students should take turns to measure their own vital capacity. Each student should use either a fresh piece of tubing or the tubing must be sterilised with an antiseptic before each use.

Each group will need a large plastic bottle (or similar) holding about six litres, a large bowl or access to a sink. Each student needs a suitable length of rubber or plastic tubing.

Place 500 cm<sup>3</sup> of water in the bottle and mark the level on the outside with a chinagraph pencil. Then add another 500 cm<sup>3</sup> of water and mark again. Continue with this until the bottle is totally full and marked in 500 cm<sup>3</sup> intervals.

Put sufficient water in to the bowl to allow the bottle full of water to be inverted in the bowl with the neck of the bottle submerged by about 2 cm, but the water remaining in the bottle.

One student should place one end of the tubing in to the neck of the bottle and breathe out. The air expelled from the lungs will displace water from the bottle and the volume of air expelled can be measured.

To measure the vital capacity the student should first inhale as deeply as possible before exhaling as fully as possible.

Students can discuss class results and look for patterns between males and females, sporting and non-sporting students, shorter and taller students, etc.

Students could be asked to complete a questionnaire on diet, exercise or smoking habits before doing the investigation and the results should be discussed in the light of their comments.

Students could also be asked to consider other factors that might affect vital capacity such as general health, age, body mass, etc.

The health of students must be considered if they are to be the subject of this investigation with regard to asthma or other breathing conditions.

## 8 A simple experiment to investigate the effect of exercise on breathing in humans

The breathing rate can be measured at rest and after a period of exercise by counting the number of inhalations per minute.

To help students appreciate that exercise also influences the rate of breathing by increasing the volume of each breath, they can measure the volume of one exhalation before and after exercise. This can be done by breathing through a tube into a plastic container filled with water. The volume of displaced water can be measured, as in experiment 7. The total volume of air inhaled per minute, at rest and after exercise, can be calculated as the number of breaths per minute x volume of each breath.

Students may need to work in pairs: one to carry out the investigation and take measurements and the other as the subject of the investigation.

Students' health must be considered if they are to be the subject of this investigation with regard to asthma or other breathing conditions.

## **9 A simple experiment to investigate the effect of exercise on heart rate in humans**

Students should measure their pulse rate at rest. This is done by placing a finger (not the thumb) over the radial artery, just above the wrist, in line with the thumb. Count the number of pulse beats per minute. Repeat this at least twice more and calculate a mean.

Now carry out a short period of exercise such as stepping on and off a low step or running on the spot etc. The exercise needs to be supervised.

Now count the pulse rate again for one minute immediately after the exercise stops. Continue counting the pulse rate at two minute intervals until the pulse rate returns to its original level and record how long this takes (the recovery time). Repeat this experiment two more times and calculate a mean.

Students could pool their results and discuss possible causes for variations in resting pulse rates, the increase as a result of exercise and the recovery times. These could include age, mass, sex, fitness, etc. They could discuss whether there are other ways in which the volume of blood pumped by the heart (cardiac output) could be increased.

The investigation could be extended if a reliable way of measuring the amount of exercise (work done) can be devised.

Students' health must be considered if they are to be the subject of this investigation with regard to any known health conditions.

## **10 A simple experiment to show how the sensitivity of the skin differs in various regions of the hand**

Students should work in pairs. A piece of hard cardboard or cork can be used to fix the two prongs of a hairpin or two pins 5 mm apart. This is then used by a student to lightly touch the fingertips of another student, who is looking away. The first student can use either both points or one point as a stimulus. The second student then has to judge whether one or two points were used and their response recorded as correct or incorrect. This can be repeated ten times for each area of the hand. It is then repeated using pins 1 cm apart and 2 cm apart.

Students can then identify the most sensitive area as this should have the most correct responses with the smaller distance. Conclusions can be made about the number of sensory nerve endings, receptive field size and the thickness of skin. This practical also provides opportunities to discuss data analysis, experiment design and anomalous results, and the benefits of grouping class results.

## 11 Culturing micro-organisms on agar plates

Sterile Petri dishes containing nutrient agar jelly need to be set up, or students can be provided with bottles of sterile agar that they can melt and pour into sterile Petri dishes. The lid must be placed in position immediately and the dish left on a cool, flat surface until the jelly has set.

Micro-organisms can be collected from a variety of sites by a cotton wool bud, moistened with distilled water, and rubbed over the surface of an object. A person's fingers or teeth would be suitable. Other suitable sites could be the desk or workbench, unwashed fruit or vegetables, door handles, pens and pencils etc. Also, samples of liquids can be examined in a similar manner. Students should NOT be allowed to take samples from toilets, drains and similar sites.

A drop of distilled water is placed on the surface of the agar in a Petri dish, as soon as it is opened, and then the cotton bud is wiped through this and over the surface of the agar jelly in a zigzag. Immediately replace the lid of the Petri dish and seal it with clear adhesive tape.

The dish is incubated for 24 hours at 25°C. A higher temperature is likely to encourage the growth of any human pathogens present and this should be avoided.

After 24 hours observe the surface of the agar jelly through the lid of the Petri dish. Do not open the dish under any circumstances.

Any micro-organisms present in the original sample may have formed colonies that show up as spots on the surface of the agar jelly.

When the Petri dishes are finished with they should be submerged in a container of disinfectant. They should then be treated in an appropriate way to ensure that all live bacteria or spores are destroyed.

This can be extended to compare the effectiveness of cleaning hands with soap, the various heat treatments of milk, the comparative effectiveness of cleaning fluids on table tops where food is prepared or eaten, etc.

When planning investigations any local health and safety guidelines should always be followed.

## 12 A simple experiment to investigate carbon dioxide production by yeast in different conditions

This allows students to see that carbon dioxide is released during anaerobic respiration (fermentation). Students add yeast to glucose solution in a side-arm test tube. Anaerobic conditions are achieved by putting a drop of oil (cooking oil will do) onto the glucose and yeast mixture. A rubber tube is attached to the side arm of the test tube and a glass pipette is inserted at the other end of the rubber tube. The narrow end of the pipette is placed under water to allow the bubbles of carbon dioxide gas to be counted. Temperature is the easiest condition to investigate. Glucose concentration and pH could also be investigated.



## Resources

Please note that while resources are correct at the time of publication, they may be updated or withdrawn from circulation.

Gadd P – *Human and Social Biology* (Macmillan, 1982) ISBN 9780333329566

Mackean D G and Jones B M – *Introduction to Human and Social Biology* (Hodder, 1987)  
ISBN 0719541670

November 2008

For more information on Edexcel and BTEC qualifications  
please visit our website: [www.edexcel.com](http://www.edexcel.com)

Edexcel Limited. Registered in England and Wales No. 4496750  
Registered Office: One90 High Holborn, London WC1V 7BH. VAT Reg No 780 0898 07