

GCSE

**Specimen Papers and Mark Schemes**

**Edexcel GCSE  
Design & Technology: Resistant Materials  
Technology  
Full course (1973)**

**For First Examination  
Summer 2003**

***Edexcel***  
*Success through qualifications*

**Edexcel is one of the leading examining and awarding bodies in the UK and throughout the world. We provide a wide range of qualifications including academic, vocational, occupational and specific programmes for employers.**

**Through a network of UK and overseas offices, Edexcel's centres receive the support they need to help them deliver their education and training programmes to learners.**

**For further information please call our Customer Response Centre on 0870 240 9800, or visit our website at [www.edexcel.org.uk](http://www.edexcel.org.uk)**

**Autumn 2000**

**Publications Code **UG 009336****

**All the material in this publication is copyright**

**© Autumn 2000 Edexcel**

**Edexcel Foundation is a registered charity and a company limited by guarantee.**

**Registered in England No. 1686164**

# Contents

Specimen Paper 2F	p 1
Specimen Paper 2H	p 15
Specimen Mark Scheme 2F	p 29
Specimen Mark Scheme 2H	p 32
Specification Grid Papers 2F & 2H	p 34





**Answer ALL questions in the spaces provided.**





*Leave blank*

1. The table below shows either some tools or components or equipment.

(a) Complete the table by:

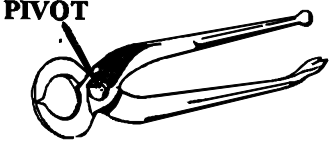
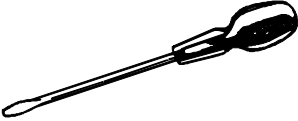
- (i) naming each tool or component or equipment;
- (ii) describing its use.

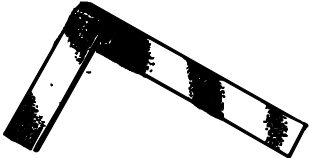
The first one is done for you.

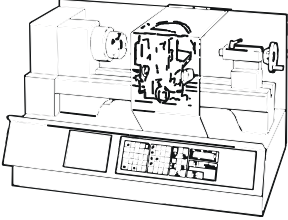
TOOLS /COMPONENTS / EQUIPMENT	NAME	USE
	PINCERS	PULLING NAILS FROM WOOD
		
		
		
		
		

**(10)**

(b) The pincers use a round head rivet for the pivot.

(i) Draw a clear outline of a round head rivet.

*Leave blank*

**(2)**

(ii) Describe how the round end of the rivet is formed to make a suitable pivot for the pincers using school workshop equipment.

.....  
.....  
.....  
.....

**(3)**

(c) Pincers are used to pull nails from pieces of wood.

Describe how pincers would be used to pull a nail from a piece of softwood without bruising the surface of the wood.

.....  
.....  
.....  
.....

**(3)**

(d) Manufacturers buy components such as nails as a standard component.

*Leave blank*

(i) Explain what is meant by a *standard component*.

.....  
.....

**(2)**

(ii) Give **two** advantages of using standard components.

1.....  
.....  
2.....  
.....

**(2)**

**(Total 22 marks)**



2. The drawing below shows an idea for a young child's pull along toy tortoise.

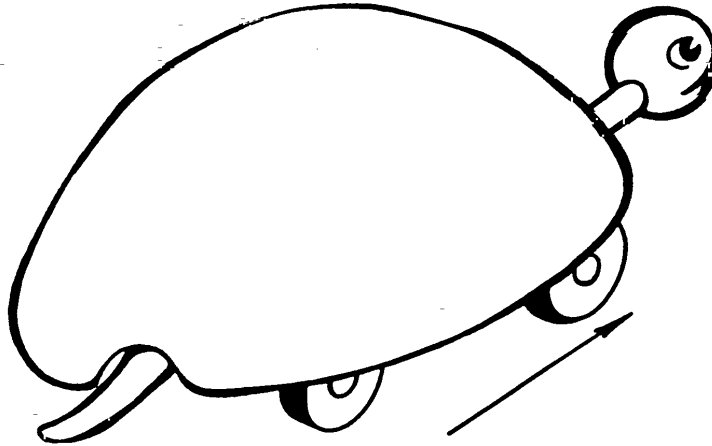

(a) The drawing below shows some detail of the chassis.

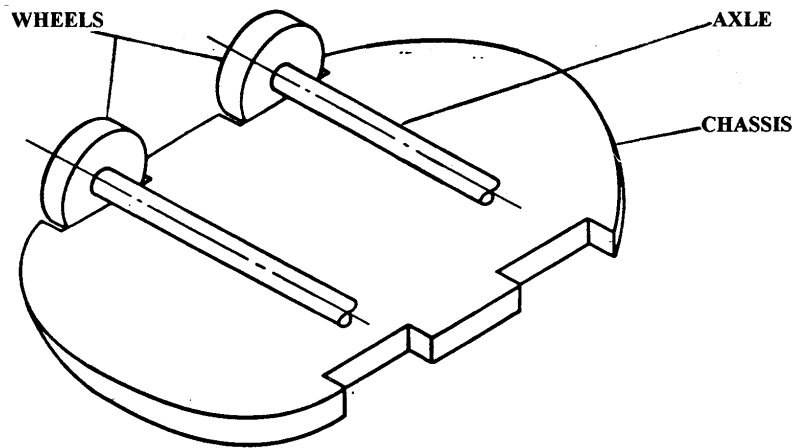

(i) Name **two** materials suitable for the axles.

1. ....

2. ....

(2)

(ii) The wheels are to be made of 9mm thick plastic and have a 6mm hole drilled in the centre.

Name a suitable material for the plastic wheels.

.....

(1)

(iii) Use notes and sketches to add to the drawing above **one** method of fixing the axles to the plastic chassis that will allow the axles to turn freely.

(4)

(iv) Use notes and sketches to show **one** method of fixing the wheels to the axles that will allow the wheels to turn freely on the axle. Explain how your method works.

*Leave blank*

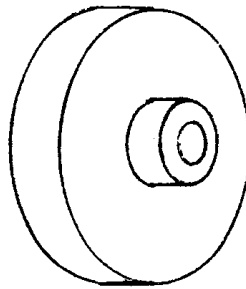

Detail of wheel

Explanation.....  
.....  
(4)

(b) Explain **two** safety issues of which the designer needs to be aware when designing toys for young children.

1 .....  
.....  
2 .....  
.....  
(4)

(c) (i) Describe **two** advantages to the environment of using plastics which are suitable for recycling.

1 .....  
.....  
2 .....  
.....  
(4)

(ii) The chassis of the toy is to be moulded in batches of 500 using a suitable plastics material that can be recycled.

*Leave blank*

Give **three** advantages of this moulding process compared with cutting the wheels from flat sheet.

1. ....

2. ....

3. ....

**(3)**

**(Total 22 marks)**

---

3. A company is designing a rack to hold CDs (compact discs) in their cases.

The specification of the CD rack is that it must:

- hold 15 single CD cases;
- allow easy selection of individual CD cases;
- be easy to clean;
- be suitable to manufacture in batches of 100.

- (a) In the spaces below, use notes and sketches to show **two** ideas for the design of the CD rack which meets this specification.

**DESIGN IDEA 1**

**DESIGN IDEA 2**

*Leave  
blank*

**(8)**

(b) Three of the specification points are given below.

Use these headings to evaluate **one** of your design ideas against the initial specification.

1. The CD rack must hold 15 single CD cases.

.....  
.....  
.....  
.....

2 The CD rack must allow easy selection of individual CDs.

.....  
.....  
.....  
.....

3 The CD rack must be suitable to manufacture in batches of 100.

.....  
.....  
.....  
.....

**(6)**

**(Total 22 marks)**

4. The drawing below shows a container for storing address cards.

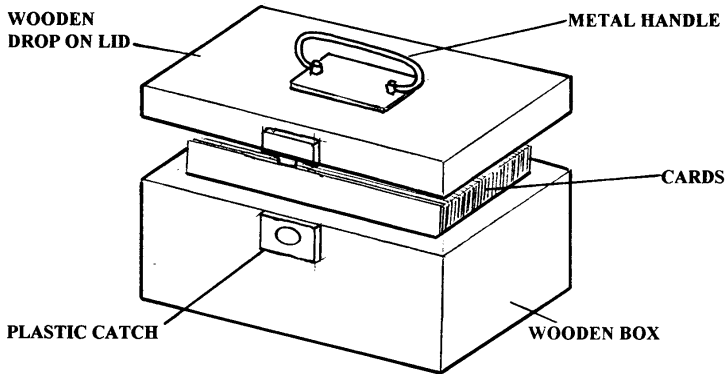

**ADDITIONAL INFORMATION**

The container is to be made of wood and will be used on an office desk.

- (a) Two specification points for the container are:
- it must hold standard address cards which measure 140mm x 90mm;
  - it must be easy to select cards from the container.

Give **three** more points of specification which could be included in the specification of this product. For each point, give a reason why it should be included.

1 .....

Reason .....

2 .....

Reason .....

3 .....

Reason .....

(6)

(b) Name the specific type of material suitable for making each of the following parts of the container.

(i) Wooden box

.....

(ii) Metal handle

.....

(iii) Plastic catch

.....

**(3)**

(c) Give **one** property associated with **one** of the materials you have named in (b) and explain how this property makes it suitable for this application.

Property .....

Explanation.....

.....

.....

**(4)**



- (d) The plastic catch is to be injection moulded in quantities of 1000.  
Complete the diagram below to show the main stages in the injection moulding process.  
The first stage has been done for you.

*Leave  
blank*

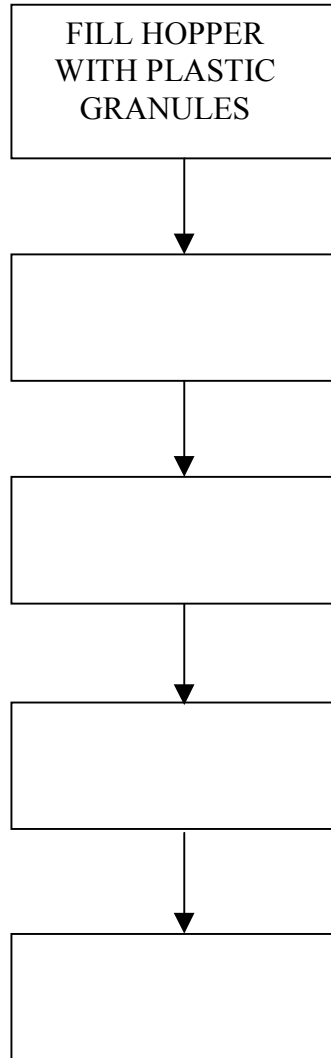

**(5)**

(e) The purpose of this desk top container is to store address cards and allow individual cards to be selected.

Describe how this design achieves its purpose.

.....

.....

.....

.....

**(4)**

**(Total 22 marks)**

---

**PAPER TOTAL 88 MARKS**

**END**

*Leave blank*



Answer ALL questions in the spaces provided.

Leave  
blank

1. The drawing below shows a container for storing address cards.

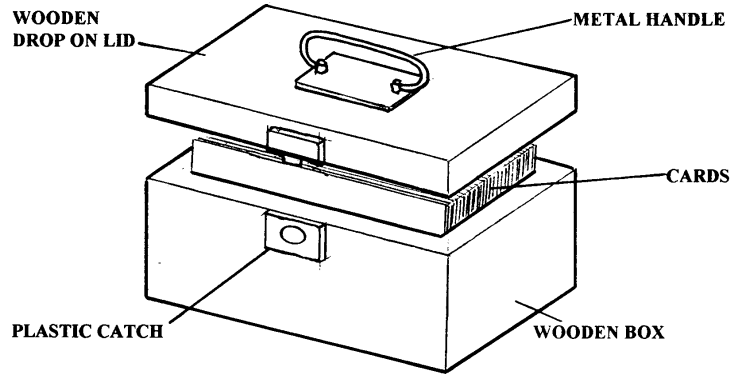

**ADDITIONAL INFORMATION**

The container is to be made of wood and will be used on an office desk.

(a) Two specification points for the container are:

- it must hold standard address cards which measure 140mm x 90mm;
- it must be easy to select cards from the container.

Give **three** more points of specification which could be included in the specification of this product. For each point, give a reason why it should be included.

1 .....

Reason .....

2 .....

Reason .....

3 .....

Reason .....

(6)

(b) Name the specific type of material suitable for making each of the following parts of the container.

(i) Wooden box

.....

(ii) Metal handle

.....

(iii) Plastic catch

.....

**(3)**

(c) Give **one** property associated with **one** of the materials you have named in (b) and explain how this property makes it suitable for this application.

Property .....

Explanation.....

.....

.....

**(4)**

- (d) The plastic catch is to be injection moulded in quantities of 1000.  
Complete the diagram below to show the main stages in the injection moulding process.  
The first stage has been done for you.

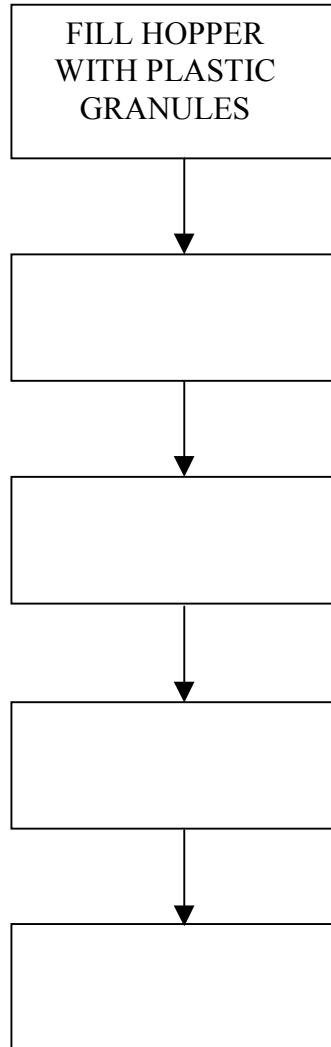

(5)

- (e) The purpose of this desk top container is to store address cards and allow individual cards to be selected.

Describe how this design achieves its purpose.

.....

.....

.....

.....

(4)

(Total 22 marks)

2. The drawing below shows a piece of metal marked out ready for drilling and shaping.

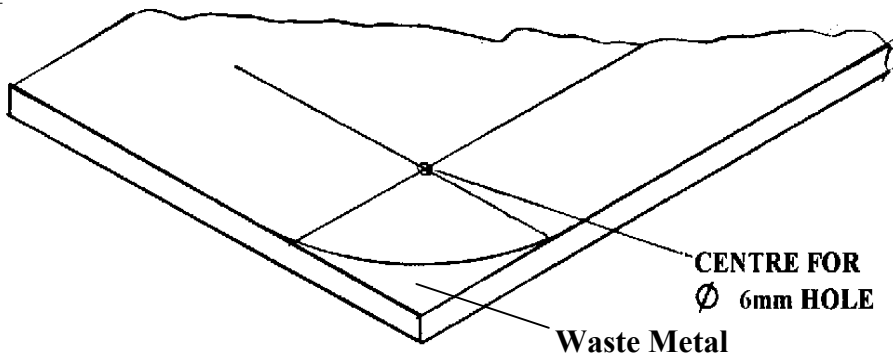

(a) (i) Add to the table below the tools used for marking out this piece of metal.

One tool has been named for you.

PROCESS	TOOL USED
<i>Mark the centre of a hole</i>	<i>Odd leg calipers</i>
<i>Punch the centre of a hole</i>	
<i>Mark radius on corner</i>	

(2)

(ii) Name **two** tools used to remove the waste metal and finish the radius.

1 .....

2 .....

(2)

(b) (i) Make a clear sketch of a pair of odd leg calipers and identify their key features.

(4)

(ii) Explain how the odd leg calipers would be used the position of the centre of the 6mm diameter hole.

.....

.....

.....

.....

.....

(3)

(c) The drawing below shows a Hole Saw.

It is to be used to make a 45mm diameter hole in a piece of acrylic measuring 300 x 65 x 3mm.

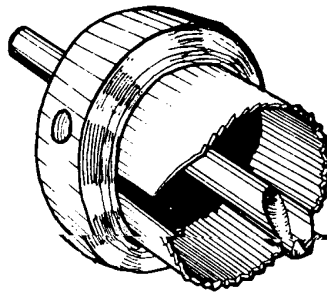

(i) Use notes and sketches to explain how the acrylic would be held securely prior to drilling on a pillar drill.

(3)



*Leave blank*

(ii) Explain why a pilot hole would be drilled in the acrylic before using the hole saw.

.....  
.....

**(2)**

(iii) Before drilling takes place, a risk assessment should be done.

Describe **three** precautions you would take before drilling the acrylic.

1 .....  
.....  
2 .....  
.....  
3 .....  
.....

**(6)**

**(Total 22 marks)**

---

3. The drawing below shows one design for a self assembly book rack made from wood effect veneered chipboard. The book rack is sold as a flat-packed self assembly item. The detail shows the knock down (KD) fittings supplied with the book rack.

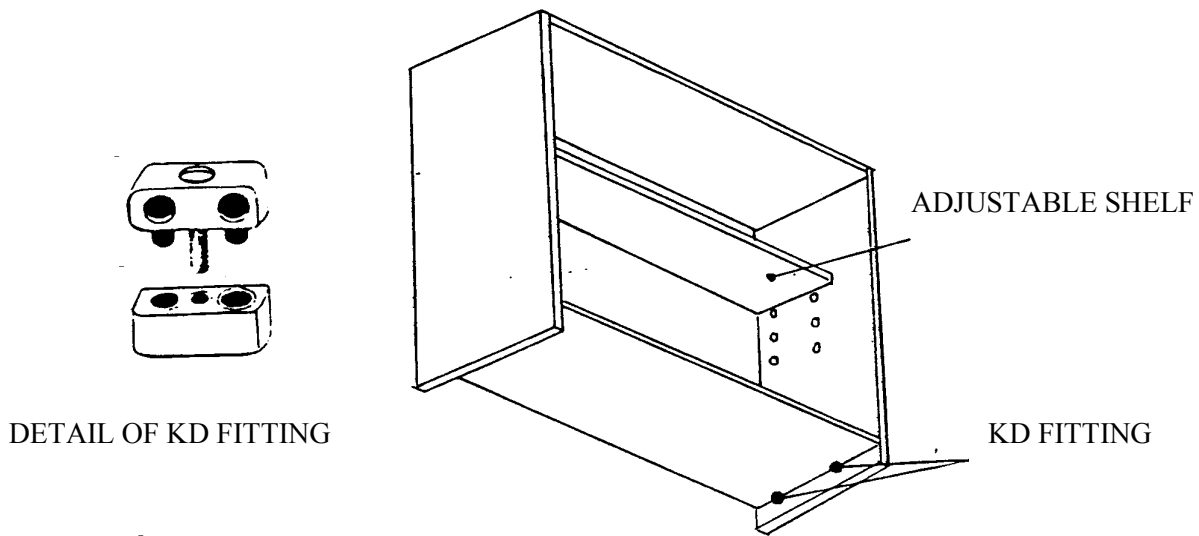

- (a) The KD fitting is manufactured from a plastic material using the injection moulding process.

- (i) Name a suitable plastic material for the KD fitting

..... (1)

- (ii) Give **three** reasons for the manufacturer choosing injection moulding rather than machining the KD fitting from a solid piece of material.

1. ....

2. ....

3. ....

(3)

- (b) (i) Use an annotated sketch to show how the KD fitting is joined to one side and the base of the book rack.

(3)

(ii) Explain why this fitting is called a “Knock Down” fitting.

.....  
.....

(2)

(c) The shelf position can be adjusted to three pre-drilled heights.

Make a clear drawing to show a suitable fitting that can be inserted in any of the pre-drilled holes to make the shelf height adjustable.

(2)

(d) Many products are designed with built-in obsolescence.

Describe **three** effects that built-in obsolescence would have on the design of a product.

1 .....

.....

2 .....

.....

3 .....

.....

(6)

(e) Explain how the self-assembly book rack design makes use of materials in an environmentally friendly way.

.....

.....

.....

.....

.....

.....

**(5)**

**(Total 22 marks)**

---

*Leave  
blank*

**BLANK PAGE**

**TURN OVER FOR QUESTION 4**

4. A company is designing a music stand to be used on a table top.

The specification of the music stand is that it must:

- fold flat when not in use;
- hold sheet music open;
- be robust yet lightweight;
- be suitable for production in large scale quantities.

- (a) In the spaces below, use notes and sketches to show **two** ideas for the design of the music stand which meets this specification.

**DESIGN IDEA 1**

**DESIGN IDEA 2**

*Leave  
blank*

**(8)**





**DESIGN & TECHNOLOGY: RESISTANT MATERIALS TECHNOLOGY (1973/2F)**  
**FULL COURSE FOUNDATION TIER MARK SCHEME**

Qu.	Prt Qu.	Sub Qu.	Detailed Possible Answers	Mark Alloc.	Sub. Total
1.	(a)	(i)	Name: Screwdriver, Name: Engineer's Hammer, Name: Try Square Name: Countersunk bit Name: CNC Lathe	5x1	
		(ii)	Use: inserting screws, Use: striking punches/ forming metal/ peining rivets etc, Use: measuring and marking right angles. Use: producing a countersunk recesses Use: turning materials	5x1	(10)
	(b)	(i)	Rivet drawn with round head	1 1	(2)
		(ii)	Form dome on the rivet with hammer Mention of use of rivet set Mention of paper or similar to give suitable loose joint	1 1 1	(3)
	(c)		Grip nail and pull from wood Mention use as a lever Mention of use of wooden pad to protect surface	1 1 1	(3)
	(d)	(i)	Suitable description eg. Item is pre-manufactured and is ready for use	2x1	(2)
		(ii)	Two advantages e.g. saves time, cost of manufacturing/ tooling, consistent quality/ assurance	2x1	(2)
					(22)
2	(a)	(i)	Material for axles, e.g. steel, aluminium, dowel	2x1	(2)
		(ii)	Material for wheels e.g. acrylic, nylon	1	(1)
		(iii)	Clear sketch of suitable axle fixing with notes hold securely, alignment, angle free to turn,. axle should not slip.	4x1	(4)
		(iv)	Sketch to show wheel held securely on axle with notes, e.g. crimped end, cap nut, threaded. Explanation	2 2	(4)

Qu.	Prt Qu.	Sub Qu.	Detailed Possible Answers	Mark Alloc.	Sub. Total
	<b>(b)</b>		Explanation which makes reference to 2 safety issues e.g. easily cleaned, non toxic materials, no small parts, no pull off parts, no sharp parts	<b>2x2</b>	<b>(4)</b>
	<b>(c)</b>	<b>(i)</b>	Mention of issues connected with recycling e.g. no extra raw materials used, less pollution, less land fill space required	<b>2x2</b>	<b>(4)</b>
		<b>(ii)</b>	3 reasons e.g possible less waste, cuts costs and disposal, discarded mouldings can be recycled in factory	<b>3x1</b>	<b>(3)</b>
					<b>(22)</b>
<b>3</b>	<b>(a)</b>		<b>DESIGN IDEA 1</b> Each point of specification resolved in design (fully = 2, partly = 1)	<b>4x2</b>	<b>(8)</b>
			<b>DESIGN IDEA 2</b> Each point of specification resolved in design (fully = 2, partly = 1)	<b>4x2</b>	<b>(8)</b>
	<b>(b)</b>		Each point clearly evaluated (fully = 2, partly = 1)	<b>3x2</b>	<b>(6)</b>
					<b>(22)</b>
<b>4</b>	<b>(a)</b>		Accept any three relevant points of specification and reasons eg Point: must be lightweight Reason: to ensure it is portable Point: must be easy to clean Reason: may become dusty/dirty Point: must be aesthetically pleasing Reason: needs to fit in with existing environment	<b>6x1</b>	<b>(6)</b>
	<b>(b)</b>	<b>(i)</b>	Material for box e.g. oak, mahogany, beech, pine, MDF	<b>1</b>	<b>(3)</b>
		<b>(ii)</b>	Material for handle e.g. steel, aluminium (accept others)	<b>1</b>	
		<b>(iii)</b>	Material for catch, e.g. HIP, PVC (accept others)	<b>1</b>	
	<b>(c)</b>		1 property suitable for selected material given, e.g. easy to clean, durable, light, finishes well Explanation of property ref application/ material .g. plastic catch self-lubrication and can fasten/ unfasten many times without maintenance	<b>1+3</b>	<b>(4)</b>
	<b>(d)</b>		4 stages for IJ moulding, e.g. <i>place mould</i> , heat granules, inject plastic, allow soak time, remove mould, <i>remove moulding</i> Correct sequence	<b>4x1</b>  <b>1</b>	<b>(5)</b>

Qu.	Prt Qu.	Sub Qu.	Detailed Possible Answers	Mark Alloc.	Sub. Total
	(e)		Fitness for purpose e.g. the container is shallow/ there is sufficient clearance around to allow easy access to cards, the lid has sufficient depth to cover cards when closed, produced in large batches it will be relatively cheap, production process will ensure they are all identical	2x2	(4)
					(22)
			<b>TOTAL FOR PAPER 88 MARKS</b>		

**DESIGN & TECHNOLOGY: RESISTANT MATERIALS TECHNOLOGY (1973/2H)**  
**FULL COURSE HIGHER TIER MARK SCHEME**

Qu.	Prt Qu.	Sub Qu.	Detailed Possible Answers	Mark Alloc.	Sub. Total
1	(a)		Accept any three relevant points of specification and reasons eg Point: must be lightweight Reason: to ensure it is portable Point: must be easy to clean Reason: may become dusty/dirty Point: must be aesthetically pleasing Reason: needs to fit in with existing environment	6x1	(6)
	(b)	(i)	Material for box e.g. oak, mahogany, beech, pine, MDF	1	(3)
		(ii)	Material for handle e.g. steel, aluminium (accept others)	1	
		(iii)	Material for catch, e.g. HIP, PVC (accept others)	1	
	(c)		1 property suitable for selected material given, e.g. easy to clean, durable, light, finishes well Explanation of property ref application/ material .g. plastic catch self-lubrication and can fasten/ unfasten many times without maintenance	1+3	(4)
	(d)		4 stages for IJ moulding, e.g. <i>place mould</i> , heat granules, inject plastic, allow soak time, remove mould, <i>remove moulding</i> Correct sequence	4x1  1	(5)
	(e)		Fitness for purpose e.g. the container is shallow/ there is sufficient clearance around to allow easy access to cards, the lid has sufficient depth to cover cards when closed, produced in large batches it will be relatively cheap, production process will ensure they are all identical	2x2	(4)
					(22)
2	(a)	(i)	Centre/ dot punch, dividers	2x1	(2)
		(ii)	Hacksaw, file	2x1	(2)
	(b)	(i)	Identifiable odd leg caliper drawn Hardened scriber, odd leg	2x2	(4)
		(ii)	Odd leg held against edge of metal and line drawn Process repeated on second edge with same setting Intersection of lines is centre	3x1	(3)
	(c)	(i)	Drawing showing sheet clamped by some means to the drill table, soft material underneath, protection between clamp & acrylic	3x1	(3)

Qu.	Prt Qu.	Sub Qu.	Detailed Possible Answers	Mark Alloc.	Sub. Total
		(ii)	Pilot hole more accurate Guide large but through in alignment	2x1	(2)
		(iii)	3 points e.g. all power to machine isolated while changing tools, securely clamped workpiece, select the correct slow speed, use a sharp drill	3x2	(6)
					(22)
<b>3</b>	<b>(a)</b>	<b>(i)</b>	Nylon	1	(1)
		<b>(ii)</b>	Any 3 reasons from Repeatability, low cost, cost effective, Reduces waste, speed	3x1	(3)
	<b>(b)</b>	<b>(i)</b>	Clear sketch with notes to show sequence Locate and screw component to one half of joint, then second half attached to first, attach second half to bottom	3x1	(3)
		<b>(ii)</b>	Machine screw which joins two parts together is only component which needs to be removed.	2x1	(2)
	<b>(c)</b>		Suitable shelf fitting drawn Capable of repositioning	1 1	(2)
	<b>(d)</b>		Description which makes reference to: Mass produced from cheap materials, fashionable, throwaway	3x2	(6)
	<b>(e)</b>		Veneered board saves timber, chipboard ground uses more of felled tree, flat pack requires less packaging, less storage space, less transport costs.	5x1	(5)
					(22)
<b>4</b>	<b>(a)</b>		<b>DESIGN IDEA 1</b> Each point of specification resolved in design (fully = 2, partly = 1)	4x2	(8)
			<b>DESIGN IDEA 2</b> Each point of specification resolved in design (fully = 2, partly = 1)	4x2	(8)
	<b>(b)</b>		Each point justified in evaluation (fully = 2, partly = 1)	3x2	(6)
					(22)
			<b>TOTAL FOR PAPER 88 MARKS</b>		

**DESIGN & TECHNOLOGY: RESISTANT MATERIALS TECHNOLOGY (1973)  
SPECIFICATION GRID**

<b>PAPER 2F</b>				
<b>Quest</b>	<b>Assessment objective tested</b>	<b>Content covered by question</b>	<b>Question style/type</b>	<b>Marks</b>
1	AO1	Preparing, processing and finishing materials and manufacturing commercial products	Structured question on a theme.	<b>Total 22</b>
2	AO1 + AO3	Classification and selection of materials and components.  Design and market influence, parts (i) and (ii) not covered in question 3.	Structured question on a theme.	<b>11 + 11 Total 22</b>
3	AO2	Design question.  This question accounts for <b>all</b> 10% of designing marks.	Design question – candidates design a product from a specification and evaluate against the specification.	<b>Total 22</b>
4	AO3	Design and market influence, part (iii).	Product analysis – candidates are asked to analyse a product following the analysis process.	<b>Total 22</b>
<b>PAPER 2H</b>				
<b>Quest</b>	<b>Assessment objective tested</b>	<b>Content covered by question</b>	<b>Question style/type</b>	<b>Marks</b>
1	AO3	Design and market influence, part (iii).	Product analysis – candidates are asked to analyse a product following the analysis process.	<b>Total 22</b>
2	AO1	Preparing, processing and finishing materials and manufacturing commercial products	Structured question on a theme.	<b>Total 22</b>
3	AO1 + AO3	Classification and selection of materials and components.  Design and market influence, parts (i) and (ii) not covered in question 3.	Structured question on a theme.	<b>11 + 11 Total 22</b>
4	AO2	Design question.  This question accounts for <b>all</b> 10% of designing marks.	Design question - candidates design a product from a specification and evaluate against the specification.	<b>Total 22</b>

Further copies of this publication are available from  
Edexcel Publications, Adamsway, Mansfield, Notts, NG18 4FN

Telephone 01623 467467  
Fax 01623 450481

Order Code **UG 009336**  
Summer 2000

For more information on Edexcel qualifications please contact our  
Customer Response Centre on 0870 240 9800  
or email: [enquiries@edexcel.org.uk](mailto:enquiries@edexcel.org.uk)  
or visit our website: [www.edexcel.org.uk](http://www.edexcel.org.uk)

Edexcel Foundation is a registered charity and a company limited  
by guarantee. Registered in England No. 1686164

***Edexcel***  
*Success through qualifications*

