

Specimen for 2007

**International General Certificate of Secondary Education**

MARK SCHEME

MAXIMUM MARK: 75

SYLLABUS/COMPONENT: 0445/02

DESIGN AND TECHNOLOGY

Communication



UNIVERSITY of CAMBRIDGE  
International Examinations

[www.Students-Resource.com](http://www.Students-Resource.com)

<b>A1.</b>	Hexagonal hole 30 side	2	
	Diamond hole 50 x 60	2	
	Equilateral triangle hole 50 side	2	
	Semi-circular hole Ø60	2	
	Rectangular hole 50 x 40	1	<b>9</b>
<b>A2.</b>	Accuracy and proportion of:		
	K	1	
	I	1	
	N	1	
	G	1	
	Height	1	
	Spacing	1	<b>6</b>
<b>A3</b>	<b>(i)</b> Width	1	
	Overall Height	1	
	Height to top of shoulder	1	
	30 x 5 recess	1	
	R15 curve	1	
	Thickness on curve	1	<b>6</b>
	<b>(ii)</b> Thick line applied:		
	All outside edges ( Pr 1-2 )	2	
	Top edge of 30 x 5 recess	1	
	Back shoulder	1	<b>4</b>
			<b>25</b>
<b>B4</b>	<b>(a)</b> Wheel:		
	width	1	
	height	1	
	angle	1	
	ends	1	
	position	1	<b>5</b>
	<b>(b)</b> semi-octagon:		
	length of side 48 / 50 +/- 2mm	1	
	construction 1 + 1	2	
	accuracy of semi-octagon	2	<b>5</b>
	<b>(c)</b> semi-ellipse :		
	correct orientation	1	
	suitable construction 1 + 1	2	
	accuracy of construction	1	
	outline ( constructed )	1	<b>5</b>
	<b>(d)</b> Two inner arcs:		
	joins to semi-circle	1	
	construction 1 + 1	2	
	R55	1	
	accurate line ( even if not constructed)	1	<b>5</b>

(e)	construction evident	2	
	overall height of rectangle	1	
	triangle added	1	
	circle touching sides	1	5
			25

**B5 (a) EV**

1 <sup>st</sup> angle projection	1	
in line from plan	1	
overall height	1	
angle of top	1	
position of slot	1	
size of slot	1	6

**PLAN**

pentagon correct size	1	
orientation	1	
accuracy ( Pr 1-2 )	2	4

**(b) Development Top:**

T/L of top taken from EV	1	
projection	1	
width	1	
accuracy ( Pr 1-2 )	2	5

**Development sides:**

two long sides (2 x 1 )	2	
two short sides (2 x 1 )	2	
slot position	1	
slot size	1	6

**(c) sketch of support**

looks like a pentagon	1	
satisfies brief	1	
has fold down flaps	1	
quality of sketch (0 - 1)	1	4

**25**

**BLANK PAGE**

---

**The following worked answers represent a typical candidate answer giving the style of response expected to gain full marks and not necessarily a 100% perfect answer.**

**Section A**

Answer **all** questions in this section.

**A1** A child's shape sorter box is shown below with **one** of the six shape holes drawn in position.

The full-size plan view of the shape sorter box, with one shape completed, is drawn to the right.

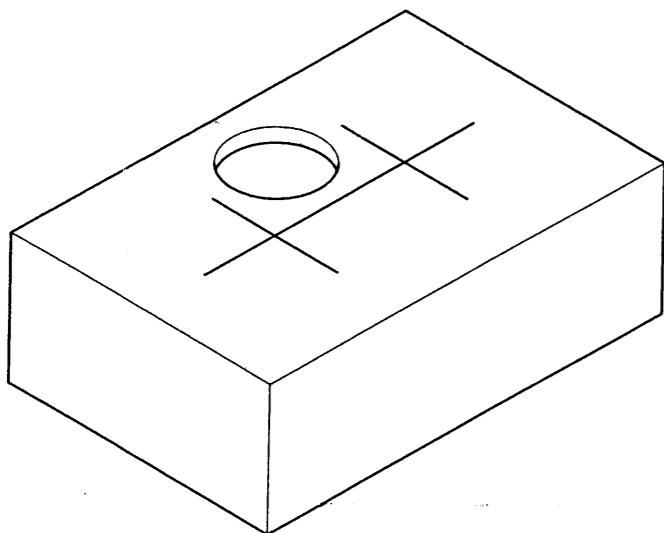

Complete the full-size plan view of the shape sorter box by drawing in the spaces provided:

- a regular **hexagon** side 30;
- a **diamond** 50 x 60 diagonals;
- a **rectangle** hole 50 x 40;
- a **semi-circle** Ø60;
- an equilateral **triangle** side 50.

[9]

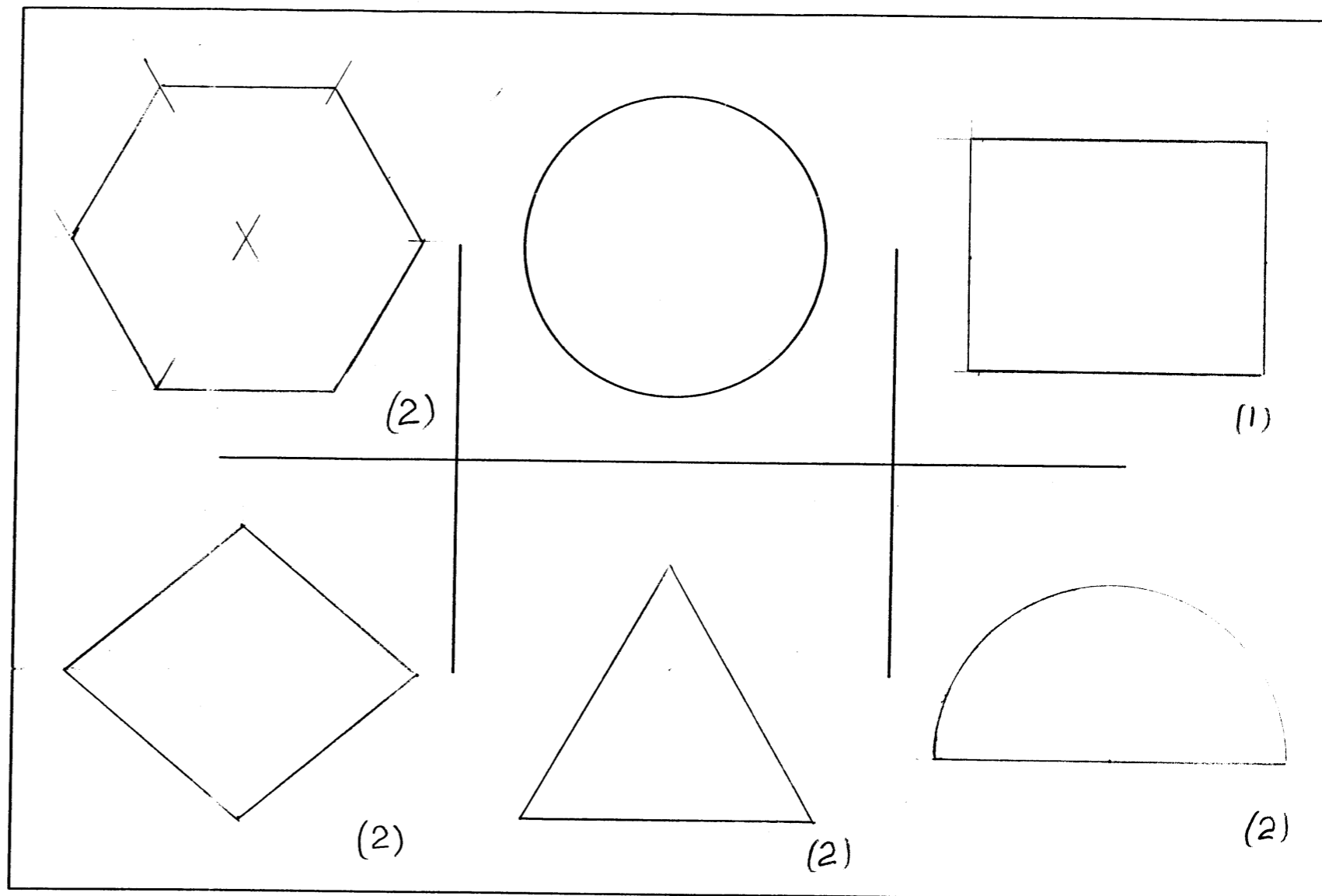

Plan View of shape sorter box

**A2** An incomplete road sign for PARKING is drawn to the right.

Complete the road sign by adding the **four** remaining letters. All the letters must be the same height and style as those given. [6]

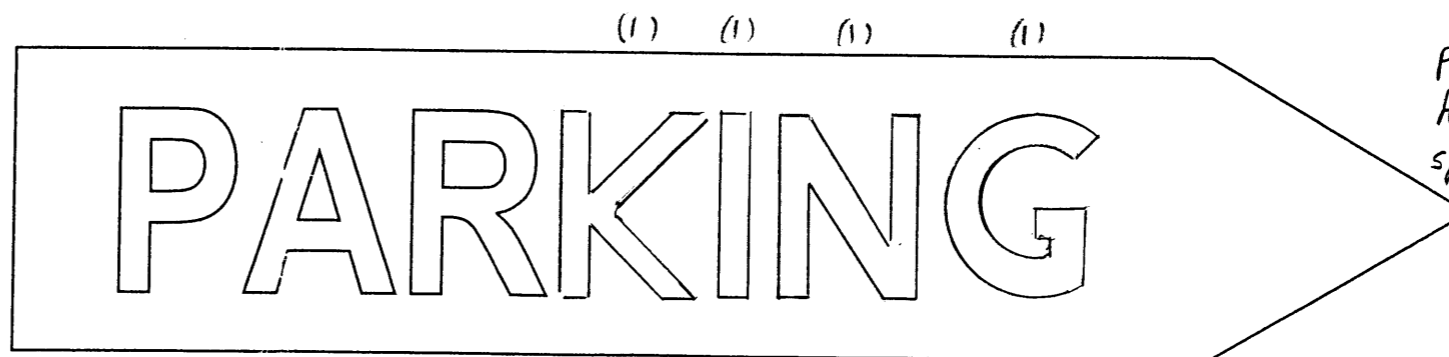

proportion of:  
height (1)  
spacing (1)

**0445/02** Worked Answers for  
**0446/02** Specimen Paper 2007 **1 hour**  
© UCLES 2005 SJF3907/CG T01801/2

Centre Number .....

Candidate's Number .....

Candidate's Name .....

For  
Examiner's  
use



support post

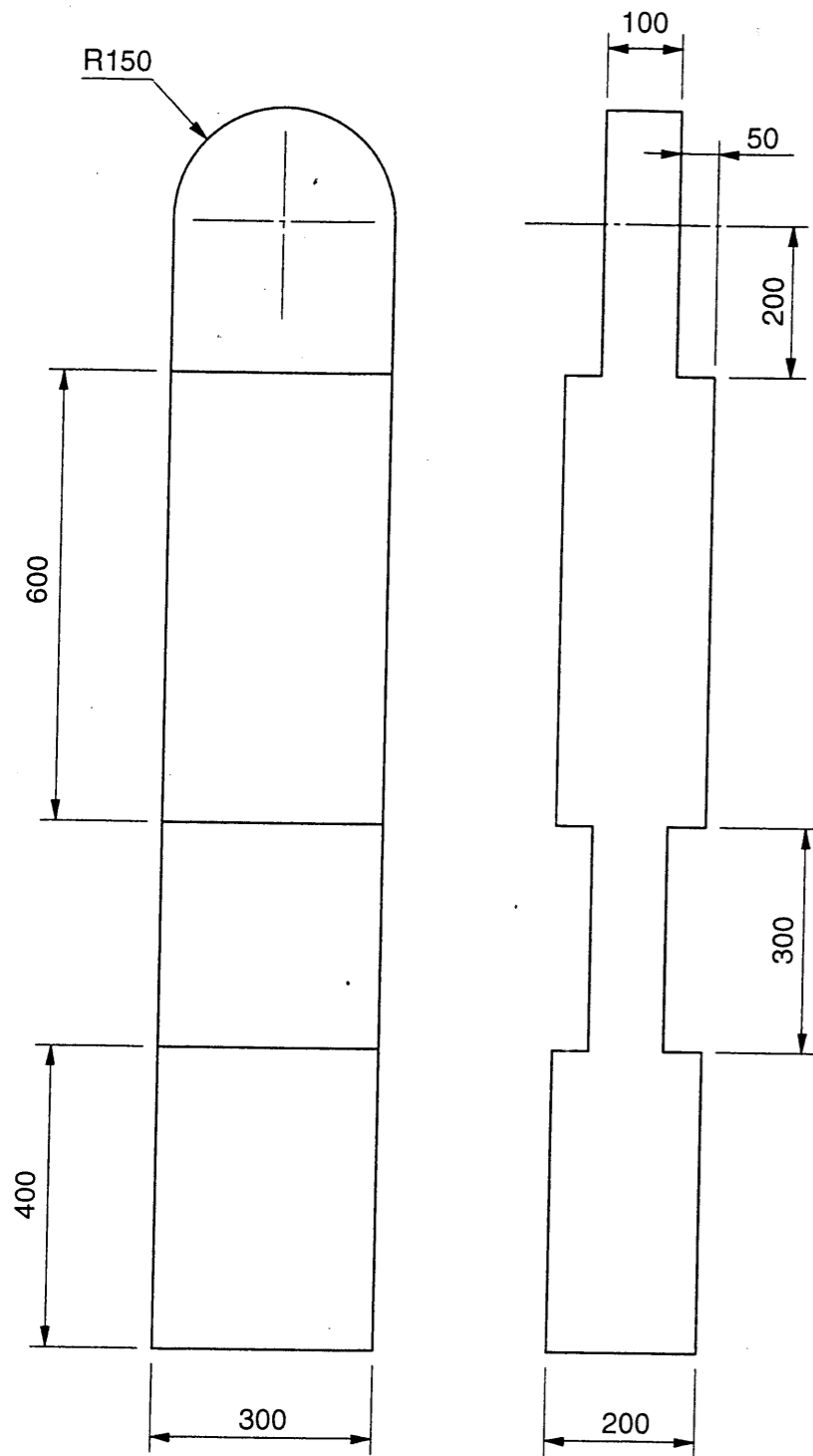

scale 1:10

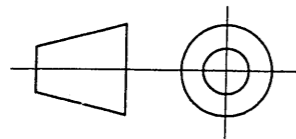

**A3** A support post for a temporary barrier is drawn to a scale of 1:10 in the orthographic views given to the left.

In the space given to the right:

- (a) Sketch freehand, an isometric view of the support post. The sketch should be to the same scale and all sizes should be taken from the given orthographic views. [6]
- (b) Apply the thick and thin line technique to enhance your isometric sketch. [4]

Isometric sketch

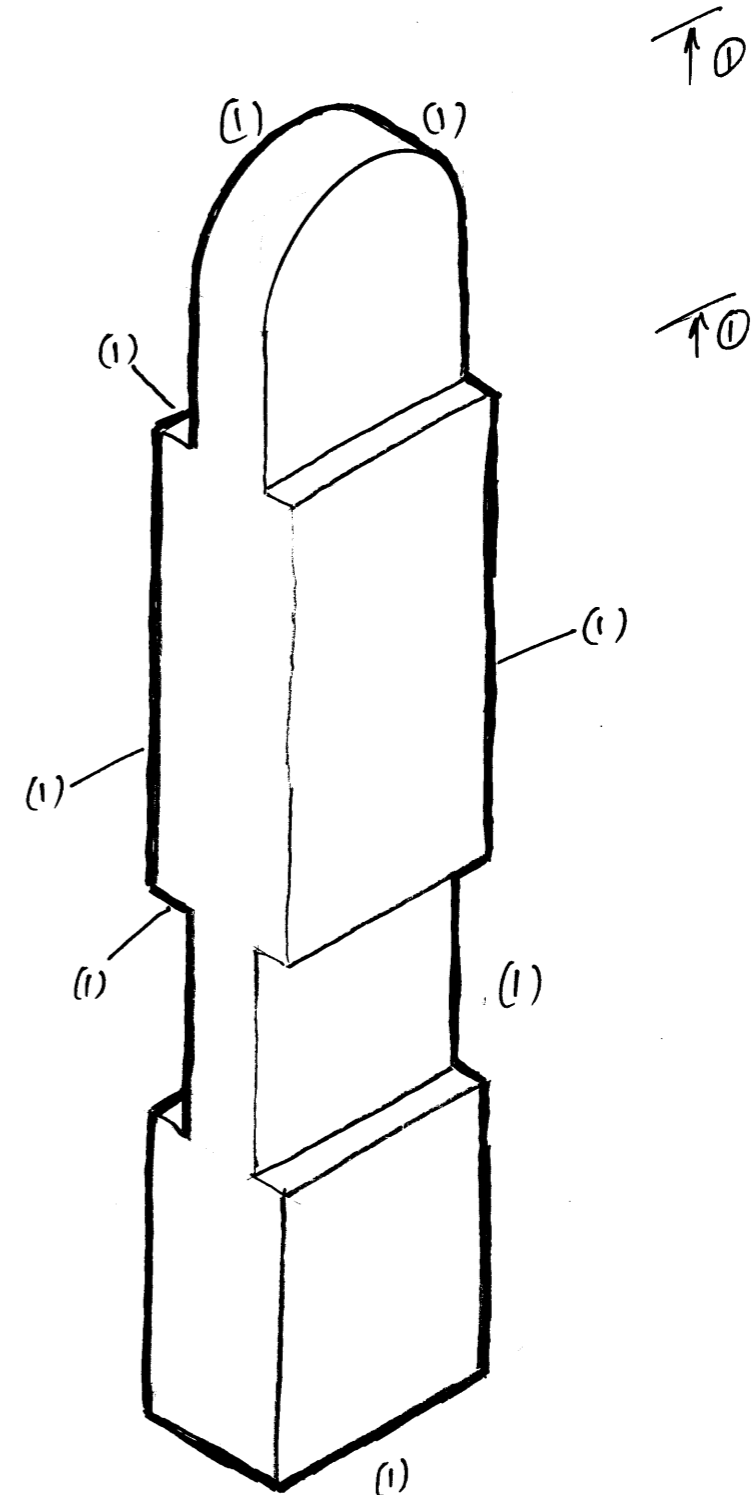

**Section B**

Answer **either** question **B4** or question **B5**.

**B4** A National car museum uses an illustration of an old car as its logo, as shown in the sketch below.

Complete the full-size drawing of the logo by:

- (a) drawing the other wheel; [5]
- (b) drawing the semi-octagon; [5]
- (c) constructing the semi-ellipse; [5]
- (d) constructing the two R55 inner arcs; [5]
- (e) drawing the headlamp in position on the logo by enlarging the given drawing. [5]

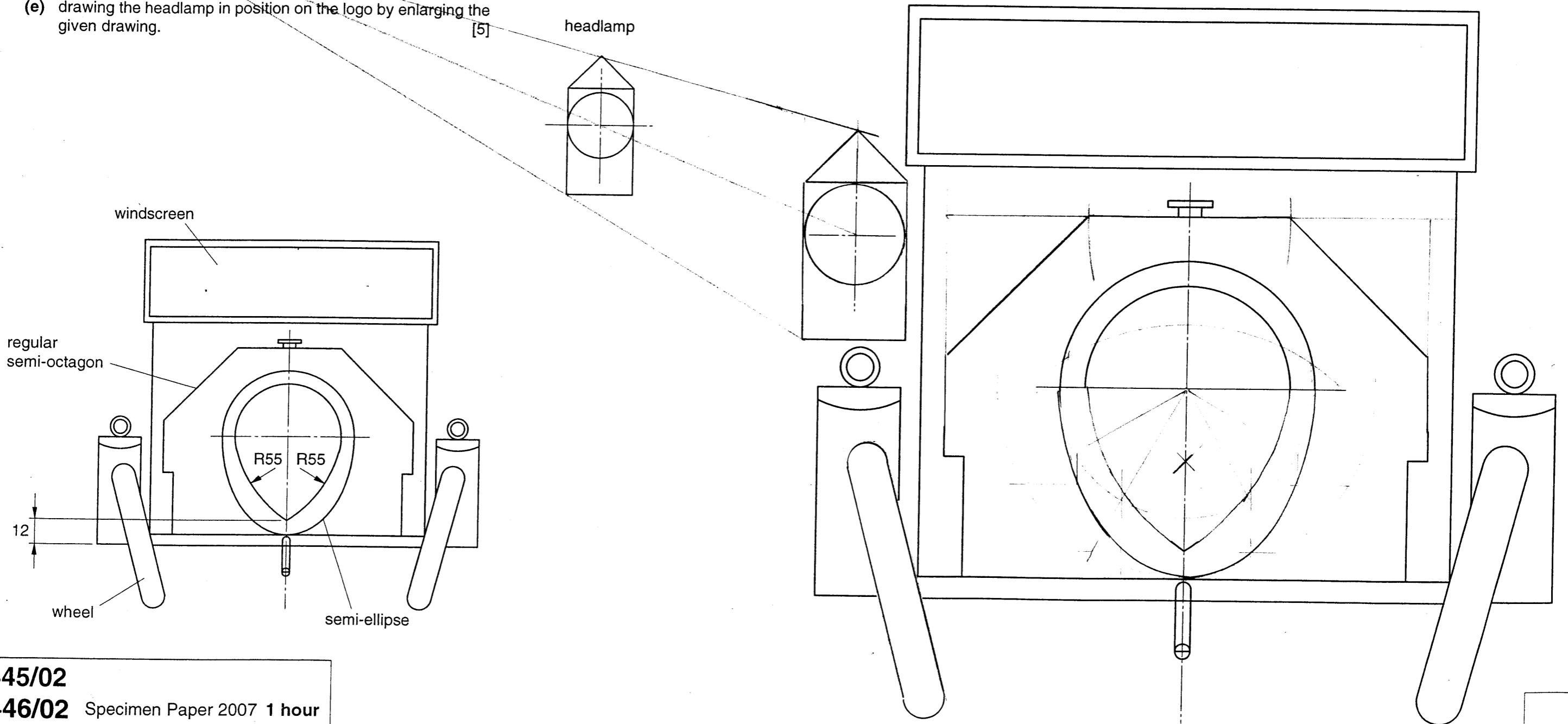

**0445/02**  
**0446/02** Specimen Paper 2007 1 hour  
 © UCLES 2005 SJF3907/CG T01801/2

Centre Number .....

Candidate's Number .....

Candidate's Name .....

Answer either question B4 or question B5.

**B5** The sketch below shows a thin card packaging for a cosmetic product. The packaging has a window so that customers can see the product.

In the spaces indicated:

- (a) draw to a scale of 1:2 in first angle orthographic projection, the view **EV** and the **PLAN** of the dispenser. [10]
- (b) construct, to the same scale, a one-piece development of the packaging. Do not draw the base or any gluing or other flaps. Ignore the thickness of the card. [11]
- (c) sketch a simple support, also made from thin card, which will be inserted in the packaging so that the base of the cosmetic product will be level with the edge **T**. [4]

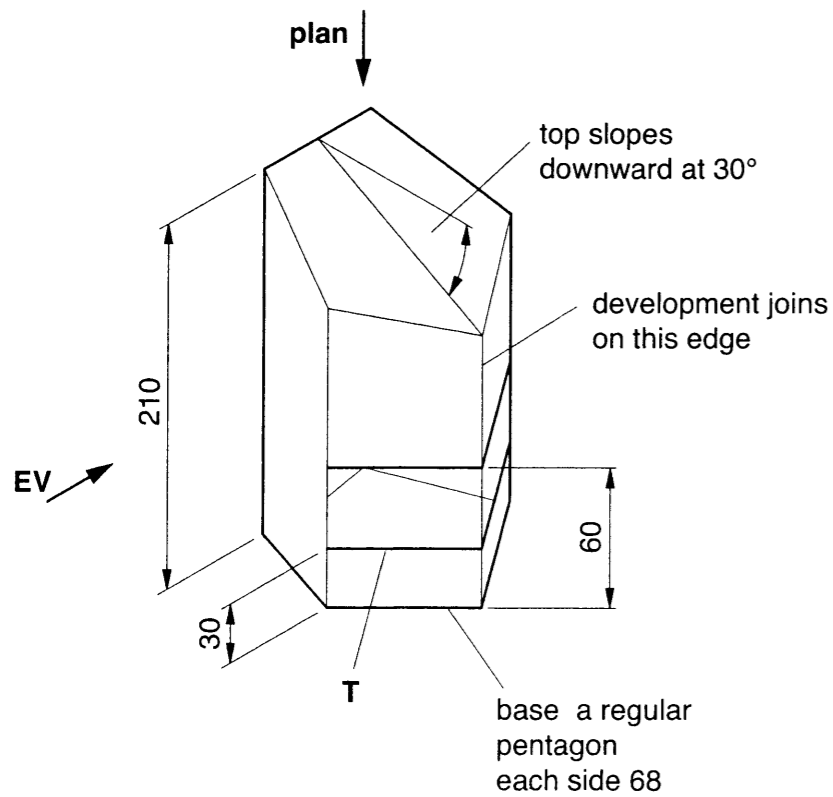

Answer part (a) here

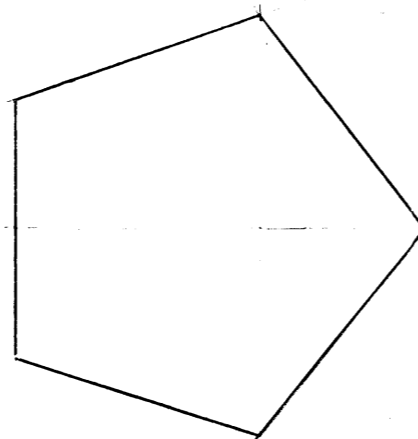
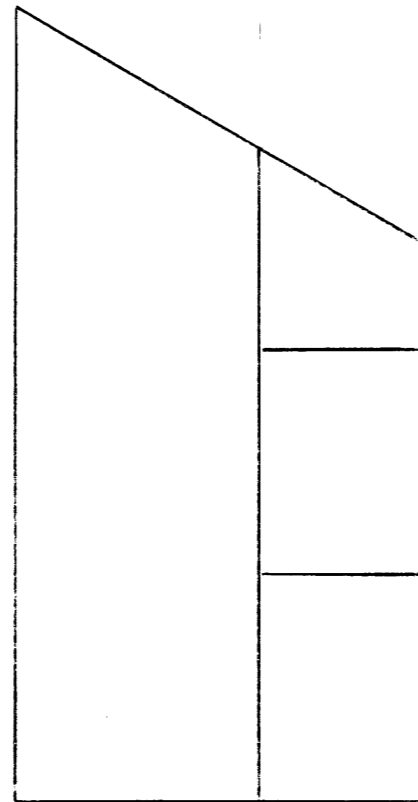

Answer part (b) here

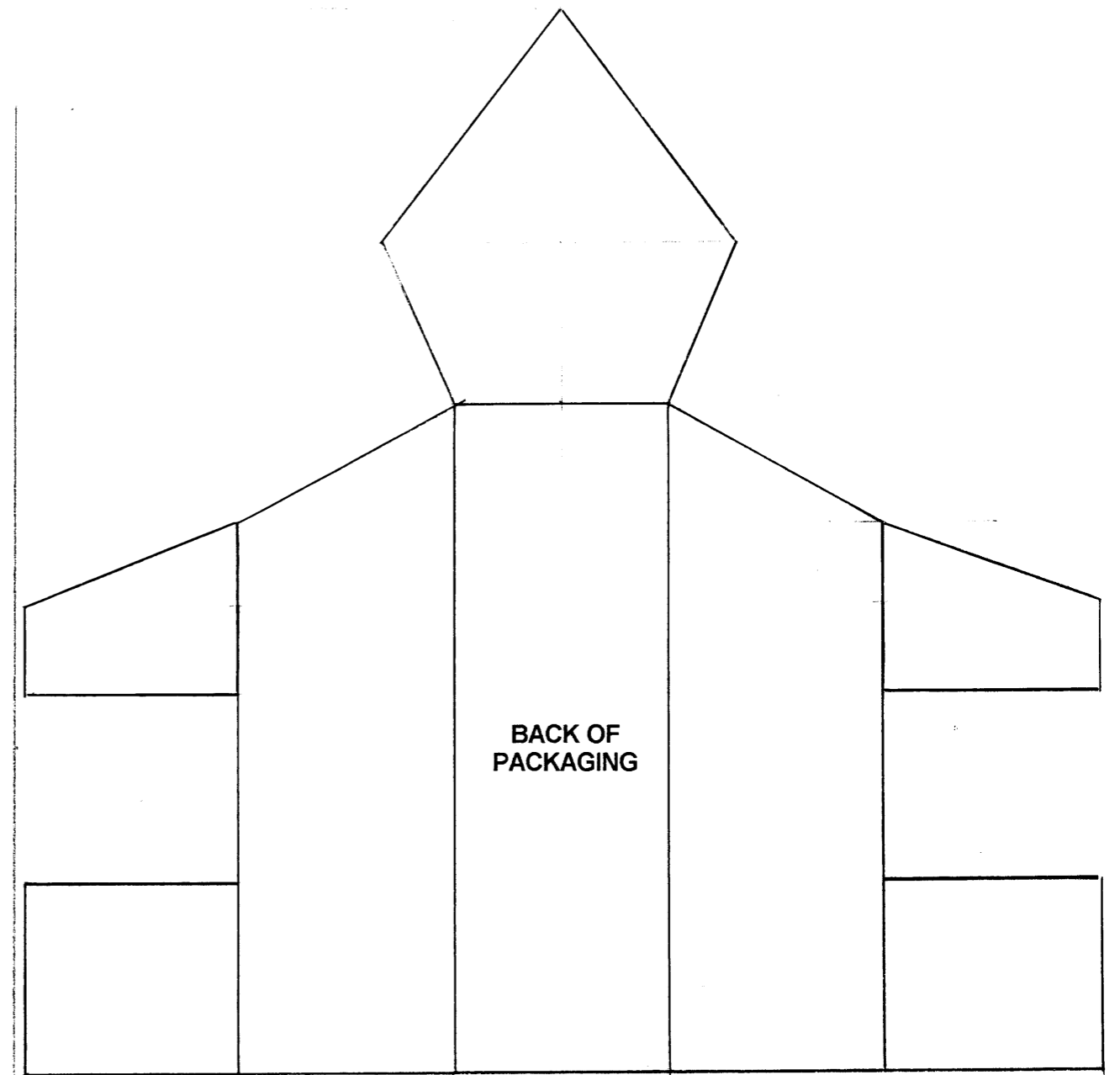

Answer part (c) here

