



UNIVERSITY OF CAMBRIDGE INTERNATIONAL EXAMINATIONS
International General Certificate of Secondary Education

CANDIDATE
NAME

CENTRE
NUMBER

--	--	--	--	--

CANDIDATE
NUMBER

--	--	--	--	--

* 0 1 2 4 9 5 6 1 4 3 *

DESIGN AND TECHNOLOGY

0445/31

Paper 3 Resistant Materials

May/June 2013

1 hour

Candidates answer on the Question Paper.

No Additional Materials are required.

To be taken together with Paper 1 in one session of 2 hours 15 minutes.

READ THESE INSTRUCTIONS FIRST

Write your Centre number, candidate number and name on all the work you hand in.

Write in blue or black pen.

You may use a soft pencil for any diagrams, graphs or rough working.

Do not use staples, paper clips, highlighters, glue or correction fluid.

DO NOT WRITE IN ANY BARCODES.

Section A

Answer **all** questions in this section.

Section B

Answer **one** question in this section.

You may use a calculator.

The total of the marks for this paper is 50.

The number of marks is given in brackets [] at the end of each question or part question.

For Examiner's Use	
Section A	
Section B	
Total	

This document consists of **15** printed pages and **1** blank page.



Section A

Answer **all** questions in this section.

- 1 Fig. 1 shows a greenhouse with a frame made from aluminium.

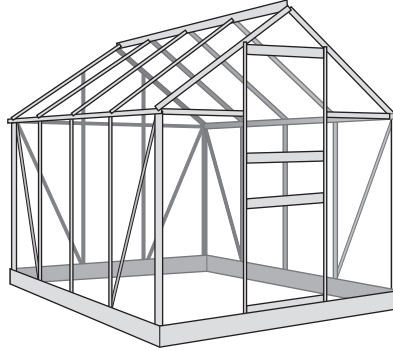

Fig. 1

Give **two** reasons why aluminium is a suitable material for the greenhouse frame.

- 1
- 2 [2]

- 2 Fig. 2 shows a piece of 5 mm thick mild steel.

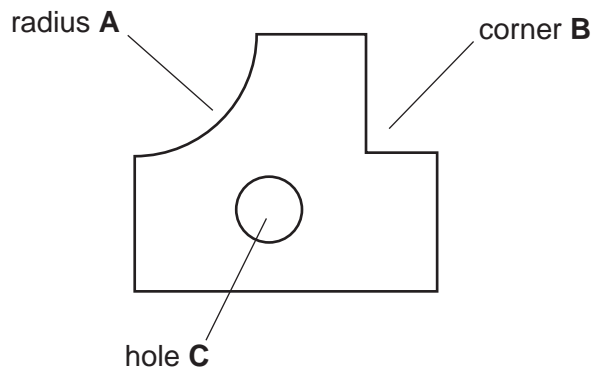



Fig. 2

Name a specific type of file used to shape:

- radius **A**
- corner **B**
- hole **C** [3]

3 State what is meant by each safety symbol shown below.

(a)  [1]

(b)  [1]

4 Complete the drawing below to show a rebate.

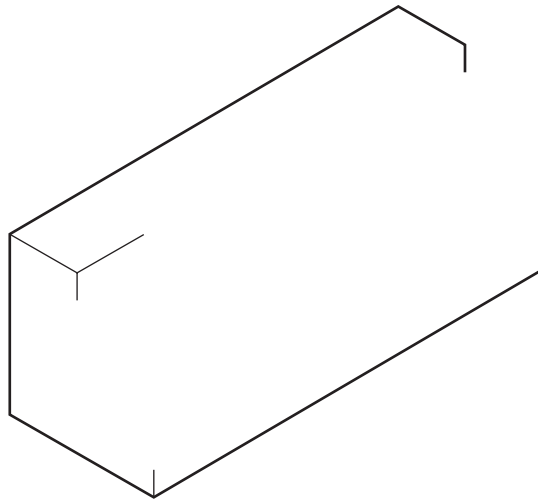

[3]

5 Complete the table below by naming each tool and giving a specific use.

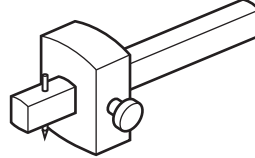
Tool	Name	Specific use
		
		

[4]

6 Fig. 3 shows sheet metal being cut in a vice.

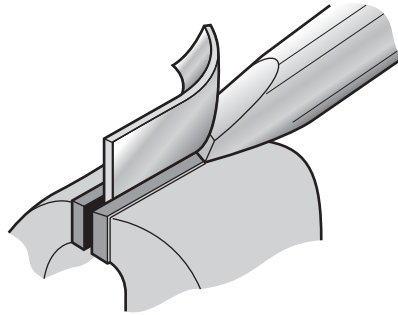

Fig. 3

(a) Name the tool shown cutting the sheet metal in the vice.

..... [1]

(b) Name a different tool that could be used to cut sheet metal.

..... [1]

7 Fig. 4 shows a garden chair made from plastic.



Fig. 4

Give **two** advantages to consumers of garden chairs made from plastic rather than wood.

1

2 [2]

8 Fig. 5 shows two pieces of 6 mm thick manufactured board.

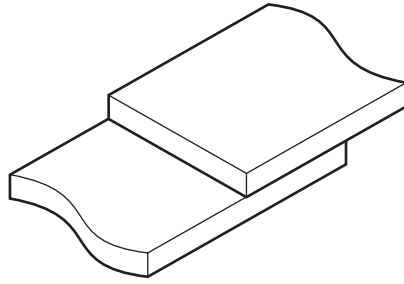

Fig. 5

Name **two** suitable adhesives that could be used to join the pieces of manufactured board.

1

2 [2]

9 Fig. 6 shows a joint marked out on solid wood.

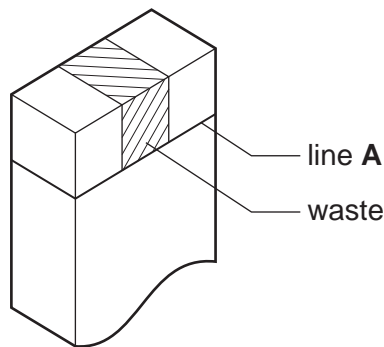

Fig. 6

Name an appropriate tool used to:

(a) mark out line A;

..... [1]

(b) remove the waste.

..... [1]

10 Fig. 7 shows a metric micrometer and a close-up view of the sleeve and thimble.

For
Examiner's
Use

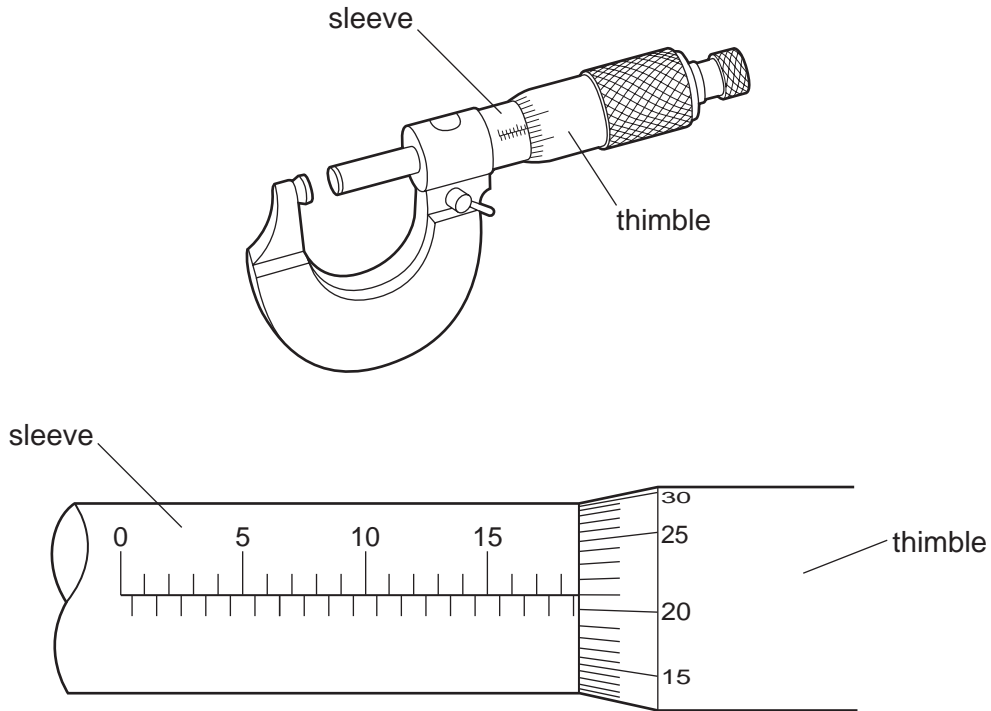

Fig. 7

State the exact reading shown to one hundredth of a mm (0.01 mm).

..... [3]

Section B

Answer **one** question in this section.

11 Fig. 8 shows views of a table designed as flat-pack for self-assembly.

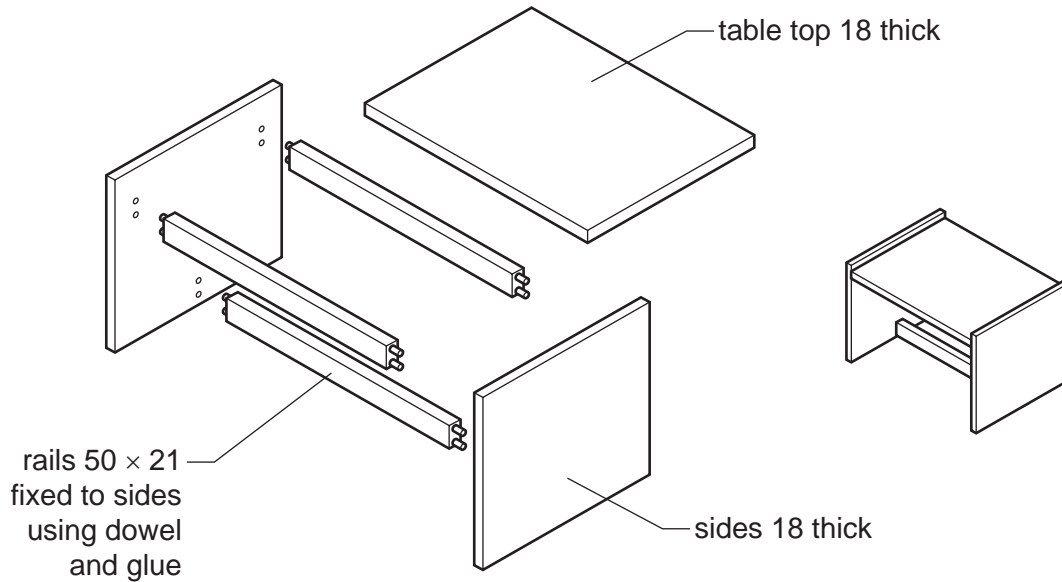

Fig. 8

(a) (i) Give **two** advantages of using manufactured board rather than solid wood for the table top.

1

2 [2]

(ii) Give **one** disadvantage of using manufactured board rather than solid wood for the table top.

..... [1]

(b) Use sketches and notes to show how **one** rail could be screwed to the underside of the table top.

[3]

- (c) (i)** Use sketches and notes to show how the holes in the rail and side could be marked out so that they line up accurately.

[4]

- (ii)** Use sketches and notes to show a permanent construction, other than a dowel joint, that could be used to fix one rail to a side. Additional materials may be used.

[4]

- (iii)** Use sketches and notes to show how a KD (knock-down) fitting could be used to join one rail to a side.

[3]

(d) Give **two** benefits of using an electric sander to prepare the surface of the table top to take a finish.

1

2 [2]

(e) Use sketches and notes to produce a set of instructions showing consumers how to assemble the parts of the table.

[6]

12 Fig. 9 shows a child's toy. The tray is made from vacuum formed plastic and the shapes are made from solid wood.

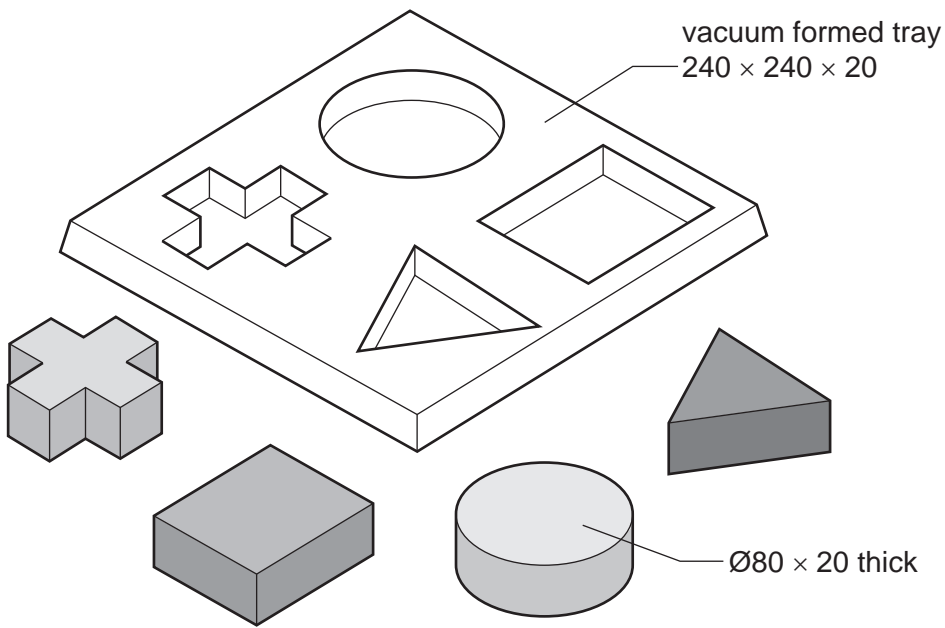

Fig. 9

(a) (i) Name a suitable plastic for the tray.

..... [1]

(ii) Give **two** benefits of using the vacuum forming process when making a large number of trays.

1

2 [2]

(b) Give **two** features of the design of the mould that would ensure a successfully vacuum formed tray.

1

2 [2]

(c) Use sketches and notes to show how the tray could be vacuum formed.

*For
Examiner's
Use*

[8]

(d) Give **two** ways in which the designer has made the toy suitable for use by children.

1

2 [2]

(e) Fig. 10 shows one round shape made from solid wood.

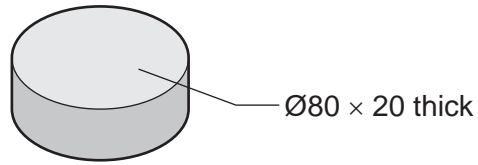

Fig. 10

Use sketches and notes to show how the round shape could be produced in a school workshop.

[8]

(f) Give **two** quality control checks that could be carried out when making the child's toy.

1

2 [2]

13 Fig. 11 shows views of a guitar stand made from mild steel.

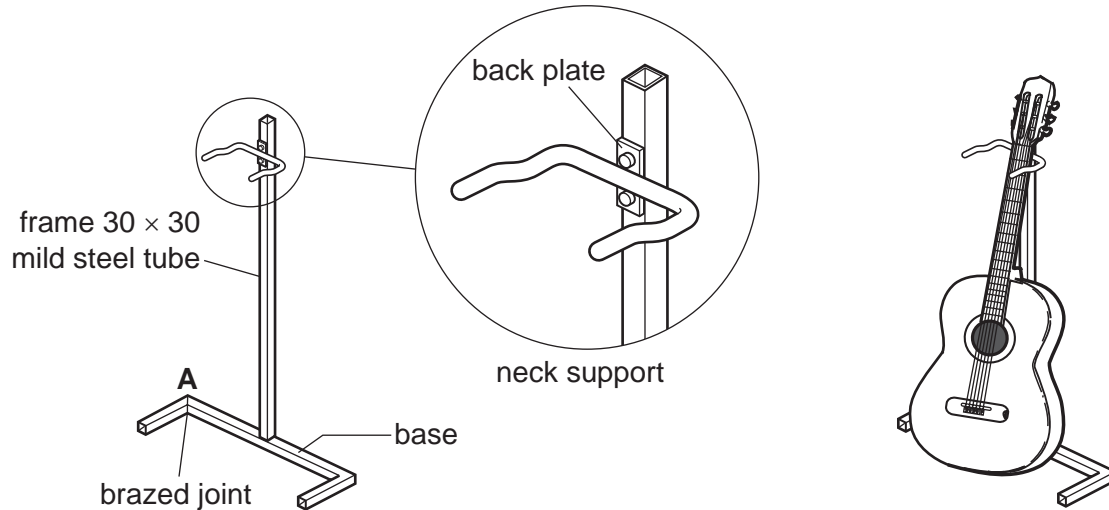

Fig. 11

(a) Give **two** properties of mild steel that make it suitable for the guitar stand.

- 1
- 2 [2]

(b) Fig. 12 shows part of the base of the guitar stand with corner **A** marked out.

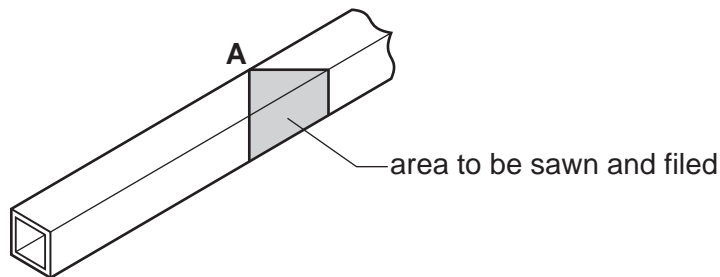

Fig. 12

Use sketches and notes to show how the mild steel tube could be sawn and filed ready to be brazed.

[4]

(c) Complete the table below by giving **five** additional stages needed to braze the joint at **A**.

	Stage
1	Saw and file the joints to fit
2	
3	
4	
5	
6	

[5]

(d) The support for the neck of the guitar is plastic coated.

(i) Give **one** reason why the support is plastic coated.

..... [1]

(ii) Use sketches and notes to show how the support could be plastic coated.

[5]

(e) Fig. 13 shows details of the back plate for the neck support.

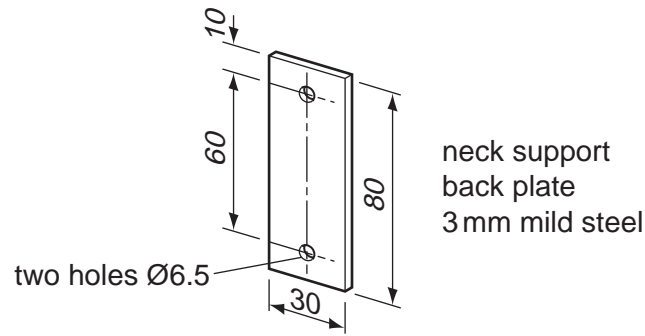

Fig. 13

Use sketches and notes to show a design for a jig that could be used when drilling the holes in the back plate.

The drilling jig must:

- secure the back plate when it is being drilled;
- position the two holes accurately.

[4]

(f) The neck support must be capable of being moved up or down to take different heights of guitar.

Use sketches and notes to show how the design of the guitar stand could be modified so that the neck support could be made to move up or down.

[4]

BLANK PAGE

Permission to reproduce items where third-party owned material protected by copyright is included has been sought and cleared where possible. Every reasonable effort has been made by the publisher (UCLES) to trace copyright holders, but if any items requiring clearance have unwittingly been included the publisher will be pleased to make amends at the earliest possible opportunity.

University of Cambridge International Examinations is part of the Cambridge Assessment Group. Cambridge Assessment is the brand name of University of Cambridge Local Examinations Syndicate (UCLES), which is itself a department of the University of Cambridge.