



UNIVERSITY OF CAMBRIDGE INTERNATIONAL EXAMINATIONS  
International General Certificate of Secondary Education

CANDIDATE  
NAME

CENTRE  
NUMBER

|  |  |  |  |  |
|--|--|--|--|--|
|  |  |  |  |  |
|--|--|--|--|--|

CANDIDATE  
NUMBER

|  |  |  |  |
|--|--|--|--|
|  |  |  |  |
|--|--|--|--|



**DESIGN AND TECHNOLOGY**

**0445/43**

Paper 4 Systems and Control

**May/June 2012**

**1 hour**

Candidates answer on the Question Paper.

No Additional Materials are required.

**To be taken together with Paper 1 in one session of 2 hours and 15 minutes.**

**READ THESE INSTRUCTIONS FIRST**

Write your Centre number, candidate number and name on all the work you hand in.

Write in dark blue or black pen.

You may use a soft pencil for any diagrams or graphs.

Do not use staples, paper clips, highlighters, glue or correction fluid.

**DO NOT WRITE IN ANY BARCODES.**

You may use a calculator.

**Section A**

Answer **all** questions.

**Section B**

Answer **one** question.

At the end of the examination, fasten all your work securely together.

The number of marks is given in brackets [ ] at the end of each question or part question.

| For Examiner's Use |  |
|--------------------|--|
| <b>Section A</b>   |  |
| <b>Section B</b>   |  |
| <b>Total</b>       |  |

This document consists of an **16** printed pages.



Section A

Answer **all** questions in this section.

- 1 Fig. 1a shows a garden shed. The door has structural weakness and needs to be modified to overcome this weakness.

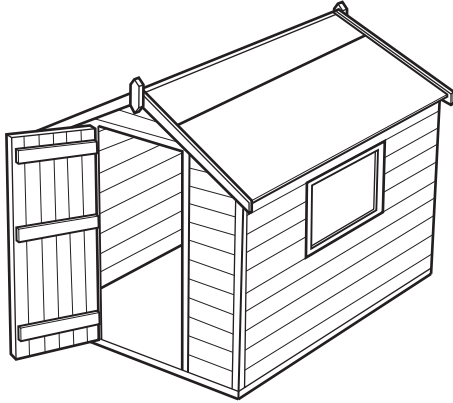

Fig. 1a

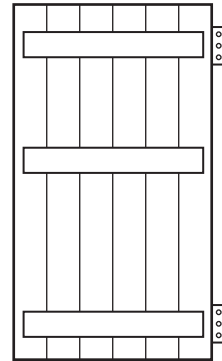

Fig. 1b

- (a) Explain what would happen to the shed door, over a period of time, if the modification was not carried out.

.....

.....

.....

..... [3]

- (b) Show on Fig. 1b how the door can be modified to ensure it has greater structural strength. [2]

- 2 Fig. 2 shows a method of jointing in a framework.

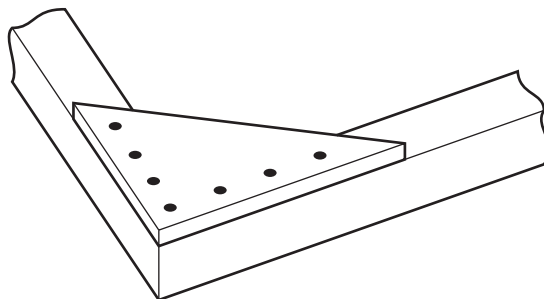

Fig. 2

Name the method shown.

..... [1]

3 Fig. 3 shows a graph of load against extension for a metal.

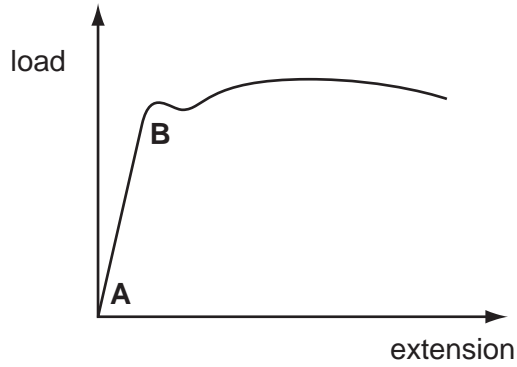

Fig. 3

Explain what is happening between the points A and B.

.....

.....

..... [2]

4 Fig. 4 shows a worm and wormwheel system.

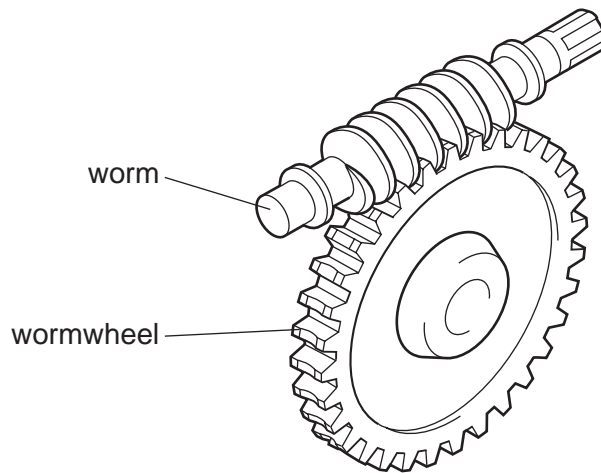

Fig. 4

(a) Label Fig. 4 to show the input gear and output gear.

..... [1]

(b) If the wormwheel has 32 teeth, state the gear ratio of the system.

..... [1]

5 Complete the table below showing mechanisms and their actions.

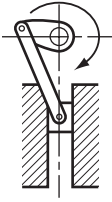
| mechanism        | sketch  | action             |
|------------------|---|--------------------|
| spur gears       |   | reduction of speed |
| crank and slider |  |                    |

[3]

6 Fig. 5 shows a diagram of a lever system.

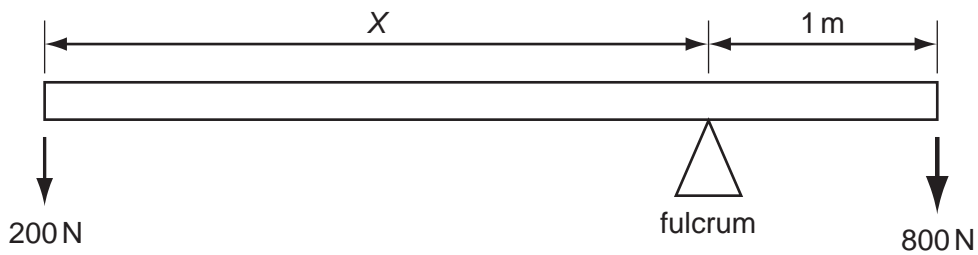

Fig. 5

Calculate the length of  $X$  for the lever when it is in equilibrium.

You must show all your working.

[3]

7 The table and diagram below show the colour code system for resistors.

| Colour | 1st band | 2nd band | 3rd band  | 4th band       |
|--------|----------|----------|-----------|----------------|
| Black  | 0        | 0        | -         | tolerance band |
| Brown  | 1        | 1        | 0         |                |
| Red    | 2        | 2        | 00        |                |
| Orange | 3        | 3        | 000       |                |
| Yellow | 4        | 4        | 0000      |                |
| Green  | 5        | 5        | 00000     |                |
| Blue   | 6        | 6        | 000000    |                |
| Violet | 7        | 7        | 0000000   |                |
| Grey   | 8        | 8        | 00000000  |                |
| White  | 9        | 9        | 000000000 |                |

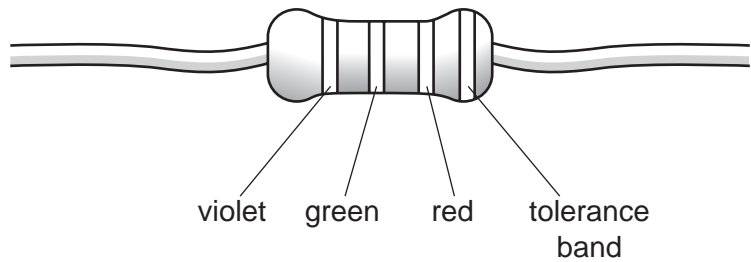

State the value of this resistor. You do not need to include the tolerance.

..... [3]

8 Complete the table showing switches and their uses.

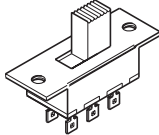
| switch      | sketch  | uses  |
|-------------|---|---|
| [1]         |  | reverse current flow to electric motors to change their direction of rotation |
| reed switch | [1]   | burglar alarm system  |

9 Explain why care is needed when connecting an electrolytic capacitor in a circuit.

.....  
.....  
..... [2]



10 Draw and label the circuit symbol for a NOR logic gate.

[2]

**Section B**

Answer **one** question from this section.

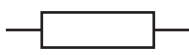
11 Fig. 6 shows an incomplete circuit for controlling a greenhouse plant watering system.

| component name | component symbol  |
|----------------|---|
| resistor       |  |
| diode          |  |
| relay          |  |

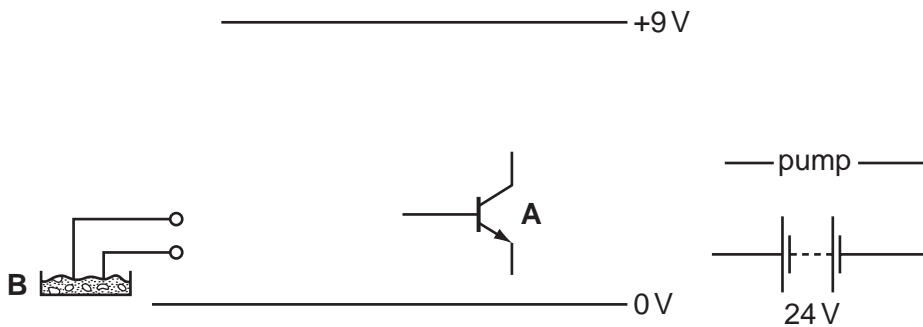

**Fig. 6**

- (a) (i) Using the components in the table, complete the circuit diagram for the control circuit. [6]
- (ii) State how component **A** would be fixed to a printed circuit board (PCB).  
 ..... [1]
- (iii) State the type of component that would be used at position **B** in the circuit.  
 ..... [2]
- (iv) Name and sketch a component that could be added to the circuit to increase its sensitivity.

[2]

**(b)** It is decided to add an on/off switch to the circuit. A single pole, single throw toggle switch is to be used.

**(i)** Draw the circuit symbol for this type of switch.

[2]

**(ii)** Name **one** other type of switch that would be suitable for this application.

..... [1]

**(iii)** Explain why a push to make (PTM) switch would not be suitable for this application.

.....  
..... [2]

**(c)** The circuit uses a resistor.

Explain how a resistor affects the voltage in a circuit.

.....  
.....  
..... [2]

**(d)** Briefly explain how a relay works.

.....  
.....  
.....  
.....  
..... [3]



(e) Fig. 7 shows a pair of resistors used to control voltage in a circuit.

For  
Examiner's  
Use

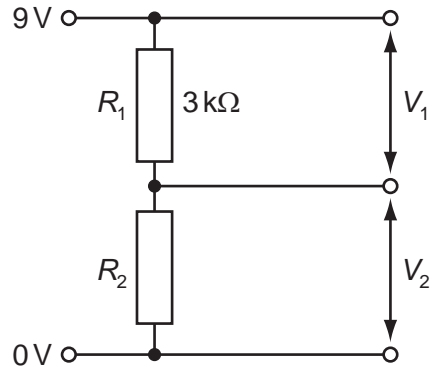

Fig. 7

(i) Name this arrangement of resistors.

..... [1]

(ii) Calculate the value of  $R_2$  if the current in the circuit is 1 mA.

Show all your workings.

[3]

12 Fig. 8 shows a device for launching a ball.

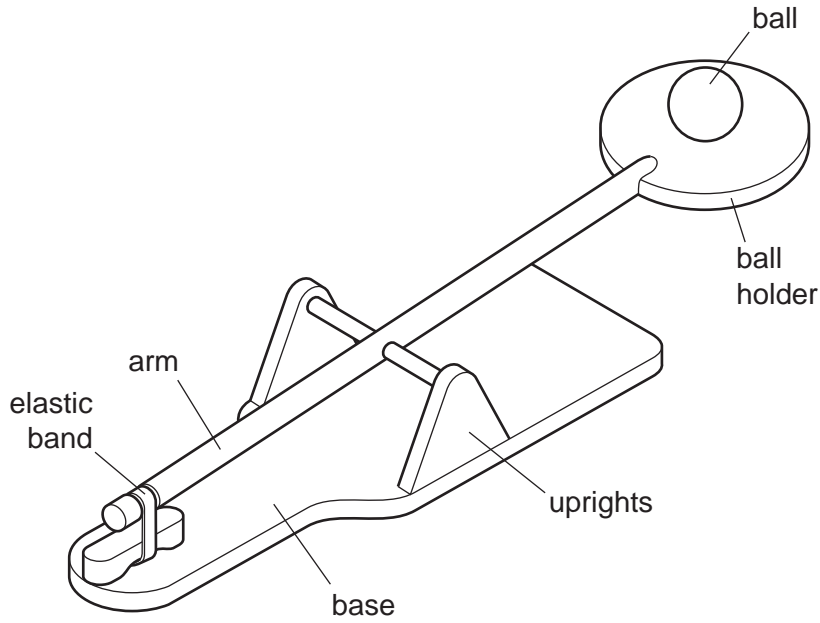

Fig. 8

(a) (i) Identify the class (order) of lever used in the ball-launching device.

..... [1]

(ii) On Fig. 8 label the load, effort and fulcrum for the lever when the ball is launched.

[3]

(iii) Explain how the device could be modified so that, when still using one elastic band, the ball could be launched higher.

.....  
 .....  
 ..... [2]

(b) Fig. 9 shows a diagram of a lever-operated can-crushing device.

For  
Examiner's  
Use

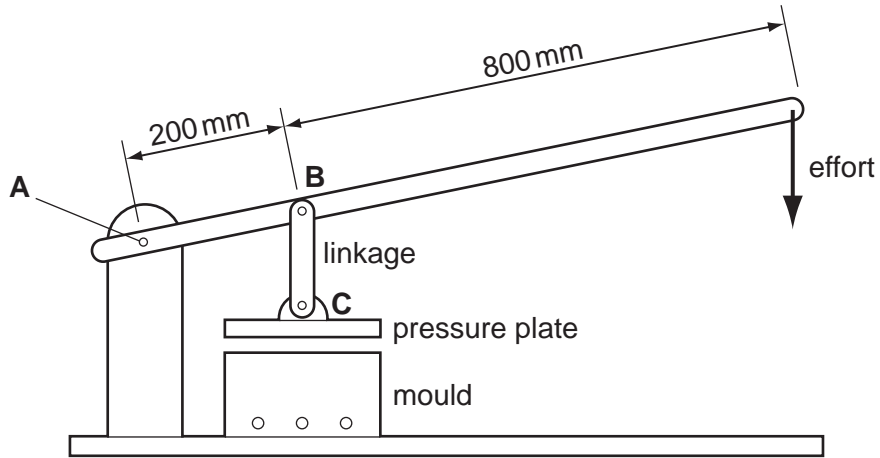

Fig. 9

- (i) Calculate the effort required to generate a force of 400 N at the pressure plate C. The pivot A is fixed.

Show all your workings.

[3]

- (ii) Complete the statement below.

The type of force acting on pin B is .....

[1]

(c) Fig. 10 shows a mechanism for motion conversion.

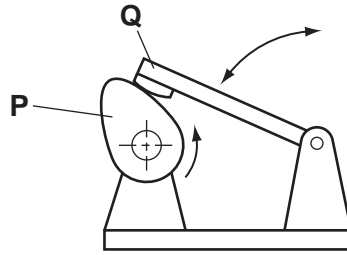

Fig. 10

(i) Name the **two** types of motion shown in Fig. 10.

..... [1]

..... [1]

(ii) Give the specific names of parts **P** and **Q**.

**P** ..... [2]

**Q** ..... [2]

(iii) Give **two** applications for the mechanism shown in Fig. 10.

.....

..... [2]

(d) Fig. 11 shows a rack and pinion mechanism.

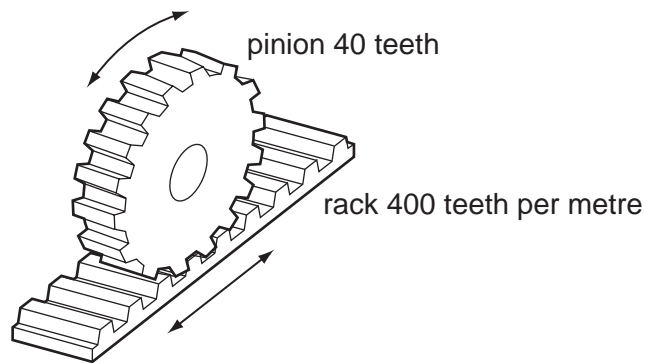

Fig. 11

(i) Give **one** example of the use of a rack and pinion system.

..... [1]

- (ii) For the rack and pinion system shown in Fig. 11, calculate the distance moved by the rack for one rotation of the pinion gear wheel.

Show all your working.

[3]

- (e) The use of bearings and lubrication is important in mechanical systems.

- (i) Explain how the use of bearings and lubrication reduces the amount of power needed to drive a mechanism.

.....  
.....  
..... [2]

- (ii) State **one** type of lubricant used in a motor vehicle transmission system.

..... [1]

13 Fig. 12 shows a shackle bolt.

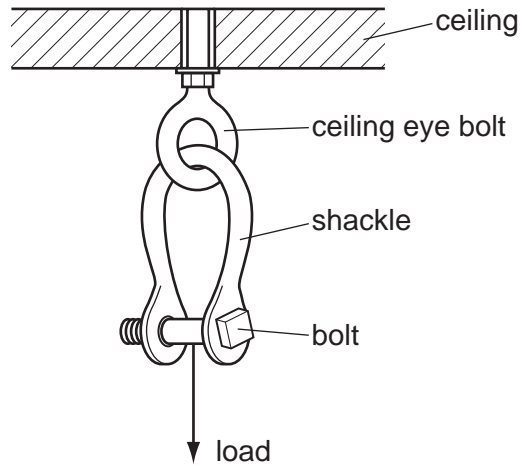

Fig. 12

(a) (i) State the forces acting in the shackle and the bolt when loaded as shown in Fig. 12.

Shackle ..... [1]

Bolt ..... [2]

(ii) State **one** property of mild steel that makes it suitable for this type of loading.  
..... [1]

(b) Explain how the design of the shackle helps to distribute stress when it is loaded.  
.....  
.....  
.....  
..... [3]

(c) The shackle uses a threaded bolt as a temporary fixing.  
(i) Explain why a threaded bolt is used in the shackle arrangement.  
.....  
.....  
..... [2]

(ii) Name **one** permanent fixing method used in structures and give a specific example of the use of this type of fixing method.

Name ..... [1]

Example ..... [1]

(d) Fig. 13 shows a framework for a temporary outdoor stage.

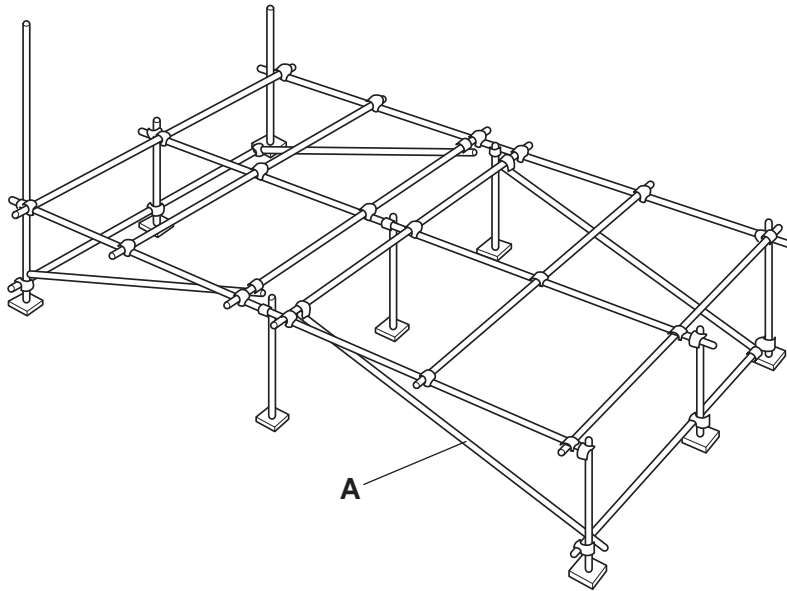

Fig. 13

Name and state the purpose of part A.

.....  
 ..... [2]

(e) Use notes and sketches to explain the term *redundant member*.

- (f) Fig. 14 shows a test sample used in an experiment to test a material's ability to withstand stress loading.

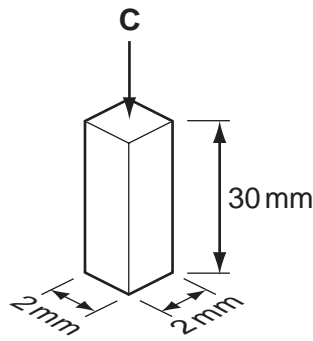

Fig. 14

- (i) Calculate the compressive force, **C**, that would produce a stress of  $250 \text{ N/mm}^2$  on this sample.

Show all your working.

[3]

- (ii) The sample also experiences strain. Explain what is meant by the term *strain*.

.....

.....

..... [3]

- (iii) The sample is compressed from 30 mm to 29.94 mm due to the compressive force. Calculate the strain on the sample. Show all your working.

[3]

Permission to reproduce items where third-party owned material protected by copyright is included has been sought and cleared where possible. Every reasonable effort has been made by the publisher (UCLES) to trace copyright holders, but if any items requiring clearance have unwittingly been included the publisher will be pleased to make amends at the earliest possible opportunity.

University of Cambridge International Examinations is part of the Cambridge Assessment Group. Cambridge Assessment is the brand name of University of Cambridge Local Examinations Syndicate (UCLES), which is itself a department of the University of Cambridge.