



UNIVERSITY OF CAMBRIDGE INTERNATIONAL EXAMINATIONS
International General Certificate of Secondary Education

CANDIDATE
NAME

CENTRE
NUMBER

--	--	--	--	--

CANDIDATE
NUMBER

--	--	--	--



DESIGN AND TECHNOLOGY

0445/42

Paper 4 Systems and Control

May/June 2011

1 hour

Candidates answer on the Question Paper.

No Additional Materials are required.

To be taken together with Paper 1 in one session of 2 hours and 15 minutes.

READ THESE INSTRUCTIONS FIRST

Write your Centre number, candidate number and name on all the work you hand in.

Write in dark blue or black pen.

You may use a soft pencil for any diagrams or graphs.

Do not use staples, paper clips, highlighters, glue or correction fluid.

DO NOT WRITE IN ANY BARCODES.

You may use a calculator.

Section A

Answer **all** questions.

Section B

Answer **one** question.

At the end of the examination, fasten all your work securely together.

The number of marks is given in brackets [] at the end of each question or part question.

For Examiner's Use	
Section A	
Section B	
Total	

This document consists of **15** printed pages and **1** blank page.



Section A

Answer **all** questions in this section.

For
Examiner's
Use

- 1 Complete the table below.

Force	Type of force	Example
Tension	[1]	Cable on a suspension bridge
Compression	Squashing or crushing	[1]
[1]	Twisting	[1]

- 2 Fig. 1 shows a design for a roof truss.

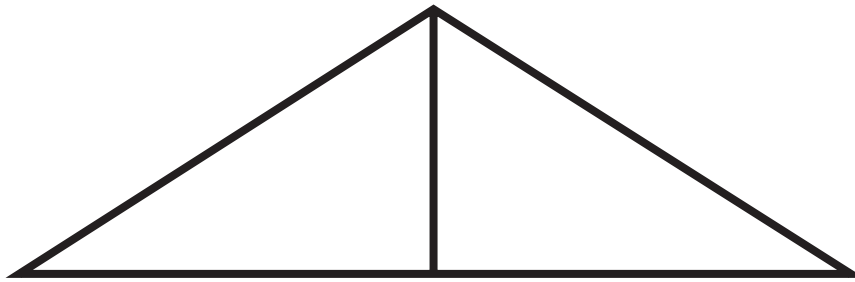

Fig. 1

Add sketches and labels to Fig. 1 to show how the truss could be reinforced using gusset plates to enable it to carry load more effectively. [3]

- 3 Some sheet material is naturally flexible and flimsy. Explain, using sketches and notes how sheet material can be made more rigid.

[3]

4 Electricity can be supplied from a variety of sources. Complete the table below.

Source	Energy conversion	Example of use
Dry cell battery	[1]	[1]
Solar cell	Light into electrical	[1]
Dynamo	[1]	Bicycle lamp

5 Fig. 2 shows a circuit symbol.

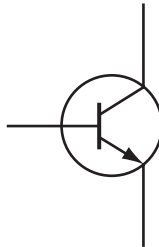

Fig. 2

Identify the component shown in Fig. 2

..... [1]

6 A reed switch is used in a burglar alarm system. Describe how the switch works.

.....

 [2]

7 Give **one** example of a product that uses logic systems to control its operation.

..... [1]

8 Complete the table below.

Type of motion	Description	Example of use
Linear	Moving in a straight line	[1]
Rotary	[1]	Drilling machine
[1]	Moving back and forth in a straight line	Jig saw blade
Oscillating	Swinging back and forth in an arc	[1]

9 Fig. 3 shows a schematic diagram of a lever.

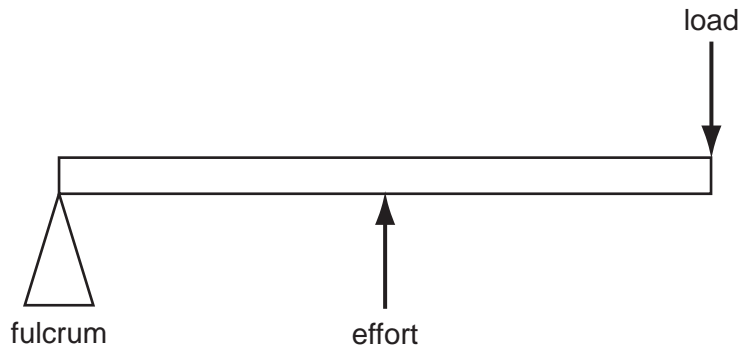

Fig. 3

(a) Identify the order (class) of lever shown.

..... [1]

(b) Give **one** example of the use of this order (class) of lever.

..... [1]

10 Give **one** example of the use of a toothed pulley system.

..... [1]

Section B

Answer **one** question from this section.

For
Examiner's
Use

11 (a) Fig. 4 shows a diagram of a ratchet and pawl mechanism.

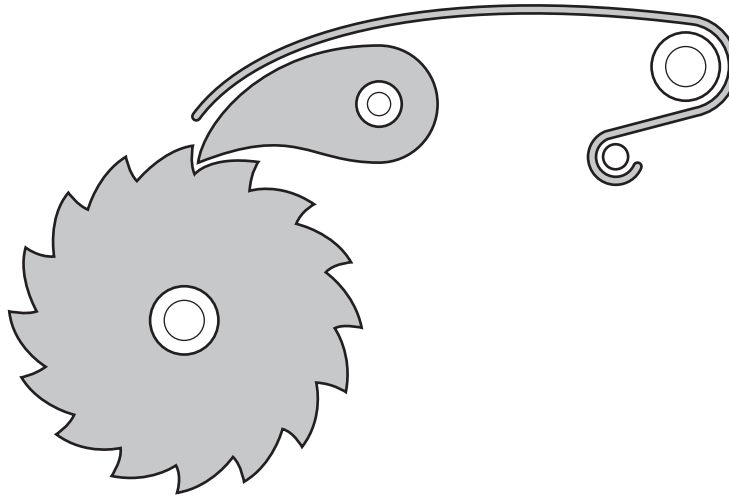

Fig. 4

(i) Add labels to Fig. 4 to show the following:

Ratchet; pawl; spring; direction of free rotation. [4]

(ii) Give **one** example of the use of a ratchet and pawl mechanism.

..... [1]

(iii) Suggest **one** way that the locking action of the ratchet and pawl could be released when necessary.

.....
.....
..... [2]

(b) Describe the motion conversion that takes place when a screw thread is operated.

.....
..... [2]

- (c) Sprocket and chain mechanisms are used to transmit motion. Describe **one** advantage that sprocket and chain mechanisms have over belt and pulley systems.

.....
 [2]

- (d) Fig. 5 shows a schematic drawing of a sprocket and chain system.

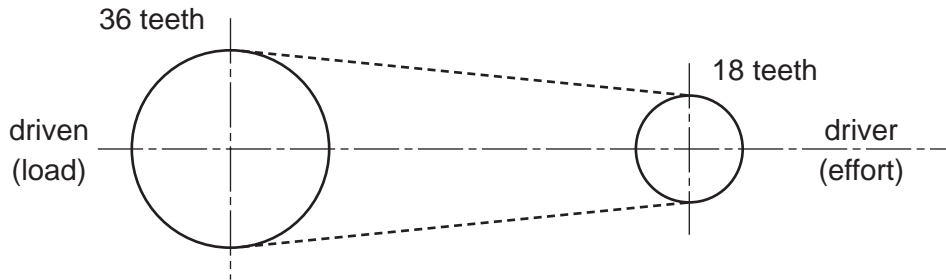

Fig. 5

- (i) Calculate the velocity ratio of the system.

[3]

- (ii) If the driver speed is 200 rpm, calculate the speed of the driven sprocket.

[2]

- (iii) Calculate the mechanical advantage of the system, if the efficiency of the system is 60%.

[3]

(e) The efficiency of a mechanical system is determined by a number of factors.

- (i) Bearings may be used to reduce friction.
Use sketches and notes to describe a plain bearing.

[3]

(ii) Give **one** example of the use of a ball bearing.

..... [1]

(iii) Apart from the use of bearings explain how friction between two surfaces can be reduced.

.....
.....
..... [2]

12 Transducers are used in the sensing of changes in the environment and to trigger the operation of electronic systems.

(a) Complete the table below.

Transducer	Environmental change sensed	Example of use
LDR	[1]	[1]
[1]	Temperature	Frost alarm
Strain gauge	Length of a structural member	[1]

(b) (i) Sketch and label an LDR component.

[3]

(ii) Sketch the circuit symbol for an LDR.

[2]

(c) LEDs can be used as output devices to provide a light signal.

(i) Sketch and label an LED component to show the positive and negative connections and how these connections are identifiable.

[3]

(ii) An LED must be connected in series with a resistor. Explain why this is necessary.

.....
.....
..... [2]

(iii) Give **one** specific example of the use of an LED.

..... [1]

(d) Fig. 6 shows an LED connected in series with a resistor.

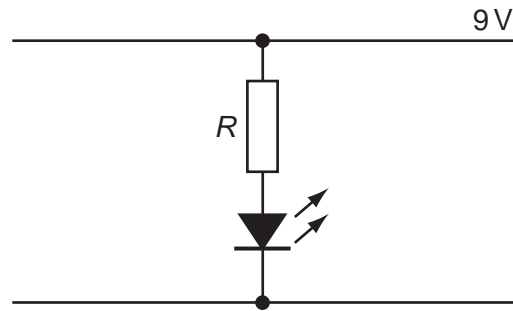

Fig. 6

(i) If the current flowing through the LED is 20 mA, calculate the value of R .

[3]

(ii) Use the table below to determine the colour coding for the nearest preferred value for this resistor.

Colour	1st band	2nd band	3rd band	4th band
Black	0	0	-	tolerance band
Brown	1	1	0	
Red	2	2	00	
Orange	3	3	000	
Yellow	4	4	0000	
Green	5	5	00000	
Blue	6	6	000000	
Violet	7	7	0000000	
Grey	8	8	00000000	
White	9	9	000000000	

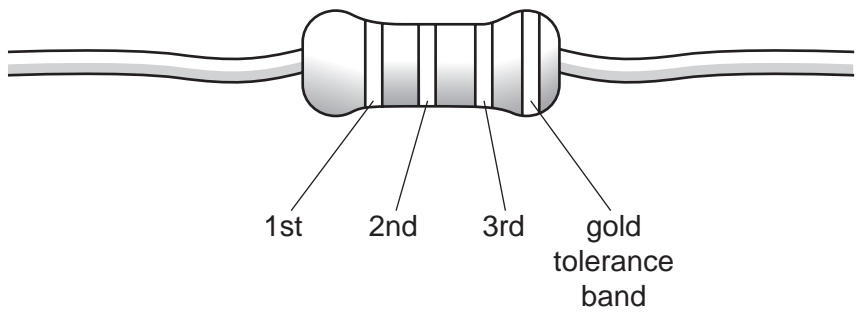

1st: [1]

2nd: [1]

3rd: [1]

(e) Below is a truth table for a logic gate.

Input A	Input B	Output
0	0	0
0	1	0
1	0	0
1	1	1

(i) Identify the logic gate represented by the truth table.

..... [1]

(ii) Sketch the circuit symbol for this logic gate clearly showing the input and the output connections.

[3]

13 Fig. 7 shows a diagram of a building.

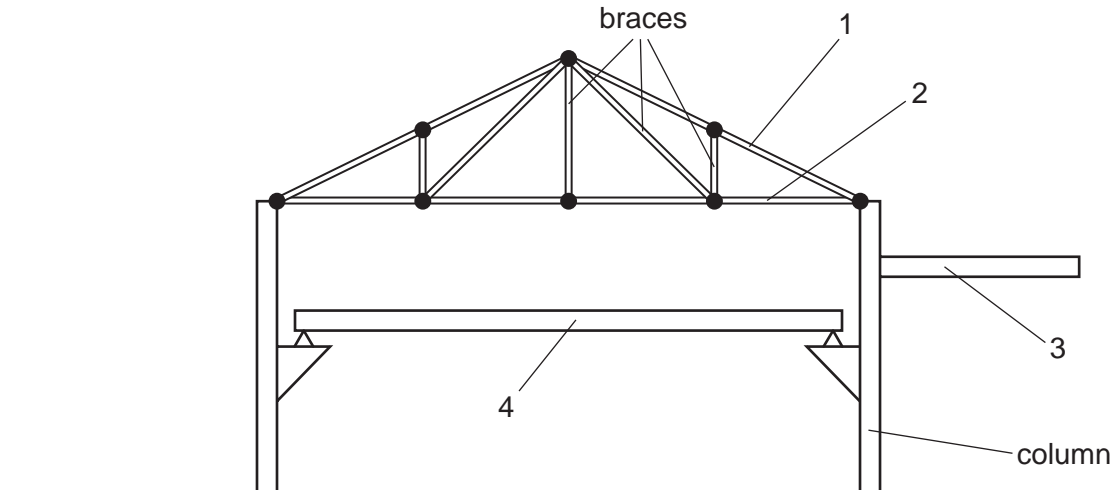

Fig. 7

(a) Complete the table below.

Member	Name
1	
2	
3	
4	

[4]

(b) Explain the need for the braces in the roof truss.

.....

 [2]

(c) (i) Give **two** reasons why square section tubular mild steel has been selected for the column.

1 [1]
 2 [1]

(ii) Use sketches and notes to show the forces acting on member 4.

[3]

(d) Structures under load will deflect. Use sketches and notes to explain how a simple dial gauge can be used to measure deflection.

[3]

(e) Use sketches and notes to explain how a strain gauge works.

[3]

(f) Structural members may be joined using a variety of methods.

(i) Complete the table below.

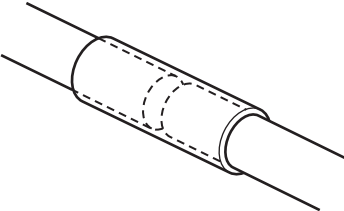
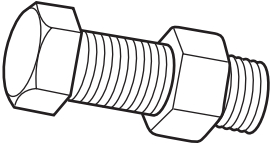
Joining method	Diagram	Use
Welding	[2]	[1]
[1]		Joining tent poles
Nuts and bolts		[1]

(ii) Explain why it is important to use washers when using nuts and bolts.

.....

.....

.....

..... [3]

Permission to reproduce items where third-party owned material protected by copyright is included has been sought and cleared where possible. Every reasonable effort has been made by the publisher (UCLES) to trace copyright holders, but if any items requiring clearance have unwittingly been included the publisher will be pleased to make amends at the earliest possible opportunity.

University of Cambridge International Examinations is part of the Cambridge Assessment Group. Cambridge Assessment is the brand name of University of Cambridge Local Examinations Syndicate (UCLES), which is itself a department of the University of Cambridge.