



UNIVERSITY OF CAMBRIDGE INTERNATIONAL EXAMINATIONS
International General Certificate of Secondary Education

CANDIDATE
NAME

CENTRE
NUMBER

--	--	--	--	--

CANDIDATE
NUMBER

--	--	--	--



DESIGN AND TECHNOLOGY

0445/43

Paper 4 Systems and Control

October/November 2010

1 hour

Candidates answer on the Question Paper.

No Additional Materials are required.

To be taken together with Paper 1 in one session of 2 hours and 15 minutes.

READ THESE INSTRUCTIONS FIRST

Write your Centre number, candidate number and name on all the work you hand in.

Write in dark blue or black pen.

You may use a soft pencil for any diagrams or graphs.

Do not use staples, paper clips, highlighters, glue or correction fluid.

DO NOT WRITE IN ANY BARCODES.

You may use a calculator.

Section A

Answer **all** questions.

Section B

Answer **one** question.

At the end of the examination, fasten all your work securely together.

The number of marks is given in brackets [] at the end of each question or part question.

For Examiner's Use	
Section A	
Section B	
Total	

This document consists of an **14** printed pages and **2** blank pages.



Section A

*For
Examiner's
Use*

Answer **all** questions in this section.

1 Name **four** types of motion.

..... [1]
..... [1]
..... [1]
..... [1]

2 Sketch and label a lever and clearly show the:

- load;
- effort;
- fulcrum.

[4]

3 Give **one** example of a device that uses a screw mechanism.

..... [1]

4 Explain the difference between static and dynamic forces.

.....
.....
.....
..... [3]

5 Give **one** example of a compressive force acting on a structure.

..... [1]

6 Fig. 1 shows a beam bending under load.

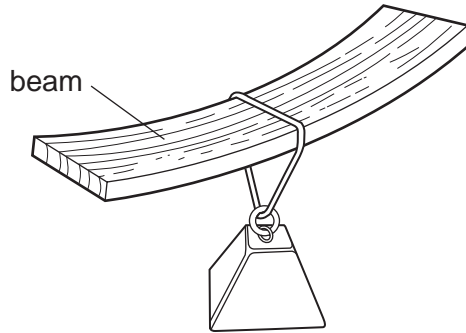

Fig. 1

Use notes and sketches to show how the beam could be made to support the same load with less bending.

[2]

7 Name **one** method of reinforcing a structure and give an example of its use.

Name

Example

8 Output devices that give off light include bulbs and LEDs.
Give **two** benefits of using LEDs.

- 1
- 2 [2]

9 Fig. 2 shows a timer circuit.

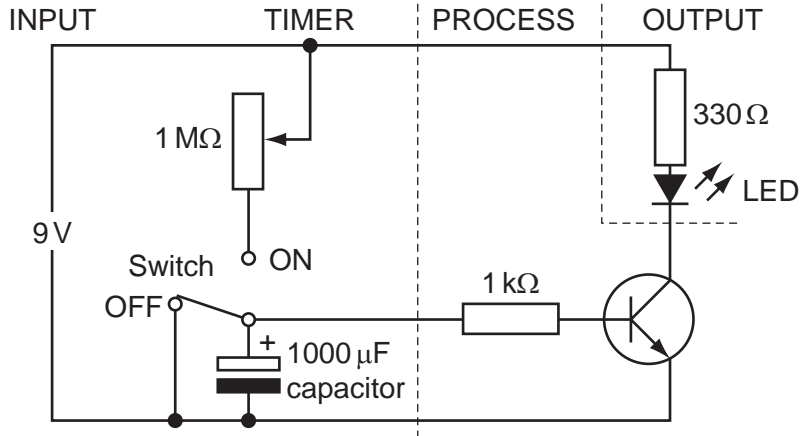

Fig. 2

(a) Explain how this circuit works.

-
-
-
- [3]

(b) Explain the purpose of the variable resistor.

-
-
- [2]

(c) Name the type of capacitor shown in Fig. 2.

- [1]

Section B

Answer **one** question from this section.

For
Examiner's
Use

10 Fig. 3 shows a circuit plan for a timer.

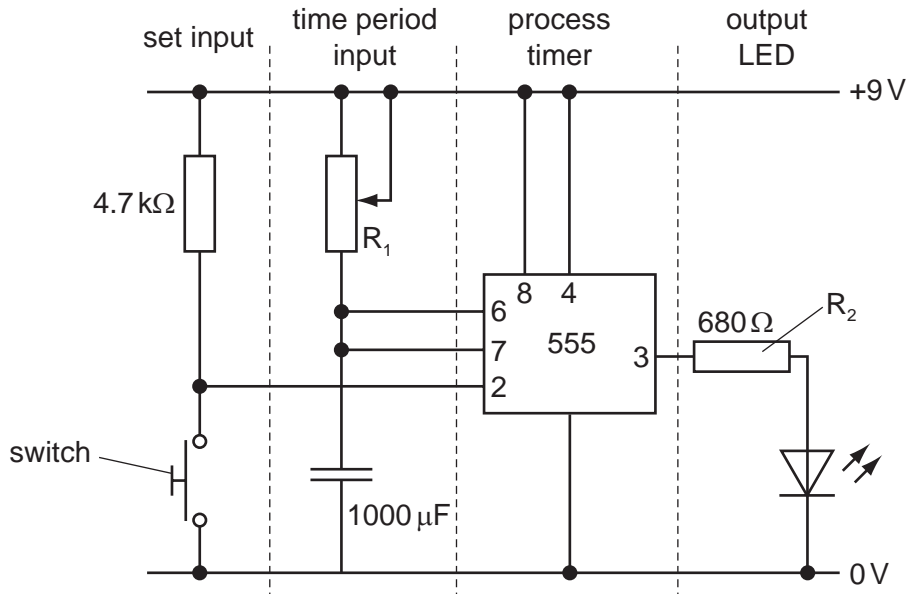

Fig. 3

(a) If the value of R_1 is $1\text{ k}\Omega$, calculate the time period.

[3]

(b) (i) Identify the switch shown in Fig. 3.

..... [1]

(ii) Explain why this switch has been selected.

.....
..... [2]

(c) Explain the purpose of R_2 .

.....
..... [2]

(d) A battery is used as a power supply for this circuit.

(i) Sketch and label the circuit symbol for a 9 V battery.

[3]

(ii) Give **three** reasons why a battery would be used to power the circuit.

1
2
3 [3]

(iii) Use sketches and notes to show the energy conversions that take place when the LED is illuminated.

[3]

- (e) Sketch and label a graph showing the charging of a capacitor.

*For
Examiner's
Use*

[4]

- (f) Sketch and label a 3D drawing of an LED. Clearly show how the positive and negative connections are indicated.

[4]

11 Fig. 4 shows two linkages.

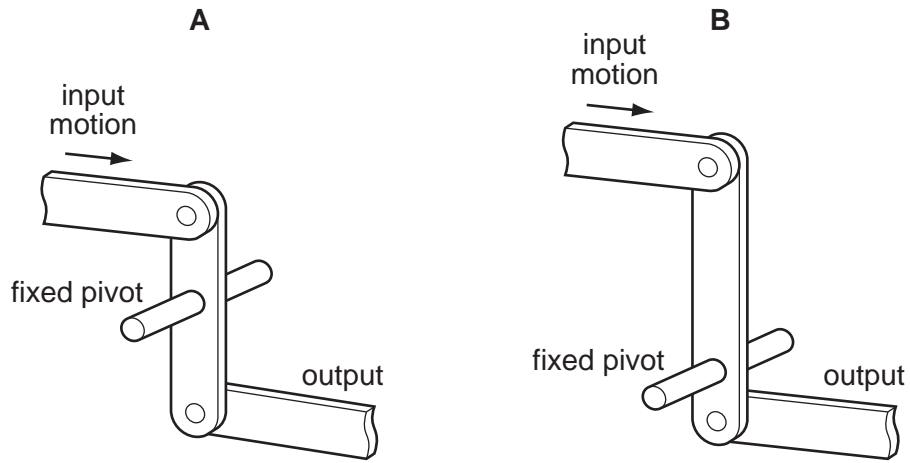

Fig. 4

(a) (i) Describe the output in terms of force and direction for linkage A.

.....
 [2]

(ii) Describe the output in terms of force and direction for linkage B.

.....
 [2]

(b) Fig. 5 shows a bell crank lever.

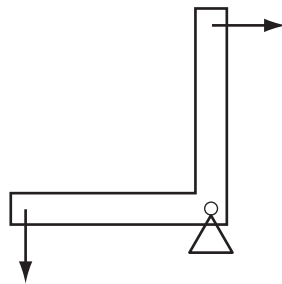

Fig. 5

(i) Explain the purpose of this type of lever.

.....

 [3]

(ii) Give **one** example of the use of a bell crank lever.

..... [1]

(c) Fig. 6 shows a weighing device.

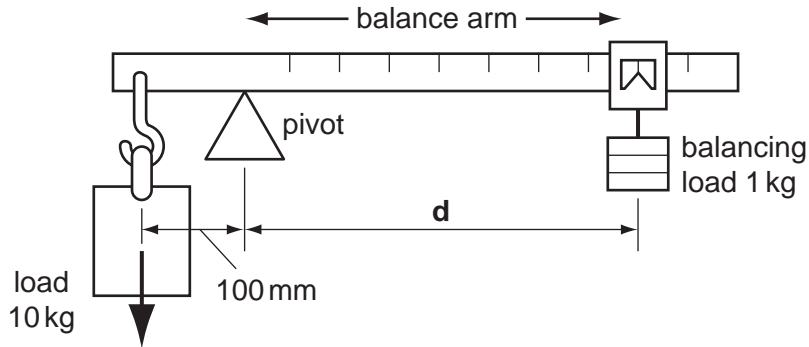

Fig. 6

Calculate the distance, d , that the balancing load must be from the pivot, to achieve equilibrium.

[3]

(d) The weighing device experiences moments of force.
Explain what is meant by a 'moment of force'.

.....

 [3]

(e) Fig. 7 shows a pantograph linkage used to produce enlarged copies of drawings.

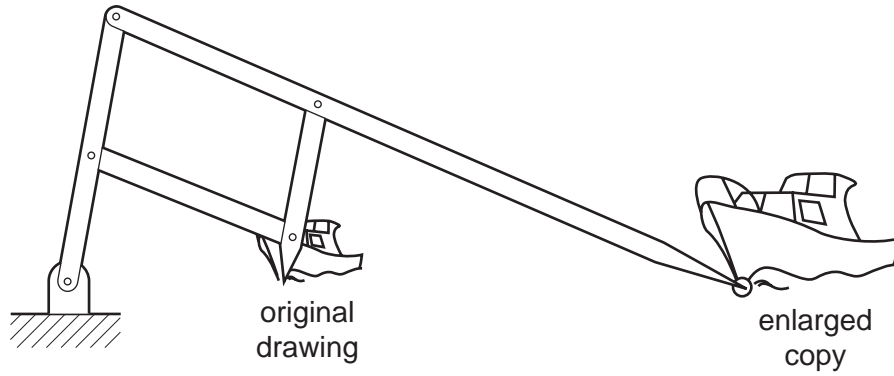

Fig. 7

Explain how the pantograph uses the principle of levers to enlarge the copy.

.....

.....

.....

..... [3]

(f) Fig. 8 shows a toggle clamp linkage.

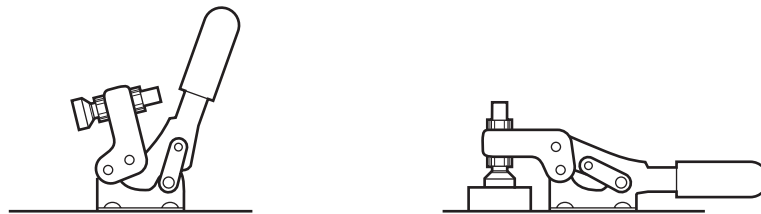

Fig. 8

(i) Give **one** example of the use of a toggle clamp.

..... [1]

(ii) Use notes and sketches to explain how the toggle clamp works.

[3]

(g) Fig. 9 shows a floor mop linkage.

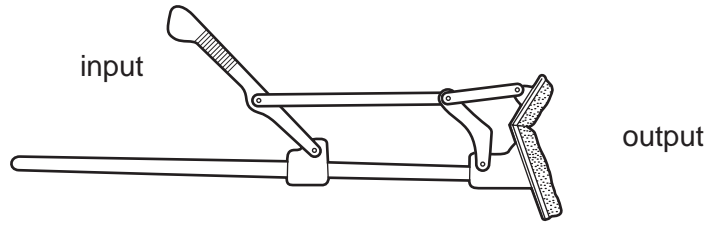

Fig. 9

(i) Add arrows to Fig. 9 to show the movement of the input and the output. [2]

(ii) Add labels to Fig. 9 to show **one** fixed pivot and **one** moving pivot. [2]

12 Fig. 10 shows a variety of structural components.

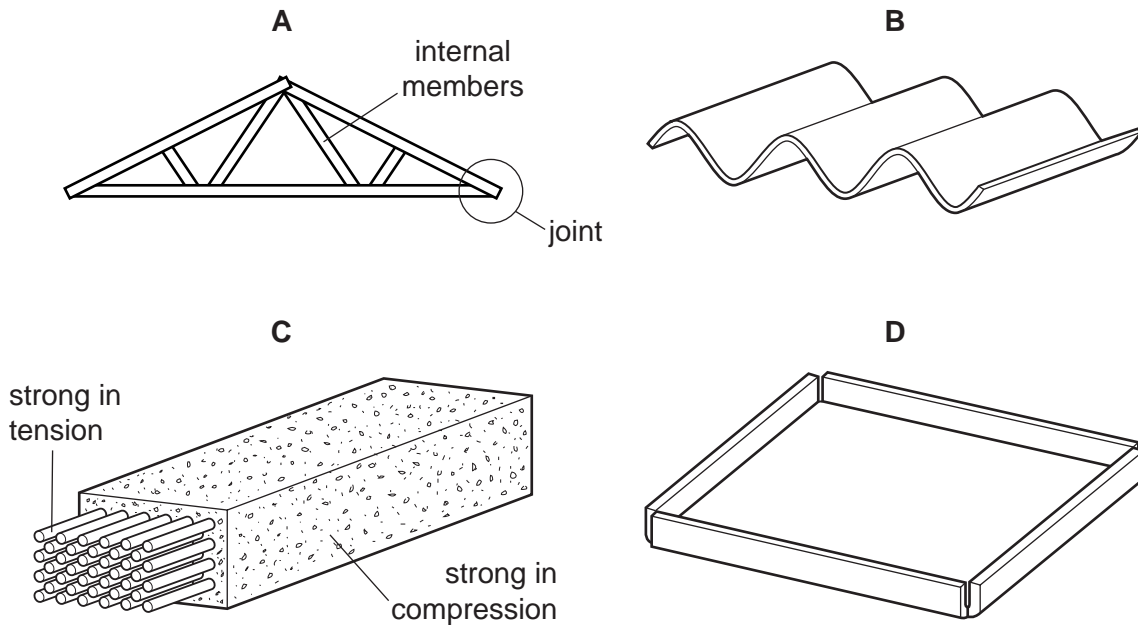

Fig. 10

(a) (i) Identify structure A.

..... [1]

(ii) Explain the purpose of the internal members of structure A.

.....

 [2]

(iii) Use sketches and notes to show how the joint shown in structure **A** can be reinforced.

[3]

(b) Explain why the corrugated sheet, **B**, is structurally better than a flat sheet.

.....
.....
.....
..... [2]

(c) (i) Identify component **C**.

..... [1]

(ii) Give **one** example of its use.

..... [1]

(d) Structure **D** is to be made from 1.5 mm mild steel sheet.

(i) Name **one** permanent method for joining the corners.

..... [1]

(ii) Name **one** temporary method for joining the corners.

..... [1]

(e) Fig. 11 shows a diagram of a simply supported beam.

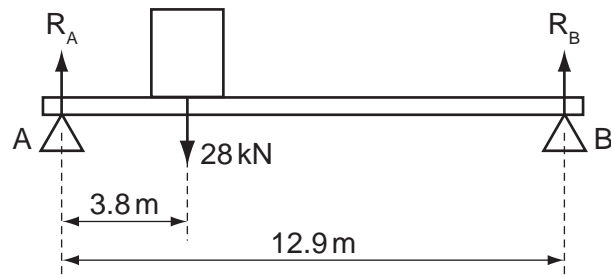

Fig. 11

Calculate the values of the reactions R_A and R_B .

[4]

(f) Fig. 12 shows a variety of different sections for beams.

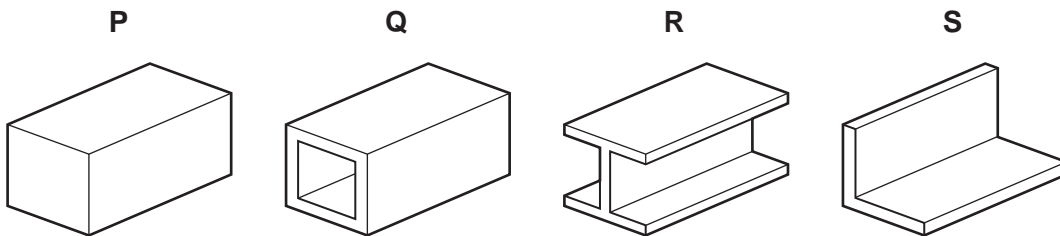

Fig. 12

(i) Explain why sections Q, R and S are preferred to section P.

.....

[2]

(ii) Give one example of use for beam Q.

.....

[1]

(iii) Explain why, in structural terms, beam R is shaped in this way.

.....

.....

.....

..... [3]

(g) The beams shown in Fig. 12 are to be made from mild steel.

Complete Fig. 13 to show a typical stress/strain graph for mild steel, labelling the:

- elastic region;
- plastic region;
- break point.

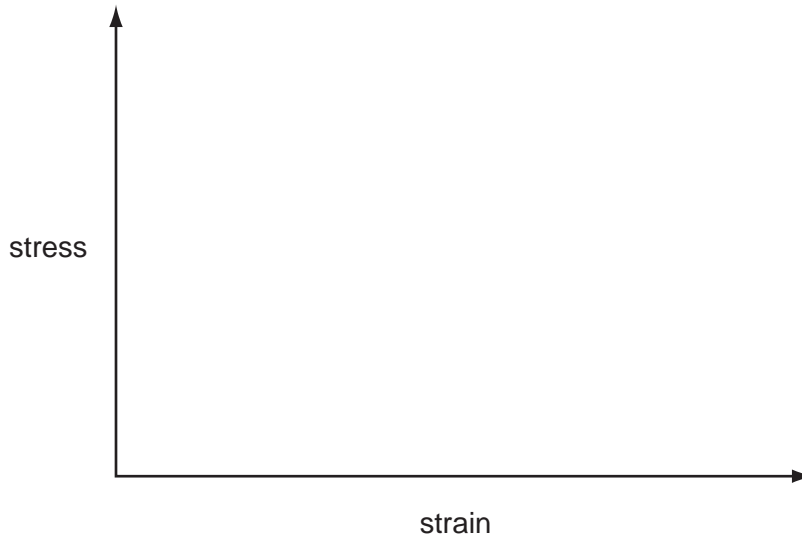

Fig. 13

[3]

Permission to reproduce items where third-party owned material protected by copyright is included has been sought and cleared where possible. Every reasonable effort has been made by the publisher (UCLES) to trace copyright holders, but if any items requiring clearance have unwittingly been included the publisher will be pleased to make amends at the earliest possible opportunity.

University of Cambridge International Examinations is part of the Cambridge Assessment Group. Cambridge Assessment is the brand name of University of Cambridge Local Examinations Syndicate (UCLES), which is itself a department of the University of Cambridge.