



UNIVERSITY OF CAMBRIDGE INTERNATIONAL EXAMINATIONS
International General Certificate of Secondary Education

CANDIDATE
NAME

CENTRE
NUMBER

--	--	--	--	--

CANDIDATE
NUMBER

--	--	--	--



DESIGN AND TECHNOLOGY

0445/31

Paper 3 Resistant Materials

October/November 2010

1 hour

Candidates answer on the Question Paper.

No Additional Materials are required.

To be taken together with Paper 1 in one session of 2 hours 15 minutes.

READ THESE INSTRUCTIONS FIRST

Write your Centre number, candidate number and name on all the work you hand in.

Write in blue or black pen.

You may use a soft pencil for any diagrams, graphs or rough working.

Do not use staples, paper clips, highlighters, glue or correction fluid.

DO **NOT** WRITE IN ANY BARCODES.

Section A

Answer **all** questions in this section.

Section B

Answer **one** question in this section.

You may use a calculator.

The total of the marks for this paper is 50.

The number of marks is given in brackets [] at the end of each question or part question.

For Examiner's Use	
Section A	
Section B	
Total	

This document consists of **15** printed pages and **1** blank page.



Section A

Answer **all** questions in this section.

1 (a) Name the type of plane shown in Fig. 1.

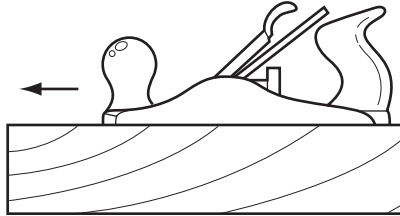

Fig. 1

..... [1]

(b) Give **two** reasons why the wood in Fig. 1 should **not** be planed in the direction shown.

1 [1]

2 [1]

2 Fig. 2 shows a marking gauge.

(a) Draw a steel rule against the marking gauge to show how the marking gauge would be set to the required distance.

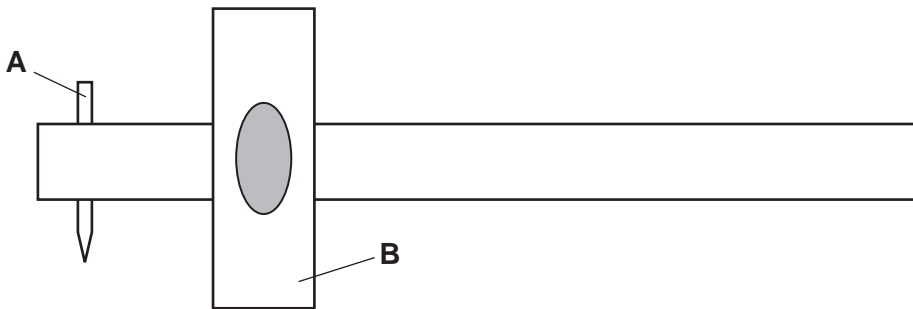

Fig. 2

[2]

(b) Name the parts of the marking gauge labelled **A** and **B**.

A [1]

B [1]

3 (a) Name the type of hammer shown below.

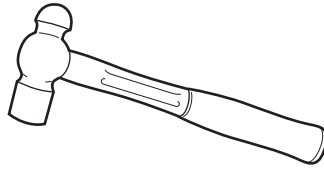

..... [1]

(b) Suggest **one** use for the hammer shown in (a).

..... [1]

4 Add sketches and notes to Fig. 3 to show how the corner butt joint could be strengthened.

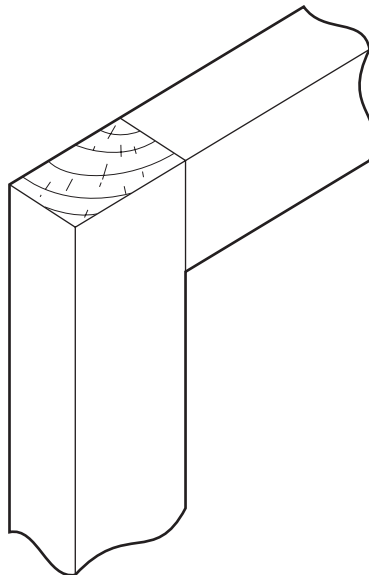

Fig. 3

[2]

5 Fig. 4 shows the end of a length of wood. Complete Fig. 4 to show a chamfered edge and a bevelled edge.

chamfered edge

bevelled edge

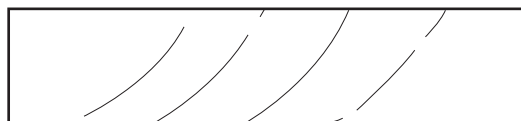

Fig. 4

[2]

6 Fig. 5 shows a variety of gear wheels made from a plastic.

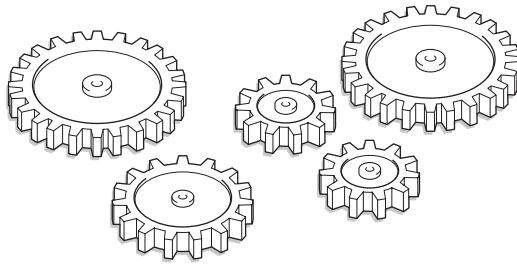

Fig. 5

(a) Name a specific plastic for the gear wheels.

..... [1]

(b) Describe a property of your chosen plastic that makes it suitable for gear wheels.

..... [1]

(c) Name the manufacturing process by which the gear wheels would be produced.

..... [1]

7 Fig. 6 shows a table lamp made from metal.

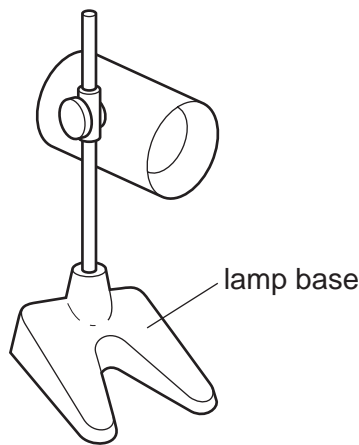

Fig. 6

(a) Name the process used to make the lamp base.

..... [1]

(b) Name a suitable metal for the base.

..... [1]

8 Give **two** reasons why scrapwood is used when cutting the lap joint shown below.

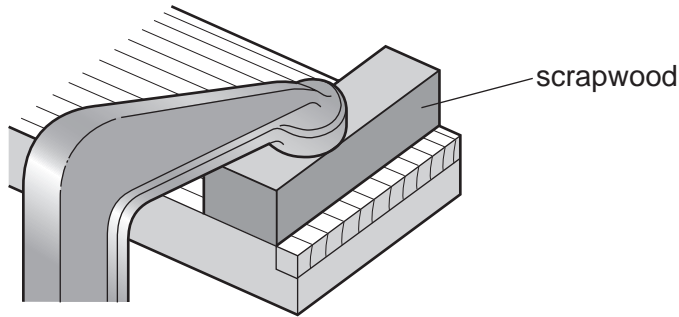

1 [1]

2 [1]

9 Name the marking out equipment shown below.

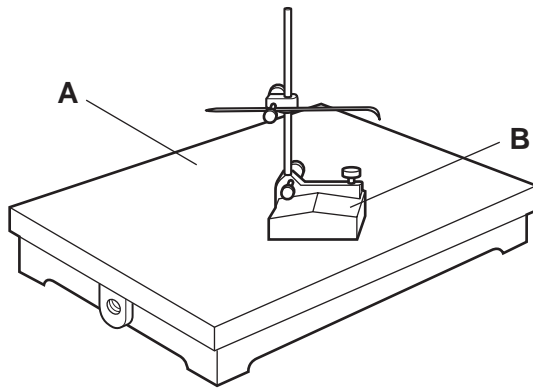

A [1]

B [1]

10 Complete the sketch below to show a corner halving joint.

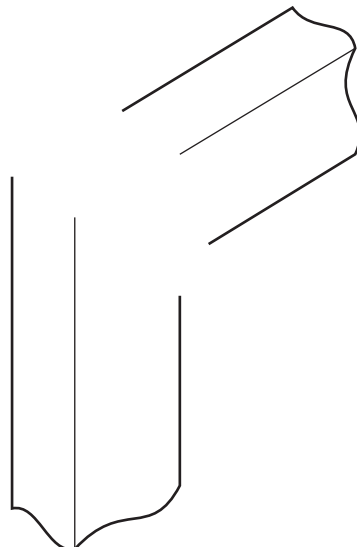

[3]

Section B

Answer **one** question from this section.

11 Fig. 7 shows a camping stool made from solid wood.

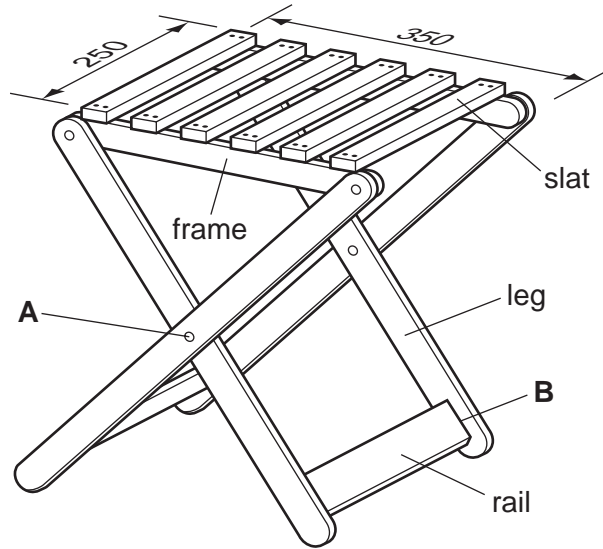

Fig. 7

(a) Suggest a suitable width and thickness for the slats.

Width [1]

Thickness [1]

(b) (i) Complete the drawing below to show how a countersunk head screw could be used to join a slat to the frame.

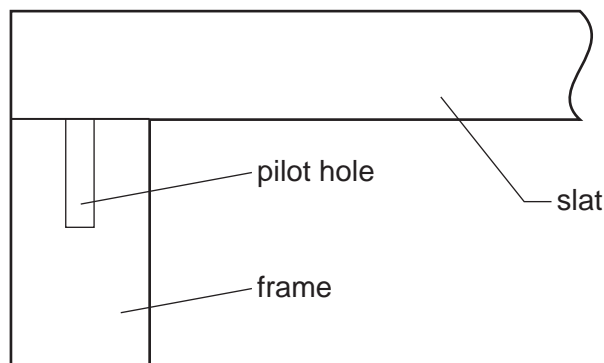

[2]

(ii) Give **two** advantages of using screws rather than nails for joining the slats to the frame.

1 [1]

2 [1]

(iii) Give **one** advantage of using brass screws rather than steel screws for joining the slats to the frame.

..... [1]

(c) The slats will be cut from a length of solid wood.
Use sketches and notes to show how you would measure, mark out and saw **one** slat to length.

[5]

(d) Use sketches and notes to show how the legs are joined at **A**.

[3]

[Turn over

(e) (i) Name and sketch a suitable construction that could be used to join a rail and leg at B.

Name [1]

Sketch

[3]

(ii) Use sketches and notes to show how the legs and rail would be clamped when glueing.

[3]

(f) (i) Name a suitable finish for the camping stool.

..... [1]

(ii) Give **two** reasons for your choice.

1 [1]

2 [1]

12 Fig. 8 shows a spice rack made from acrylic.

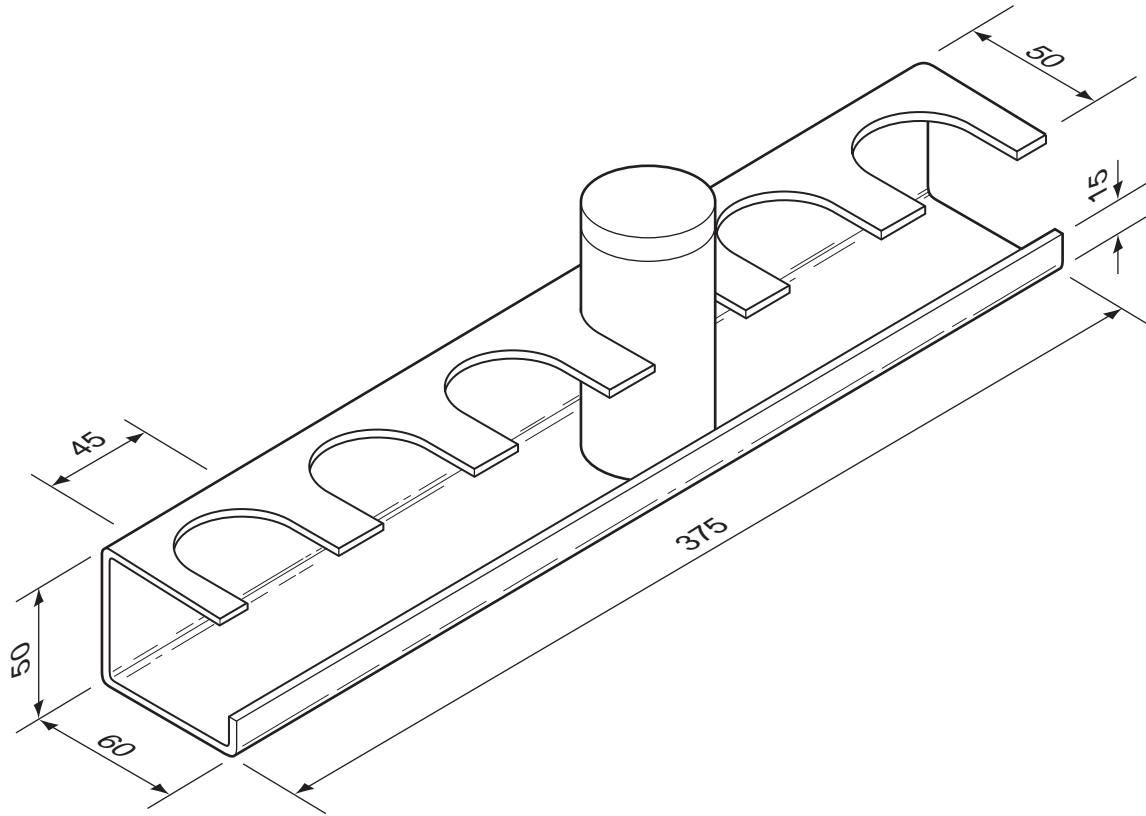

Fig. 8

(a) Complete the development (net) below to show the bend lines for the spice rack.



[3]

(b) Give **two** reasons why it would be useful to make a model of the spice rack before making it in acrylic.

1 [1]

2 [1]

(c) Use sketches and notes to show how **one** slot could be produced in the acrylic.

[6]

(d) (i) State why acrylic sheet is covered with paper or plastic when purchased.

..... [1]

(ii) Give **one** reason why acrylic does **not** need an applied finish.

..... [1]

(iii) Describe how the edges of acrylic would be finished.

.....
.....
.....
..... [3]

(e) Holes will be drilled in the spice rack so that it can be fixed to a wall. There is a danger that the acrylic could be damaged when drilling the holes.

State **three** precautions you would take to prevent this damage.

1 [1]

2 [1]

3 [1]

(f) Use sketches and notes to show how the spice rack could be produced from a single piece of acrylic **after** the slots have been cut out.

[6]

- 13 Fig. 9 shows a novelty CD rack based on the shape of a hedgehog. The rack is supplied as flat pack for self-assembly.

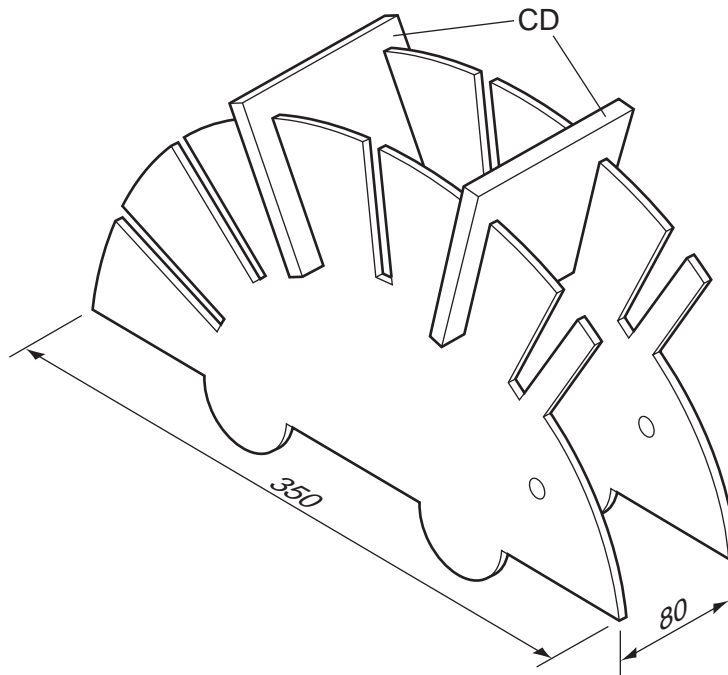

Fig. 9

The CD rack could be made from **either** sheet metal **or** manufactured board.

- (a) (i) Name a suitable, specific sheet metal **or** manufactured board for the CD rack.

..... [1]

- (ii) Give a reason for your choice.

..... [1]

- (iii) Suggest a suitable thickness for your chosen sheet material.

..... [1]

- (b) State **two** items of research a designer would need to find out before designing the CD rack.

1 [1]

2 [1]

- (c) Give **two** reasons why it would be useful to use a template when making a batch of 10 CD racks.

1 [1]

2 [1]

(d) (i) Use sketches and notes to show how you would mark out, cut and shape **one** side of the CD rack. Name the tools and/or equipment used.

[6]

(ii) Describe **two** safety precautions you would need to take when carrying out any process in (d)(i).

1 [1]

2 [1]

- (e) Use sketches and notes to show how the two sides of the CD rack could be joined together. Any fittings used must **not** be seen on the outside of the CD rack.

[6]

- (f) (i) Describe how you would prepare the sides of the CD rack for finishing.

.....

.....

..... [2]

- (ii) Name a suitable finish and give a reason for your choice.

Finish [1]

Reason [1]

Permission to reproduce items where third-party owned material protected by copyright is included has been sought and cleared where possible. Every reasonable effort has been made by the publisher (UCLES) to trace copyright holders, but if any items requiring clearance have unwittingly been included the publisher will be pleased to make amends at the earliest possible opportunity.

University of Cambridge International Examinations is part of the Cambridge Assessment Group. Cambridge Assessment is the brand name of University of Cambridge Local Examinations Syndicate (UCLES), which is itself a department of the University of Cambridge.