



UNIVERSITY OF CAMBRIDGE INTERNATIONAL EXAMINATIONS
International General Certificate of Secondary Education

CANDIDATE
NAME

CENTRE
NUMBER

--	--	--	--	--

CANDIDATE
NUMBER

--	--	--	--

* 7 1 2 3 5 1 2 0 6 1 *

DESIGN AND TECHNOLOGY

0445/04

Paper 4 Systems and Control

October/November 2009

1 hour

Candidates answer on the Question Paper.

No Additional Materials are required.

To be taken together with Paper 1 in one session of 2 hours and 15 minutes.

READ THESE INSTRUCTIONS FIRST

Write your Centre number, candidate number and name on all the work you hand in.

Write in dark blue or black pen.

You may use a soft pencil for any diagrams or graphs.

Do not use staples, paper clips, highlighters, glue or correction fluid.

DO NOT WRITE IN ANY BARCODES.

You may use a calculator.

Section A

Answer **all** questions.

Section B

Answer **one** question.

At the end of the examination, fasten all your work securely together.

The number of marks is given in brackets [] at the end of each question or part question.

For Examiner's Use	
Section A	
Section B	
Total	

This document consists of an **15** printed pages and **1** blank page.



Section A

Answer all questions in this section.

For
Examiner's
Use

1 Fig. 1 shows a variety of structures.

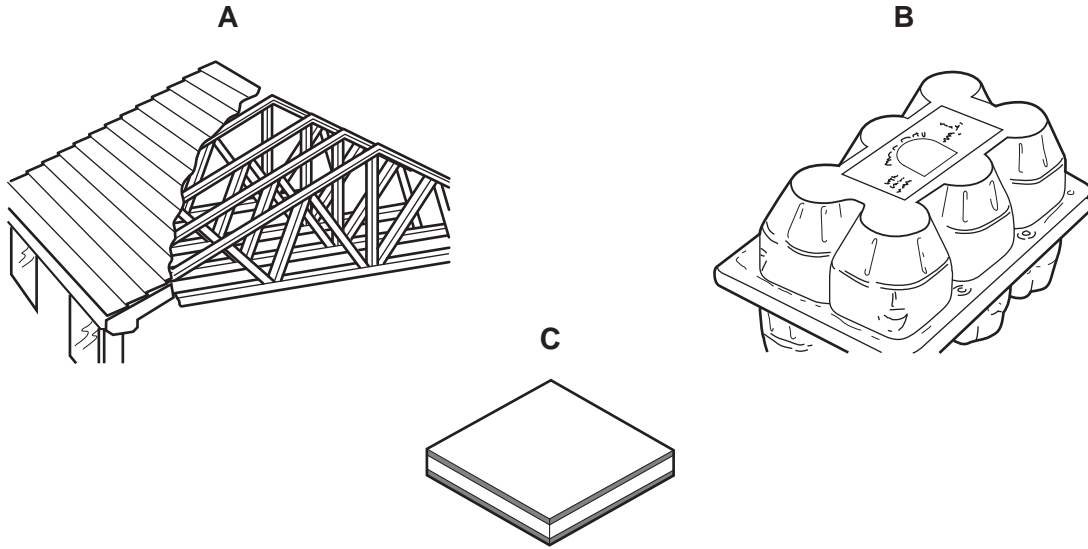

Fig. 1

(a) Identify the types of structure shown by example A and example B.

A [1]

B [1]

(b) Example C is a laminated structure.

(i) Explain one benefit of a laminated structure.

.....
.....
..... [2]

(ii) Give one example of a laminated structure.

..... [1]

2 Use notes and sketches to show a second class lever.

Clearly label the following features:

- effort;
- load;
- fulcrum.

[3]

3 Complete the table showing a selection of electrical switches and their applications.

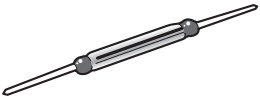
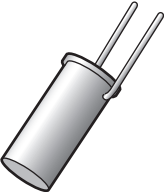
Type	Appearance	Application
[1]		Non-contact operation by magnet for detecting the opening or closing of doors/windows
Tilt		[1]
Membrane panel	[2]	Waterproof keypads

4 An LDR is a light sensing device.

(a) Sketch the circuit symbol for an LDR.

[2]

(b) Give **one** specific example of the use of an LDR.

..... [1]

5 Fig. 2 shows a gear system.

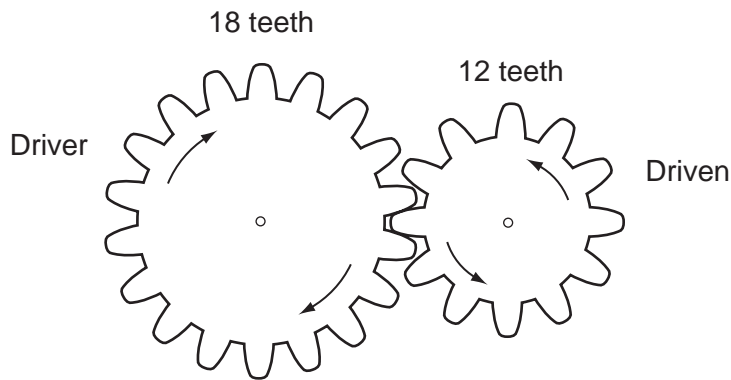

Fig. 2

(a) Calculate the speed of the driven gear if the speed of the driver is 200 rpm.

[3]

(b) Explain how the direction of rotation for the driver and driven gears can be made the same.

.....
.....
..... [2]

6 Fig. 3 shows a circuit symbol for a logic gate.

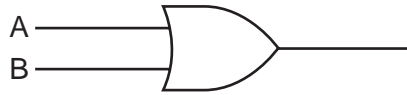

Fig. 3

Name the logic gate shown.

..... [1]

7 Fig. 4 shows a drying rail for textiles printing.

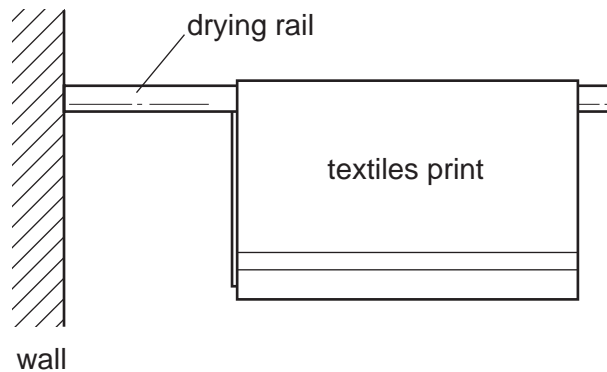

Fig. 4

Identify the type of structure shown in Fig. 4.

..... [1]

8 Fig. 5 shows detail of a bicycle handle bar and brake lever.

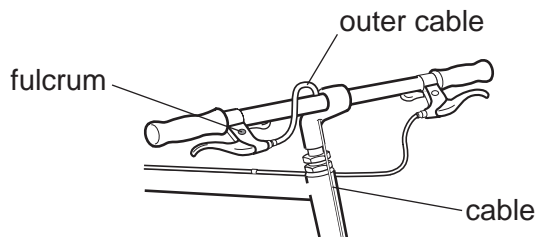

Fig. 5

Identify the class (order) of lever used as a brake lever.

..... [1]

9 Give **one** example of the use of pulleys to control speed.

..... [1]

10 State **one** reason why it is necessary to have bearings in a mechanical system.

..... [1]

Section B

Answer **one** question from this section.

For
Examiner's
Use

11 Logic gates are used to control electronic systems.

(a) Give **one** example of the use of logic gates in everyday life.

..... [1]

(b) Logic systems can be modelled using switches and light bulbs.

(i) Draw a circuit plan of switches and light bulbs for an **AND** logic system model where there are four inputs needed for one output.

[4]

(ii) Sketch the circuit symbol for a **NAND** gate.

[3]

(iii) Complete the truth table below for a **NAND** gate.

Input A	Input B	Output
0	0	1
0	1	
1		1
1		0

[3]

(c) It is decided to replace the light bulbs in the logic circuit model with LEDs.

(i) Sketch and label an LED.

[3]

(ii) When connecting an LED, it is essential to connect a resistor in series with the LED.

Explain why this is so.

.....
.....
..... [2]

(iii) Fig. 6 shows an LED and resistor connected in series.

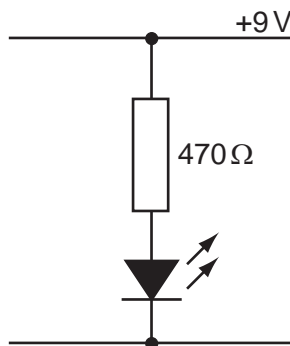

Fig. 6

Calculate the current flowing through the LED.

[3]

(iv) Give **two** advantages of using LEDs instead of light bulbs.

- 1 [1]
- 2 [1]

(v) The LED and resistor are connected in series.

Name **one** other way of connecting components.

..... [1]

(d) The table below shows the colour coding system for resistors.

Colour	1st band	2nd band	3rd band	4th band
Black	0	0	-	Assume this band is gold
Brown	1	1	0	
Red	2	2	00	
Orange	3	3	000	
Yellow	4	4	0000	
Green	5	5	00000	
Blue	6	6	000000	
Violet	7	7	0000000	
Grey	8	8	00000000	
White	9	9	000000000	

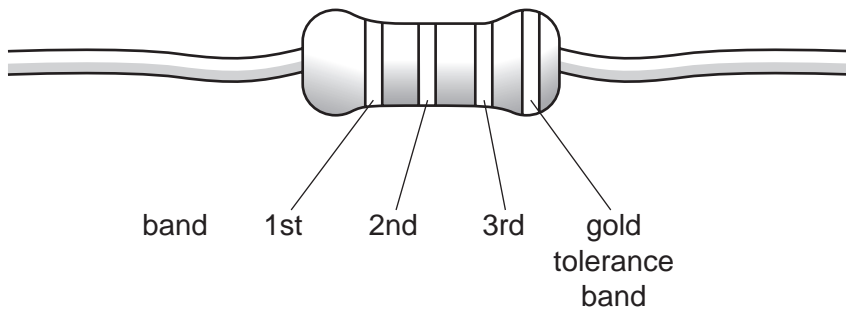

Determine the colour code for the 470 Ω resistor.

- 1st [1]
- 2nd [1]
- 3rd [1]

12 Fig. 7 shows a design for a child's mechanical toy. By pushing the head or tail of the toy the legs move as shown.

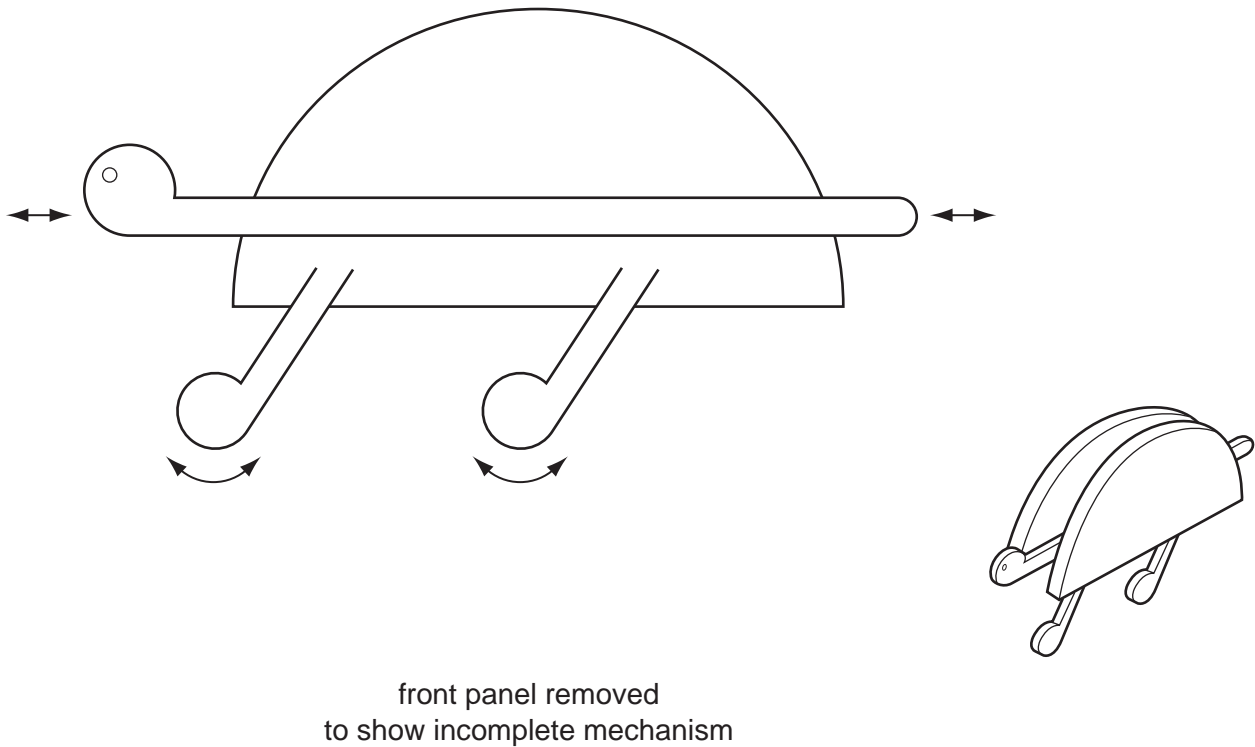

Fig. 7

(a) Name the types of motion made by the head and the legs of the toy.

Head [1]

Legs [1]

(b) Add sketches and labels to Fig. 7 to show a suitable mechanism that would move the head and legs as shown. [5]

(c) Fig. 8 shows a similar toy with an incomplete mechanism.

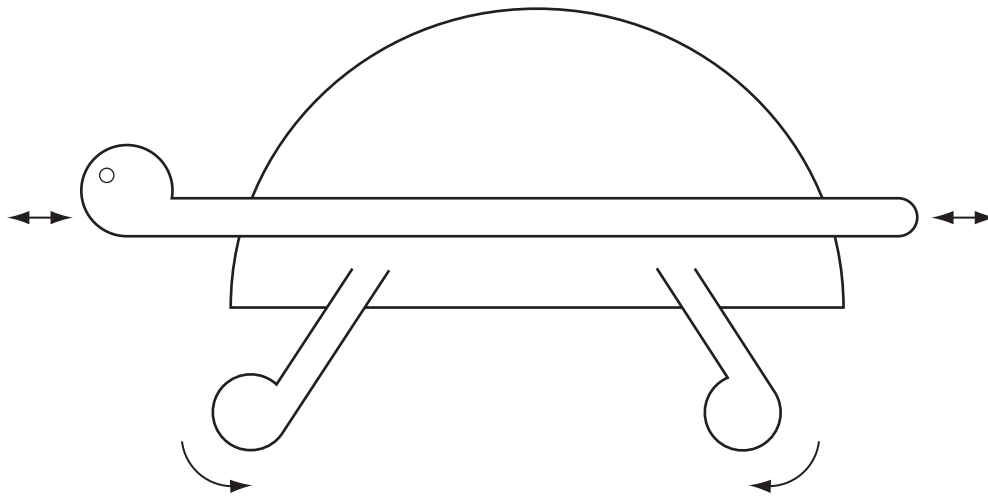

Fig. 8

- (i) Add sketches and labels to Fig. 8 to show a suitable mechanism to move the legs as shown. [4]
- (ii) Add sketches and labels to show a method for limiting the distance moved by the head of the toy. [2]
- (iii) Use sketches and notes to show how the mechanism added to Fig. 8 could be modelled prior to being manufactured. [3]

(iv) Explain why it is beneficial to model mechanisms before manufacturing from resistant materials.

.....

.....

..... [2]

(d) Fig. 9 shows a worm and wormwheel system.

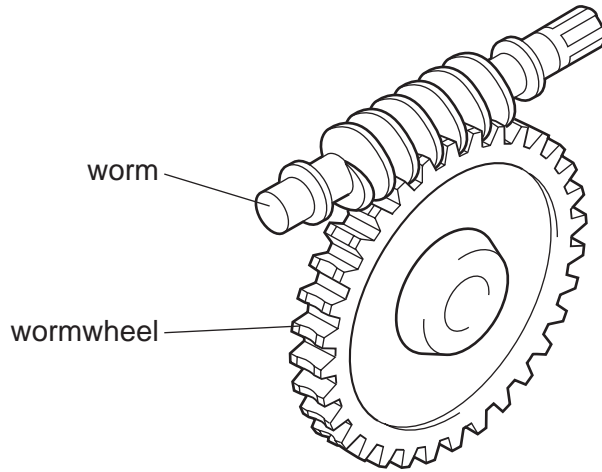

Fig. 9

(i) Give **one** example of the use of this type of gear system.

..... [1]

(ii) Explain the benefits of using this type of gear system.

.....
.....
..... [3]

(iii) The wormwheel has 40 teeth.

State the gear ratio of the system.

..... [1]

(iv) If the speed of the worm is 200 rpm, calculate the output speed from the wormwheel.

[2]

13 Fig. 10 shows a display stand used on a shop counter top.

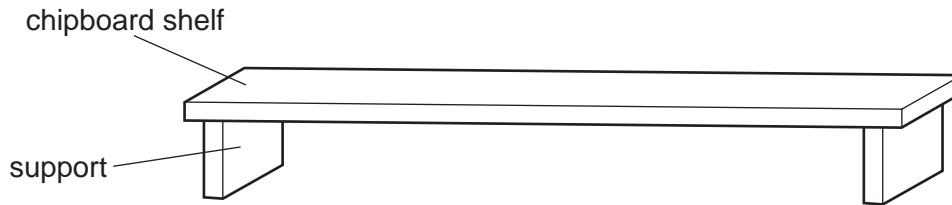

Fig. 10

(a) Consider the effects of loading the stand at its centre.

- (i)** Use sketches and notes to show where tension, compression and the neutral axis are located under loading.

[3]

- (ii)** Show, using sketches and notes, how the stand can be modified to reduce the effects of loading.

[3]

(b) Fig. 11 shows a schematic diagram of the stand loaded as shown.

For
Examiner's
Use

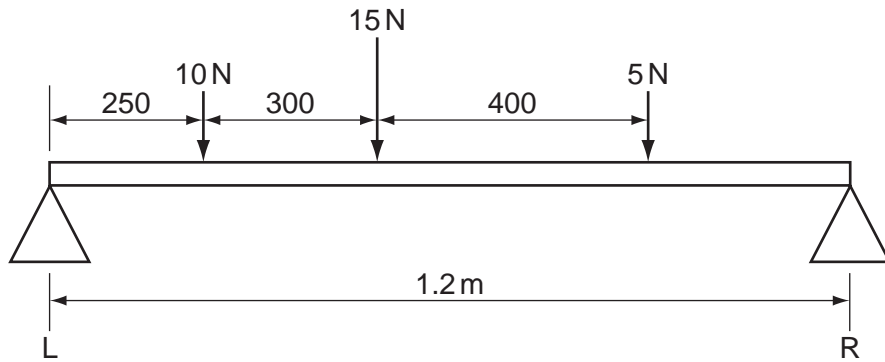

Fig. 11

Calculate the values of the reactions at L and R.

[4]

(c) It is decided to suspend the display stand from brackets in a shop window.

- (i) Use sketches and notes to show how the stand could be suspended using string so that it is in equilibrium.

[3]

- (ii) Name the force acting in the string.

..... [1]

- (iii) Explain the term 'equilibrium'.

.....

 [2]

- (iv) Fig. 12 shows a design for a bracket for supporting the display stand.

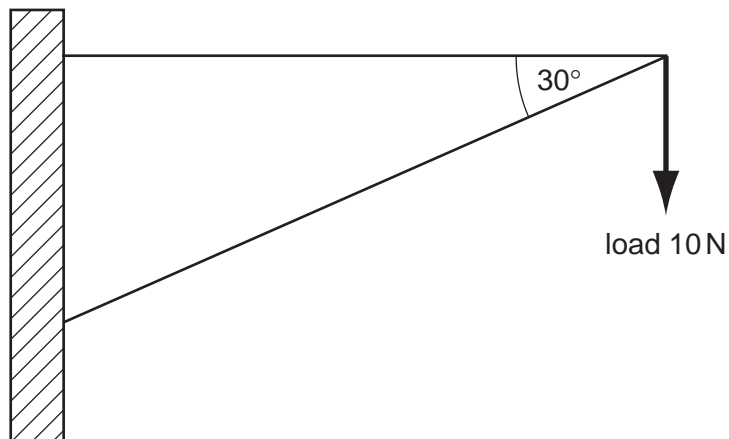

Fig. 12

For the load shown, determine the internal forces acting in the members and indicate the nature of the forces in each member.

[5]

(d) It is decided to replace the stand with a temporary structure made from corrugated cardboard.

(i) Sketch and label a cross sectional view of corrugated cardboard.

[2]

(ii) Explain the structural benefits of using corrugated cardboard for temporary structures.

.....

.....

.....

.....

..... [2]

Permission to reproduce items where third-party owned material protected by copyright is included has been sought and cleared where possible. Every reasonable effort has been made by the publisher (UCLES) to trace copyright holders, but if any items requiring clearance have unwittingly been included the publisher will be pleased to make amends at the earliest possible opportunity.

University of Cambridge International Examinations is part of the Cambridge Assessment Group. Cambridge Assessment is the brand name of University of Cambridge Local Examinations Syndicate (UCLES), which is itself a department of the University of Cambridge.