

MARK SCHEME for the October/November 2006 question paper

0445 DESIGN AND TECHNOLOGY

0445/04 Paper 4, maximum raw mark 60

This mark scheme is published as an aid to teachers and students, to indicate the requirements of the examination. It shows the basis on which Examiners were instructed to award marks. It does not indicate the details of the discussions that took place at an Examiners' meeting before marking began.

All Examiners are instructed that alternative correct answers and unexpected approaches in candidates' scripts must be given marks that fairly reflect the relevant knowledge and skills demonstrated.

Mark schemes must be read in conjunction with the question papers and the report on the examination.

The grade thresholds for various grades are published in the report on the examination for most IGCSE, GCE Advanced Level and Advanced Subsidiary Level syllabuses.

- CIE will not enter into discussions or correspondence in connection with these mark schemes.

CIE is publishing the mark schemes for the October/November 2006 question papers for most IGCSE, GCE Advanced Level and Advanced Subsidiary Level syllabuses and some Ordinary Level syllabuses.

1. (a) (i) A. Resistor [1]
 B. Light emitting diode (LED) [1]
- (ii) To control value of voltage across the LED (1) and so protect it from overload (1) [2]
- (iii) It is always 'on' (1). It is not sensitive enough (2) [2]
- (iv) Add a switch (1) between battery and probe (1) **or** add a variable resistor or transistor into circuit (2) [2]
- (b) (i) Makes the circuit quicker to react (1) to the presence of smaller amount of moisture (1) **or** increase sensitivity (2) [2]
- (ii) Base (1), Collector (1), Emitter (1) [3]
- (iii) Sets the trigger (bias) voltage of the transistor (1) so controls the switch on point of the transistor (1) [2]
- (iv) A small current through the Base circuit (1) controls the flow of a larger current through the collector/emitter circuit (1). Thus a small change can be amplified (1) [2]
- (c) (i) Interfaces (1) between low voltage circuit and higher voltage circuit (1). [2]
- (ii) Protects the transistor (1) from back EMF (1). [2]

(d) (i)





[3]

(ii)

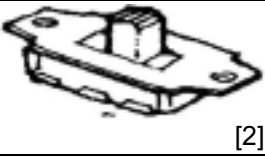

[2]

(iii) [4]

Switch	Sketch	Uses
Slide switch	 [2]	Reverse current flow to electric motors to change their direction of rotation.
Reed switch		Triggered by magnet passing by, e.g. in burglar alarms.
Push switch [1]		Switching on momentarily. [1]

Page 3	Mark Scheme	Syllabus	Paper
	IGCSE - OCT/NOV 2006	0445	4

2. (a) (i) Shear [1]
(ii) Increase (1) the c/s area (1) [2]
(iii) Twisting force e.g. ringing out a cloth (2). Sketch (1). [3]

(b) (i)

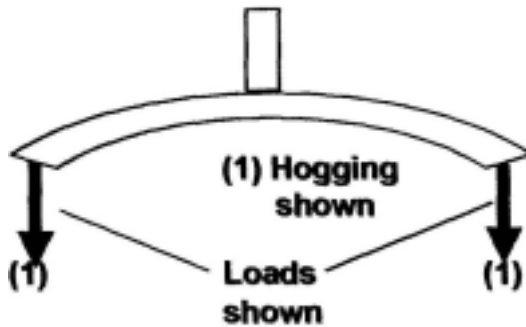

[3]

(ii)



(2)

If any metal conductor is stretched its resistance increases (1). The resistance of the conductor is directly proportional to its length (1).

[4]

- (iii) Strain = $\delta L/L = 0.0001\text{mm}/400\text{mm}$ (1)
Strain = 2×10^6 (1) units (1)

[3]

(c)

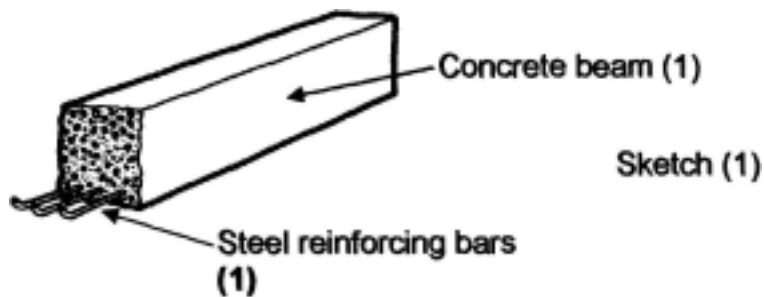

[3]

- (d) Folding a sheet (1) increases the rigidity (1)

[2]

- (e) (i) Moments @ L
 $(200 \times 20) + (500 \times 10) + (800 \times 25) = 1150 \times R$ (1)
 $4000 + 5000 + 2000/1150 = R$ (1)
 $R = 25.22 \text{ N}$ (1)
 $R + L = 55\text{N}$
 $L = 55 - 25.22 = 29.78 \text{ N}$ (1)

[4]

(ii)

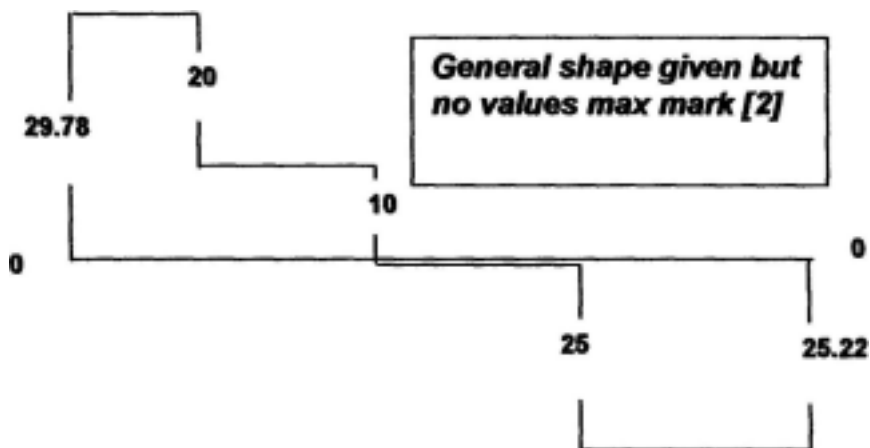

[5]

3. (a)

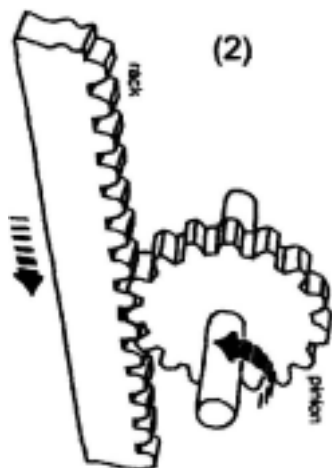

Rack and pinion (1) converts rotary into linear motion (1).

[4]

(b) (i) Screw

[1]

(ii) Converts rotary motion (1) into linear (1) Sketch (1)

[3]

(iii) Lead screw on lathe

[1]

(c)

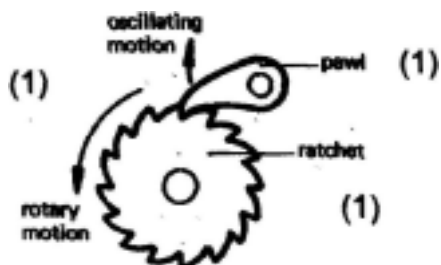

[4]

(d) (i) Fixed pivot (1), Moving pivot (1), Lever arm (1).

[3]

(ii) A system of levers (1) connected by fixed and moving pivots (1).

[2]

(iii) The long arm moves at a greater rate (1) due to the magnification effect (1) of the lever system (1). Four bar linkage ensures parallel motion (1)

[4]

Page 5	Mark Scheme	Syllabus	Paper
	IGCSE - OCT/NOV 2006	0445	4

- (e) (i) First [1]
- (ii) $2 \times 600 = X \times 200$ (1)
 $1200/200 = X$ (1)
 $X = 6m$ (1) [3]
- (iii) (Perpendicular) distance [1]
- (f) Load, (1), Effort (1), Fulcrum (1). [3]

4. (a) (i) Chemical (1) to Electrical (1) to Mechanical (1) Noise (1) [4]
- (ii) A storage device (1) holding voltage (1) [2]
- (iii) Portable (1)
Safety (1) [2]

(b)

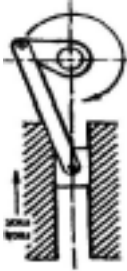
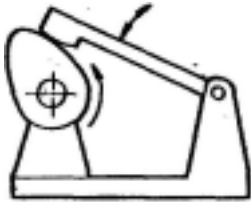
Mechanism	Sketch	Action
Spur gear	 [2]	Reduction of speed.
Crank and slider [1]		Converts rotary motion to reciprocating.
Cam and follower [1]	 [2]	Converts rotary motion into oscillating motion. [2]

- (c) (i) Overcoming the spring by hand (1) causes the staple to be pushed through (1) the spring pushes back the handle (1)
Mention of potential energy stored in the spring (2) [3]
- (ii) Effort (1), Load (1), Fulcrum (1). [3]
- (iii) Card/paper fasteners etc. (1) **or** Construction kits (1)
Feasibility of method (1)
Sketches (2) [4]

Page 6	Mark Scheme	Syllabus	Paper
	IGCSE - OCT/NOV 2006	0445	4

(d)

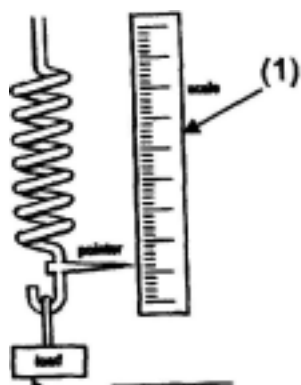

Handle of stapler
(1)

Clarity of communication (1)

Use of force meter (1)
Appropriate set up (1)
Methodology (1)

[6]