

Centre Number	Candidate Number	Name
---------------	------------------	------

UNIVERSITY OF CAMBRIDGE INTERNATIONAL EXAMINATIONS  
International General Certificate of Secondary Education

**DESIGN AND TECHNOLOGY** **0445/04**

Paper 4 Technology May/June 2005

**1 hour**

Candidates answer on the Question Paper.  
No additional materials are required.

**To be taken together with Paper 1 in one session of 2 hours 45 minutes.**

**READ THESE INSTRUCTIONS FIRST**

Write your Centre number, candidate number and name on all the work you hand in.  
Write in dark blue or black pen in the spaces provided on the Question Paper.  
You may use a soft pencil for any diagrams, graphs or rough working.  
Do not use staples, paper clips, highlighters, glue or correction fluid.

Answer any **two** questions.  
The number of marks is given in brackets [ ] at the end of each question or part question.  
You may use a calculator.

If you have been given a label, look at the details. If any details are incorrect or missing, please fill in your correct details in the space given at the top of this page.

Stick your personal label here, if provided.

For Examiner's Use	
1	
2	
3	
4	
<b>Total</b>	

- 1 Fig. 1 shows a tractor, its trailer and detail of the coupling used to connect the tractor and trailer.

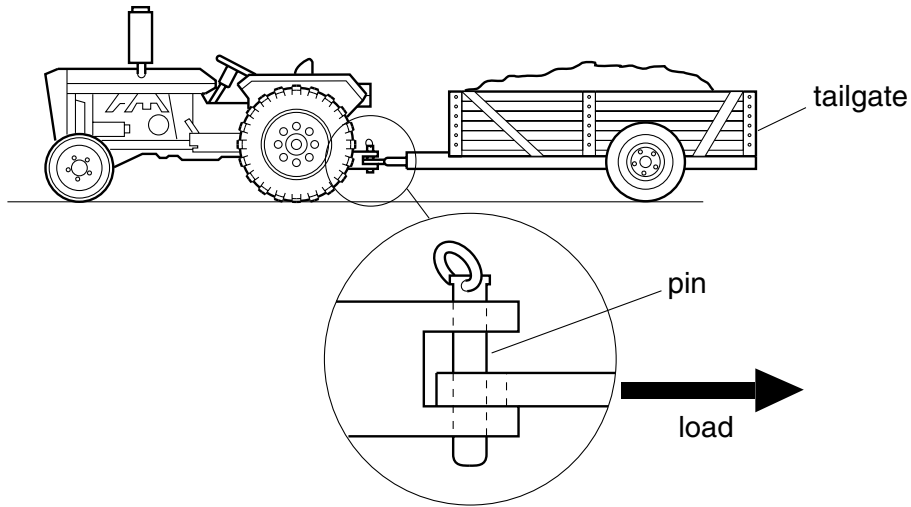

Fig. 1

- (a) (i) Name the type of force that the pin is experiencing when under load.  
..... [1]
- (ii) Describe the way in which the pin would fail if it were overloaded.  
.....  
.....  
..... [2]
- (iii) The pin is to be made from mild steel. Give **one** benefit of using mild steel for the pin.  
.....  
..... [1]
- (iv) Give **one** drawback of using mild steel for the pin.  
.....  
..... [1]

(b) (i) When the tractor is moving, its drive shaft is said to be in torsion. Describe, using sketches and notes, what is meant by the term torsion.

[3]

(ii) Give any other example of torsion.

..... [1]

(iii) Name **two** other examples of forces.

1. .... [1]

2. .... [1]

(c) When building the trailer the designer needed to think about different ways of joining the metal frame of the structure.

Complete the table below.

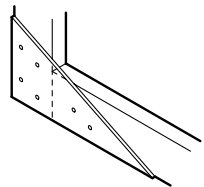
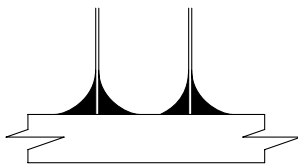
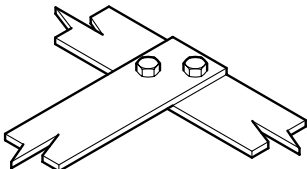
Name of joining method	Diagram	Reason for use
Gusset plate and bolts		
Welding		
Nuts and Bolts		

[6]

- (d) Fig. 2 represents a corner of the trailer frame. Use graphical means to determine the forces acting in the frame and show the nature of the forces in each member.

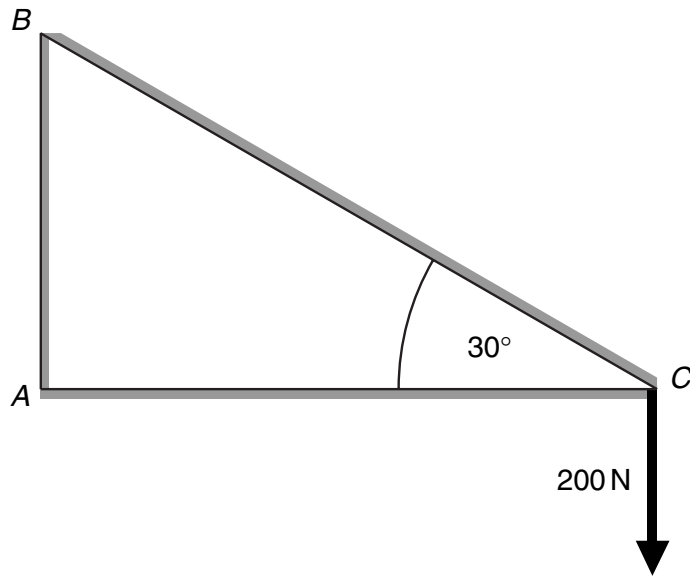
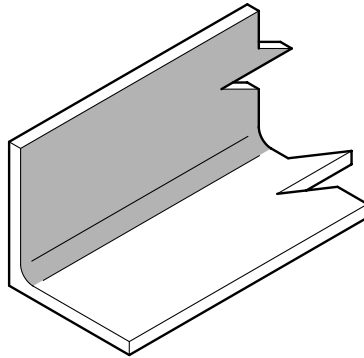

Fig. 2

[6]

(e) (i) Fig. 3 shows a section of the frame material.

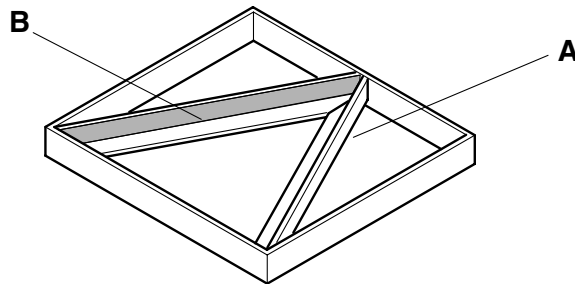

**Fig. 3**

Explain why this section shape is suitable for making the trailer frame.

.....  
.....  
..... [2]

(ii) Fig. 4 shows the tailgate of the trailer.

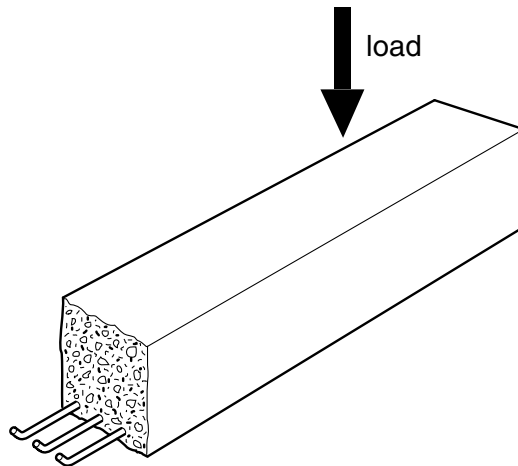

**Fig. 4**

Explain why it is necessary to add parts **A** and **B** to the tailgate.

.....  
.....  
..... [2]

(f) Fig. 5 shows a concrete beam.



**Fig. 5**

Explain why the beam is constructed in this way.

.....

.....

.....

.....

.....

..... [3]

[Total: 30 marks]

2 A strain gauge is used to measure strain in the trailer coupling in Fig. 1.

(a) (i) Explain, using sketches and notes, the principle behind the operation of a strain gauge.

[3]

(ii) As part of the testing set up a 741 operational amplifier is used.  
Complete and label Fig. 6, which shows a simple inverting amplifier circuit.

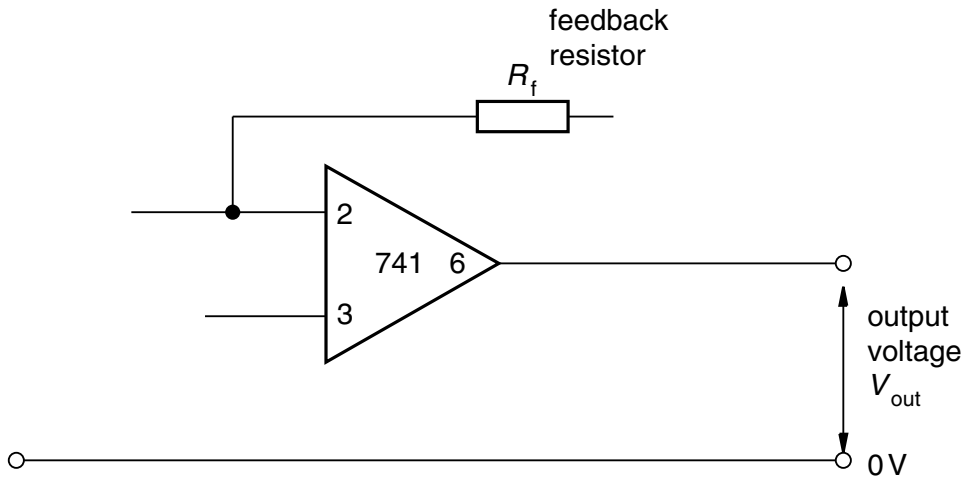

[4]

Fig. 6

(iii) Explain the need for a feedback resistor in an inverting amplifier circuit.

.....

.....

..... [2]

(iv) Explain why it is better to buy a 741 Op Amp Integrated Circuit rather than to build the amplifier from separate components.

.....  
 .....  
 ..... [2]

(b) A strain gauge is a type of transducer. Name the transducer used to sense a change in temperature levels.

..... [1]

(c) A Light Dependent Resistor is used to sense a change in light levels. Fig.7 shows a circuit plan for a light-sensing circuit.

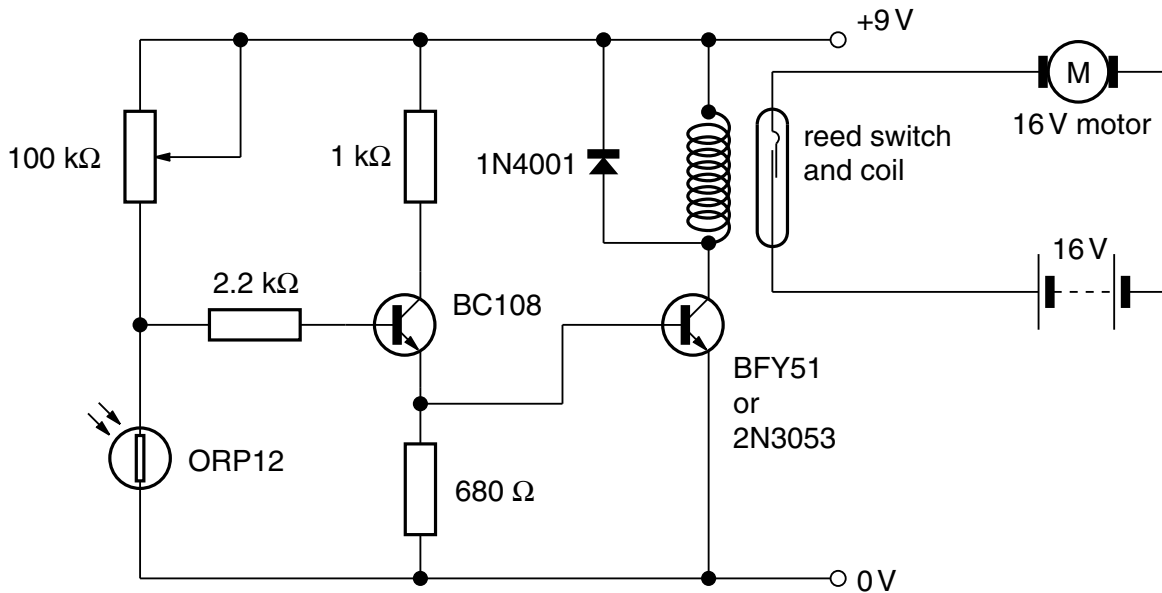

Fig. 7

(i) Explain, using sketches and notes, how a reed switch works.

[3]

(ii) Explain why there are two transistors in this circuit.

.....  
 .....  
 ..... [2]



(iii) Explain the purpose of the 100 kΩ variable resistor.

.....  
.....  
..... [2]

(iv) The circuit could be modified by using a reed relay. Draw and label a diagram of a D.I.L. Reed Relay.

[3]

(v) Use notes and sketches to show how a reed switch can be used as a proximity switch in a burglar alarm system.

[3]

(d) Fig. 8 shows a circuit to produce a time delay.

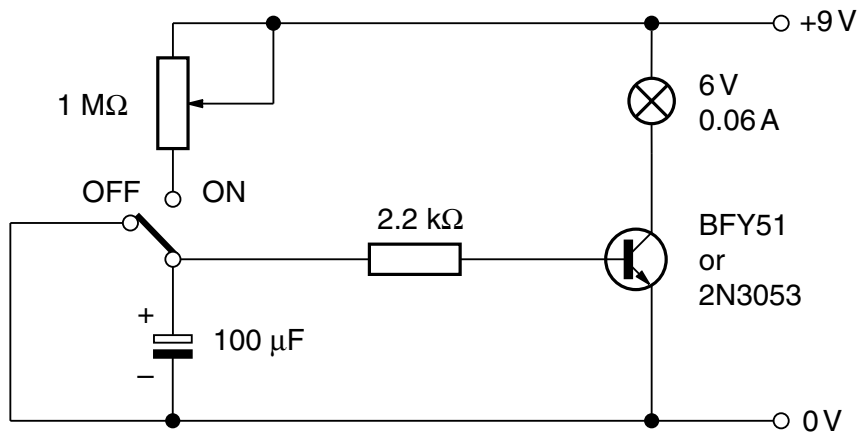

Fig. 8

(i) This circuit produces a range of time delays between 0 and 30 seconds. Explain how this is possible.

.....  
 .....  
 ..... [2]

(ii) Draw a graph to show the charging of a capacitor.



[2]

(iii) State the precaution that must be taken when connecting an electrolytic capacitor.

.....  
 ..... [1]

[Total: 30 marks]

3 During the designing of the trailer the designer uses models to help in the development of the trailer.

(a) (i) Name **two** ways of modelling the structure of the trailer.

1. ....

2. .... [2]

(ii) The structure is tested to measure its deflection under various loads. Name an accurate method for measuring deflection.

..... [1]

(iii) Members of the structure under load are said to experience moments. Explain the term moments.

.....

.....

..... [2]

(iv) Fig. 9 shows the loading of one member of the model.

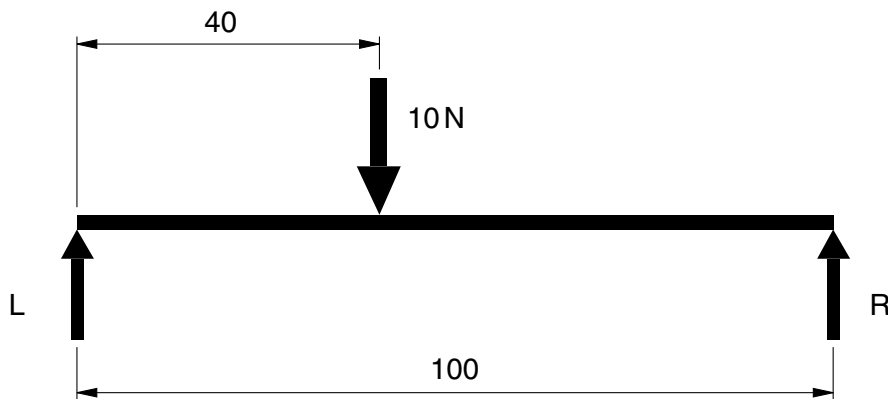

Fig. 9

Calculate the values of the reactions at **R** and **L**.

[4]

(b) (i) Name the main problem with the energy efficiency of the wheels and axle.

..... [1]

(ii) It is decided to use bearings to improve efficiency. Add labels to Fig. 10 to show the following parts:

outer race; cage; inner race; ball.

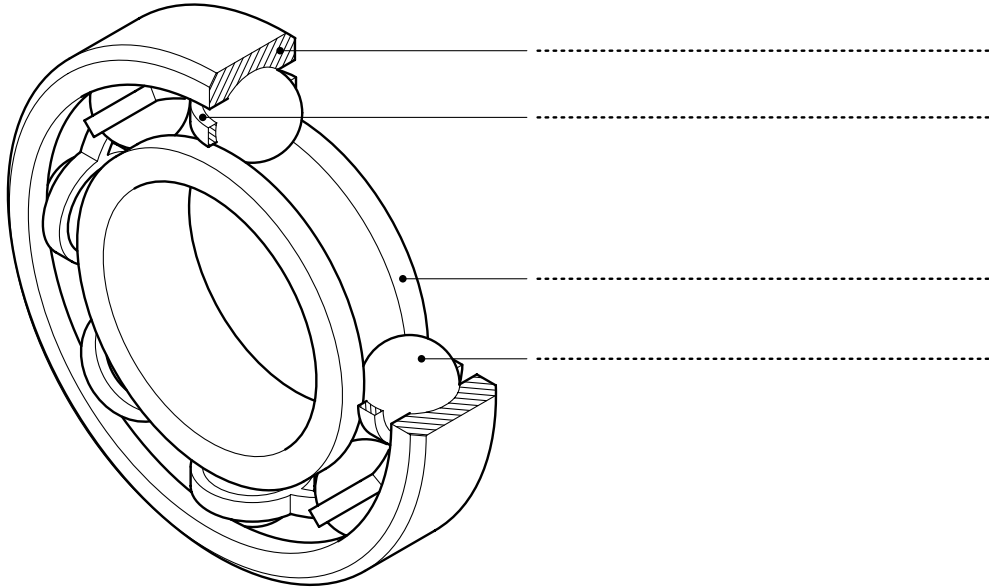

Fig. 10 [4]

(iii) Name another type of bearing.

..... [1]

(iv) Give an application for the bearing you have mentioned in (b)(iii).

..... [1]

(c) A battery-powered audio alarm is to be fitted to the trailer to warn people when the trailer is reversing.

(i) Explain what is meant by the term battery as a power source.

.....  
.....  
..... [2]

(ii) Give **one** benefit of using a battery as a power source.

.....  
..... [1]

(iii) Draw and label the circuit symbol for a battery.

[2]

(iv) Explain how a battery differs from a cell.

.....  
.....  
..... [2]

(d) When designing the alarm circuit a switch is needed that will be activated when the gear selector is moved to the reverse position.

(i) Name a suitable switch for this application.

..... [1]

(ii) A toggle switch is selected to turn the alarm unit power on and off. Draw the circuit symbol for this switch in its off position.

[2]

- (iii) Use notes and sketches to show how the switch would be fixed to a 3 mm acrylic control panel. State precautions needed to avoid cracking the acrylic control panel during fixing.

[4]

[Total: 30 marks]

4 Fig. 11 shows a mechanism that is used to open a skylight for ventilation.

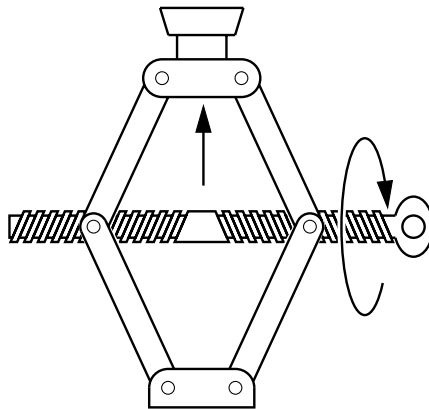

Fig. 11

(a) (i) Name the mechanism.

..... [1]

(ii) Describe the motion conversion that takes place when the mechanism is in operation.

.....  
 .....  
 ..... [2]

(iii) Give **one** drawback to using this type of mechanism.

.....  
 .....  
 ..... [2]

(iv) Use sketches and notes to show **one** way that the mechanism could be modified to make it more effective.

[4]

(b) (i) The mild steel mechanism is to be lubricated. Explain why this is necessary.

.....  
.....  
..... [2]

(ii) Suggest a suitable lubricant for this use.

..... [1]

(iii) Give **one** reason for your choice of lubricant in part (b)(ii).

.....  
.....  
..... [2]

(c) Fig. 12 shows a linkage used to open and close shutter (louvre) windows.

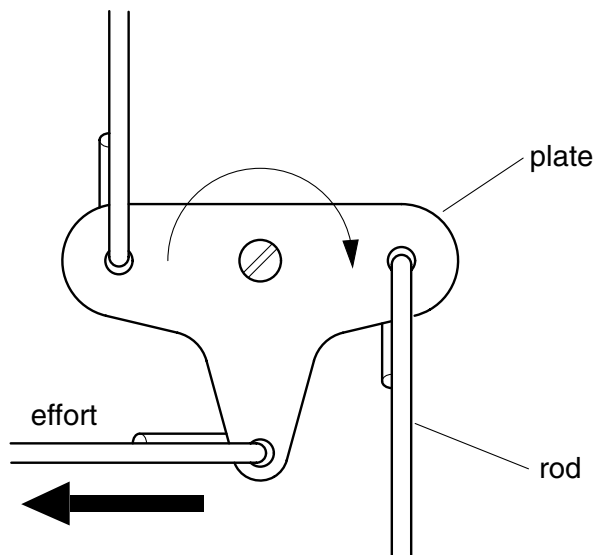

Fig. 12

(i) Add labels to Fig. 12 to show:  
load; fixed pivot; moving pivot.

[4]

(ii) The plate of the mechanism is to be made from brass. Explain why brass is selected.

.....  
.....  
..... [2]



- (iii) The rod is subjected to bending forces. Complete the diagram below to show compression, tension and the neutral axis.

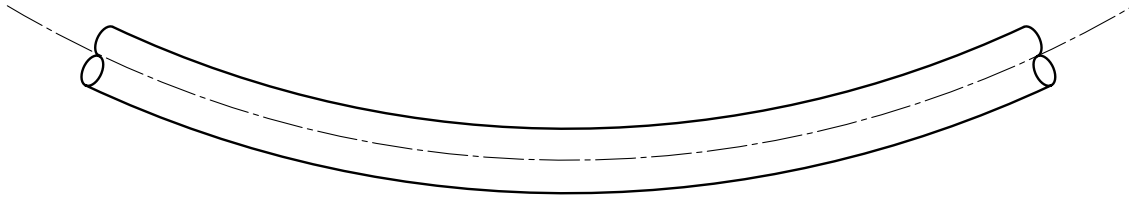

[3]

- (d) Fig. 13 shows a wheel and axle mechanism.

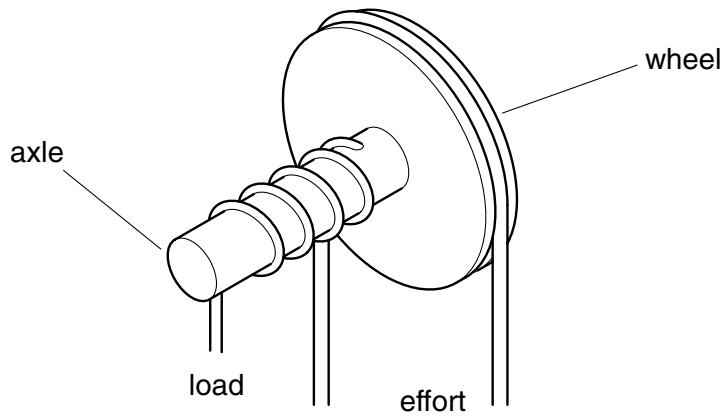

Fig. 13

- (i) If the radius of the wheel is 200 and the radius of the axle is 50 calculate the Mechanical Advantage of the wheel and axle.

[3]

- (ii) Explain how the wheel and axle makes it easier for the user to lift heavy loads.

.....

.....

..... [2]

- (iii) Calculate the effort required to lift a load of 300 N. Assume that the wheel and axle are 100% efficient.

[2]

[Total: 30 marks]



---

Every reasonable effort has been made to trace all copyright holders where the publishers (i.e. UCLES) are aware that third-party material has been reproduced. The publishers would be pleased to hear from anyone whose rights they have unwittingly infringed.

University of Cambridge International Examinations is part of the University of Cambridge Local Examinations Syndicate (UCLES), which is itself a department of the University of Cambridge.