

1 The complete end view and an incomplete front view of an information screen for a bus station are given below. A pictorial view of the monitor is given to the right.

(a) State the scale of the orthographic views.

..... [2]

(b) In the space indicated, draw the symbol for the angle of projection used for the orthographic views. [3]

(c) Complete the front view by:

(i) constructing the line of intersection between Parts A and B; both parts are cylindrical; [5]

(ii) drawing the monitor in position in the frame; hidden detail is not required. [9]

(d) Project a plan view of the complete information screen including the monitor. Hidden detail is not required. [11]

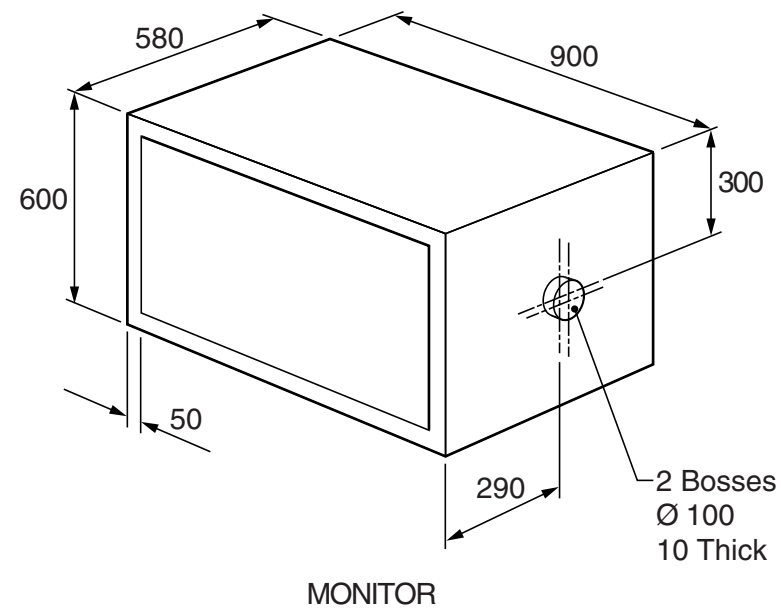

DRAW THE SYMBOL OF PROJECTION HERE

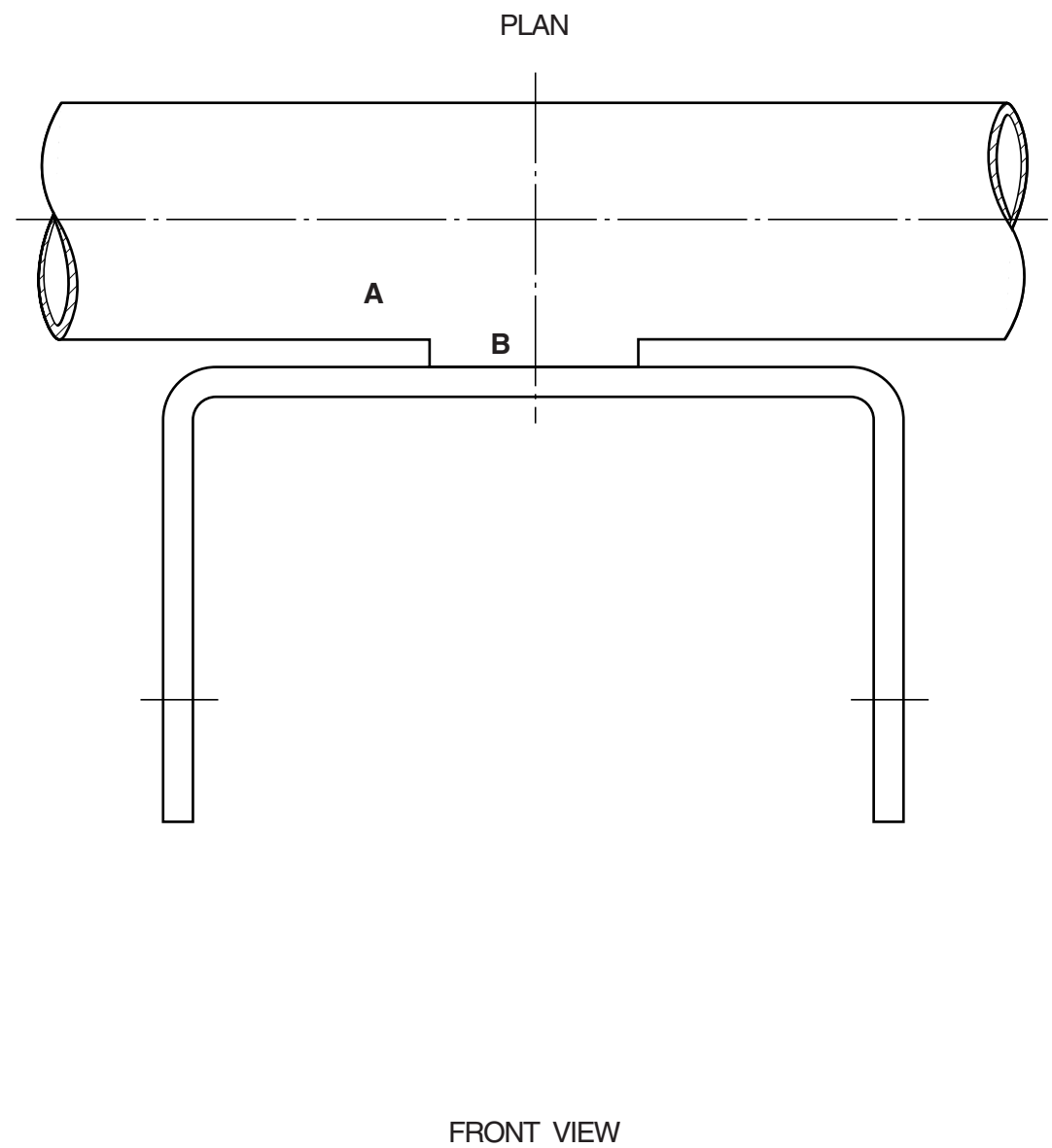
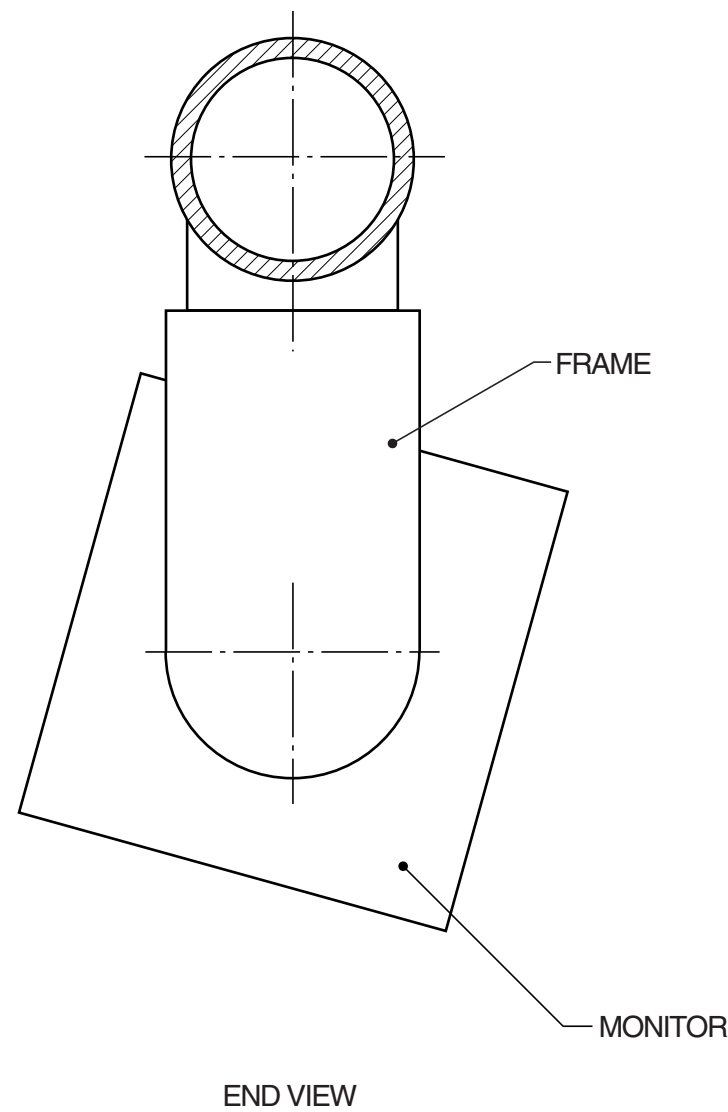

2 An illustration is needed for the electronics company HEPTAGON PRODUCTS. The illustration is to be used for publicity purposes and consists of the following:

- an ellipse 178 high and 146 wide;
- a regular heptagon circumscribing a circle;
- a pie chart in the circle giving details of the distribution of turnover between the Divisions of the company;
- the letters H and P in two squares.

Annual Company Turnover by Division

	\$
Television	152 000
Video	92 000
Audio	64 000
Telephones	36 000
Pagers	16 000

An incomplete view of the illustration is given below. Complete the illustration by:

(a) constructing the ellipse, the centre lines of which are given; [8]

(b) drawing the regular heptagon circumscribing the given circle. The base of the heptagon is horizontal; [6]

(c) constructing a pie chart in the given circle to represent the figures given to the right. [6]

(d) drawing letters H and P as large as possible in the given squares. The style of the lettering should represent an electronics company; [5]

(e) colouring your pie chart. [5]

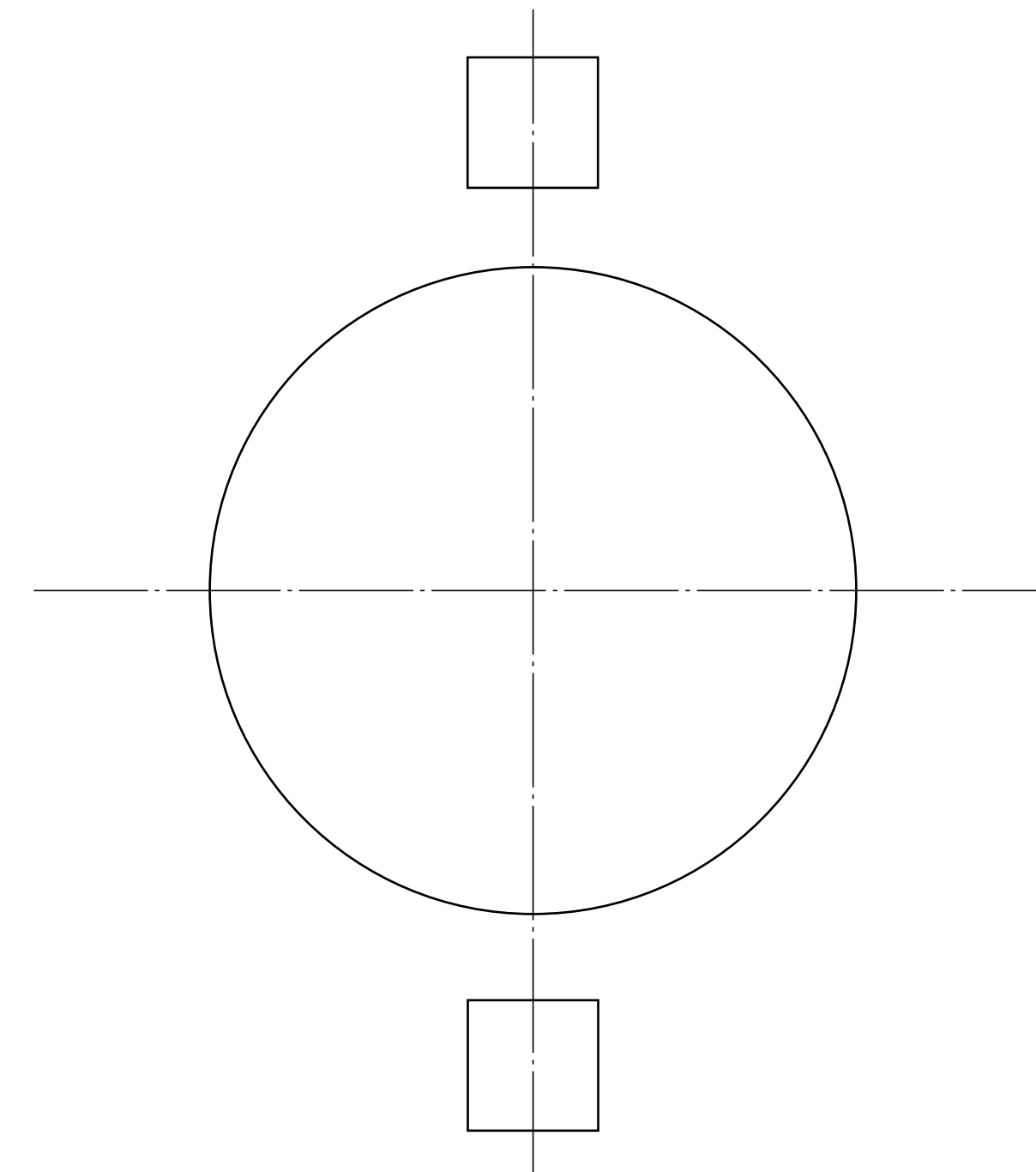

3 The pictorial view below shows a perfume bottle with a cap. Orthographic views of the bottle and cap are given to the right. The bottle is to be sold in a thin card container which fits tightly against the six sides of the bottle and is tall enough to include the cap.

- (a) Complete the orthographic view by projecting a plan view. [5]
- (b) In the position indicated, construct a one-piece development (net) of the container. Include gluing and other flaps. [15]
- (c) The perfume is called **STARLIGHT**. In the positions indicated:
- (i) draw design sketches of **two** ideas for a logo for the perfume; [3]
 - (ii) draw accurately your chosen idea for the logo on the given front view of the bottle to the right; [5]
 - (iii) colour the logo only. [2]

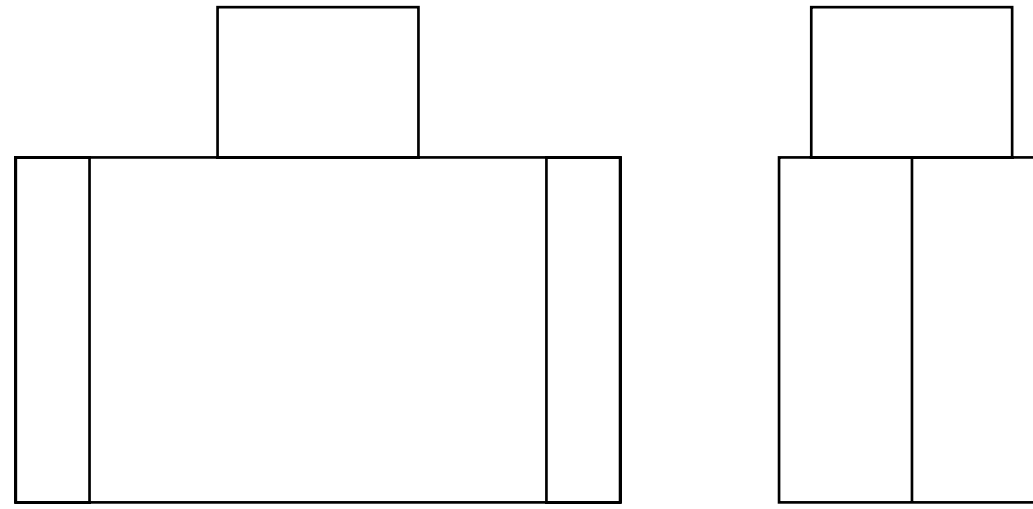
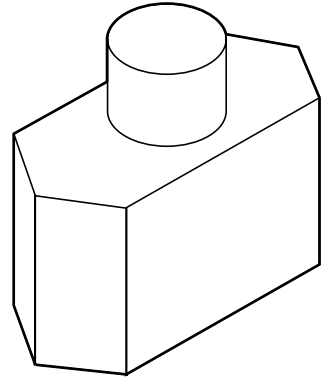

SCALE 1:1

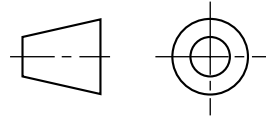

DRAW DESIGN SKETCHES HERE

DRAW THE DEVELOPMENT HERE

4 A mould for the plaster-cast stand of an ornament consists of four pieces of wood held together by bolts and nuts. Details of the parts are given to the right. The four pieces of wood are assembled with part 1 at the back followed by part 2, then part 3 and then part 4 at the front. The bolts are passed through the 8 mm diameter holes with the round head of each bolt to the front.

In the positions indicated:

- (a) draw to a scale of 1:2 an **isometric** view of the assembled mould; the position of corner **C** is given; show only **one** bolt in position; [14]
- (b) pencil shade your drawing to show that
- (i) the mould is made from four separate pieces of wood; [3]
 - (ii) the bolt head is made from polished metal; [4]
- (c) to approximately the same scale, sketch freehand a view of the plaster-cast stand that would be formed in the mould. [9]

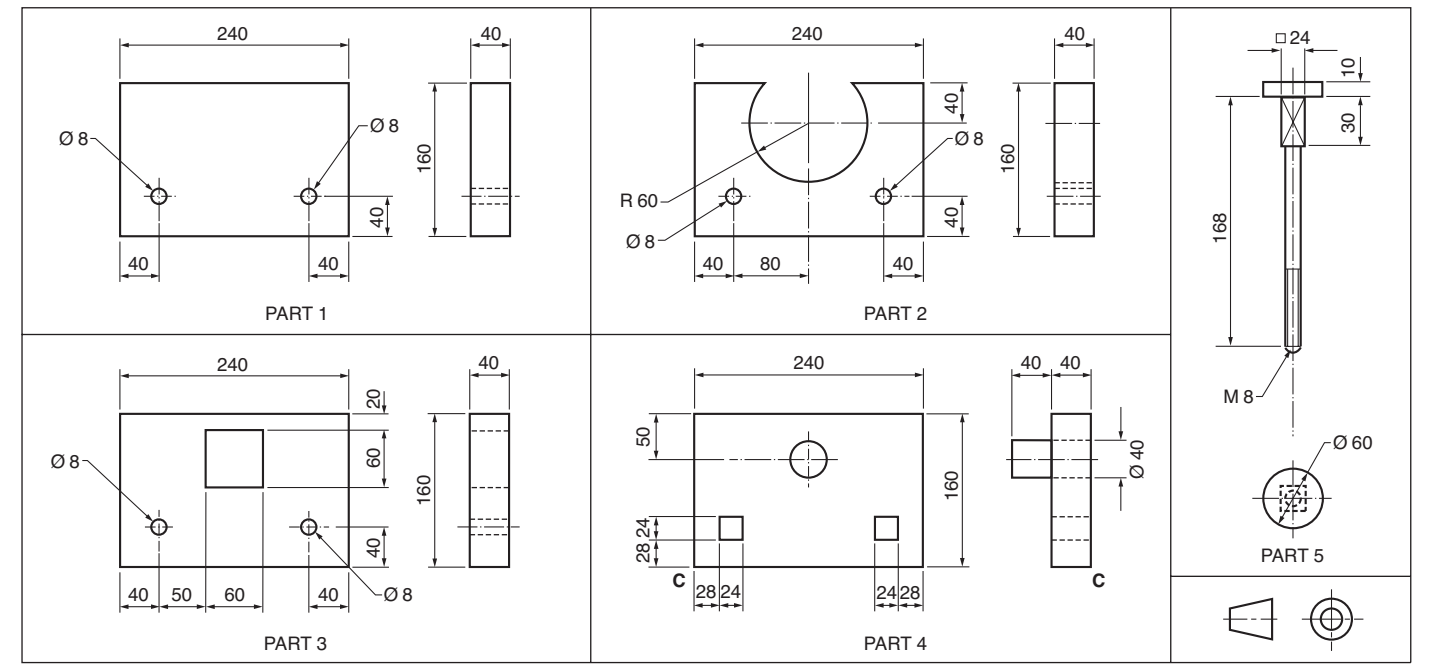

ANSWER (a) AND (b) HERE

ANSWER (c) HERE

