

Centre Number	Candidate Number	Name
---------------	------------------	------

UNIVERSITY OF CAMBRIDGE INTERNATIONAL EXAMINATIONS
International General Certificate of Secondary Education

DESIGN AND TECHNOLOGY **0445/03**

Paper 3 Realisation October/November 2004

1 hour

Candidates answer on the Question Paper.
No additional materials are required.

To be taken together with Paper 1 in one session of 2 hours 45 minutes.

READ THESE INSTRUCTIONS FIRST

Write your Centre number, candidate number and name on all the work you hand in.
Write in dark blue or black pen in the spaces provided on the Question Paper.
You may use a soft pencil for any diagrams, graphs or rough working.
Do not use staples, paper clips, highlighters, glue or correction fluid.

Answer any **two** questions.
The number of marks is given in brackets [] at the end of each question or part question.
You may use a calculator.

If you have been given a label, look at the details. If any details are incorrect or missing, please fill in your correct details in the space given at the top of this page.

Stick your personal label here, if provided.

For Examiner's Use	
1	
2	
3	
4	
TOTAL	

1 Fig. 1 shows an exploded view of the contents of a flat pack kit for a set of shelves.

(a) There are **seven** separate parts in the kit.

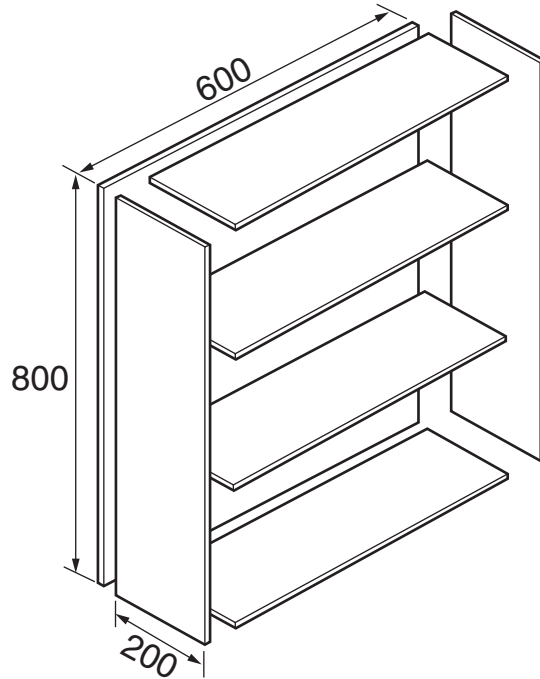

Fig. 1

Complete the parts list in the table below.

quantity	length	width	description
1	800	600	back

[4]

(b) State a suitable manufactured board for:

(i) the shelves and sides;

.....[1]

(ii) the back.

.....[1]

(c) Suggest suitable thicknesses for:

(i) the back;

.....[1]

(ii) the sides;

.....[1]

(iii) the shelves.

.....[1]

(d) Details of a plastic fixing are shown in Fig. 2. Three screws are required to fix each piece.

(i) How many fixing blocks are required to assemble the shelves?

.....[1]

(ii) How many screws are required?

.....[1]

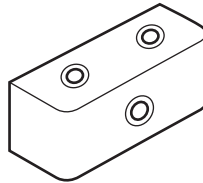

Fig. 2

(e) State how you could fix the back to the frame.

.....[1]

- (f) (i) Using notes and sketches, design an instruction sequence, showing in **four** stages how to assemble the kit. Use the boxes provided.

[8]

- (ii) Make a list of tools/aids needed to complete the assembly.

.....
.....[4]

(g) (i) Give **two** advantages of fixing a back to the shelves.

.....
.....[2]

(ii) Using notes and sketches, show how the shelves could be made adjustable.

[4]

2 Fig. 3 shows a holder, used for information leaflets. The product is made from sheet metal.

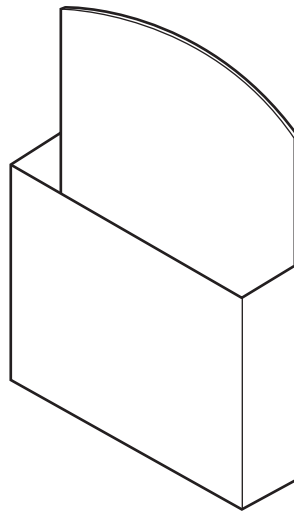

Fig. 3

(a) Give **two** reasons why sheet metal would be a suitable material for the leaflet holder.

.....
.....[2]

(b) Using notes and sketches, show how the main body could be marked out on one piece of sheet metal.

[8]

(c) Name and sketch **two** tools that could be used to mark out the shape.

1.

[4]

2.

[4]

(d) Use notes and sketches to show the following stages in producing and forming the finished holder.

(i) cut the sheet metal to shape

[3]

(ii) make the edges of the metal safe

[3]

(iii) bend the metal into the shape required

[3]

(iv) join the sides to each other to finish the product without using heat

[3]

- 3 Fig. 4 shows a child's easel made mainly from wood. It consists of two identical frames hinged at the top.

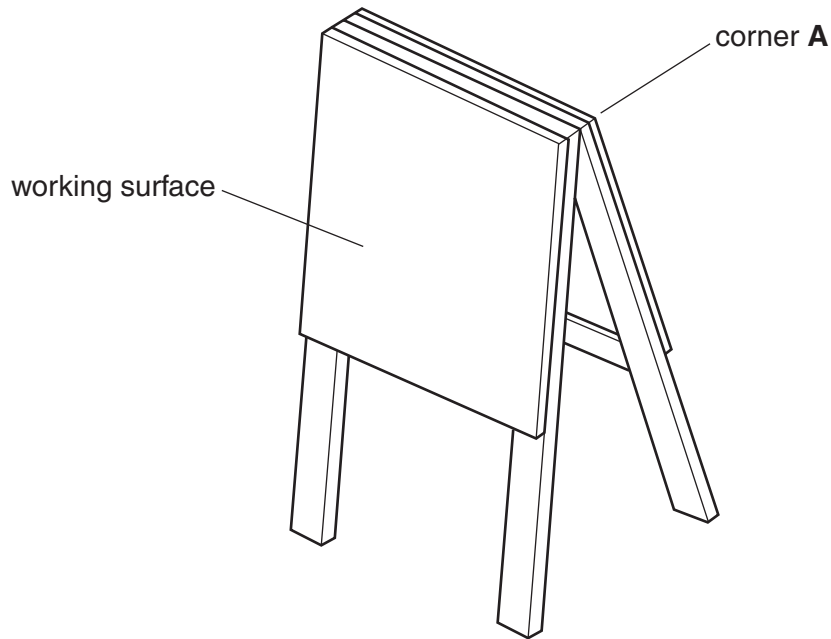

Fig. 4

- (a) (i) Draw the basic outline for **one** of the frames. Do not include any joint details.

[4]

- (ii) Name appropriate materials required to make the frame and working surface.

Frame

Working surface[2]

(iii) Show clearly how the frame could be constructed at corner **A**.

[4]

(iv) State how you could fix the working surface to the frame.

.....

.....

[2]

(v) Using notes and sketches, show how the two frames could be hinged together.

[4]

(b) Design an addition to the easel to hold **four** paint pots shown in Fig. 5.

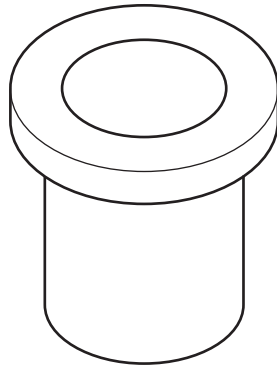

Fig. 5

[6]

- (c) Using notes and sketches, show clearly how the two frames could be securely locked in position when the easel is in use. Details of the materials and components used must be included in your solution.

[8]

4 Fig. 6 shows a wooden puzzle suitable for small children.

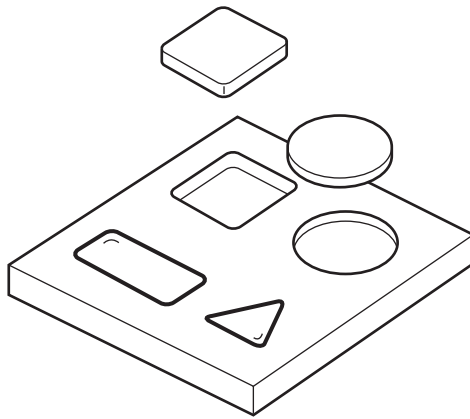

Fig. 6

(a) Suggest a specific material for:

(i) the base;

.....[1]

(ii) the geometrical shapes.

.....[1]

(b) Describe a method of making the base and forming the recess for the shapes.

.....
.....
.....
.....[6]

(c) (i) Describe **four** stages for making **one** of the shapes.

1

2

3

4[4]

(ii) List **six** tools required to produce the shape.

- 1
- 2
- 3
- 4
- 5
- 6[6]

(d) The shapes are difficult to lift out of the base.

Using notes and sketches, show an improvement to the design which will overcome this problem.

[4]

(e) If the toy were to be mass produced using plastic, name a suitable process for forming:

(i) the base

.....

(ii) the shapes

.....[2]

(f) Give **one** advantage of using plastic to make a child's puzzle.

.....

.....[2]

Question 4 continues over the page.

- (g) With the use of notes and sketches, suggest a way of keeping the shapes securely in place when being used as a travel game.

[4]