



Cambridge International Examinations
Cambridge International General Certificate of Secondary Education

CO-ORDINATED SCIENCES

0654/13

Paper 1 Multiple Choice (Core)

October/November 2018

45 minutes

Additional Materials: Multiple Choice Answer Sheet
Soft clean eraser
Soft pencil (type B or HB is recommended)



READ THESE INSTRUCTIONS FIRST

Write in soft pencil.

Do not use staples, paper clips, glue or correction fluid.

Write your name, Centre number and candidate number on the Answer Sheet in the spaces provided unless this has been done for you.

DO NOT WRITE IN ANY BARCODES.

There are **forty** questions on this paper. Answer **all** questions. For each question there are four possible answers **A, B, C** and **D**.

Choose the **one** you consider correct and record your choice in **soft pencil** on the separate Answer Sheet.

Read the instructions on the Answer Sheet very carefully.

Each correct answer will score one mark. A mark will not be deducted for a wrong answer.

Any rough working should be done in this booklet.

A copy of the Periodic Table is printed on page 16.

Electronic calculators may be used.

This document consists of **16** printed pages.

- 1 One way to test for microscopic life in soil is to see if carbon dioxide is released.

Which characteristic of living things is being tested?

- A growth
- B nutrition
- C reproduction
- D respiration

- 2 The diagram shows two cells.

Which labelled part might contain chloroplasts?

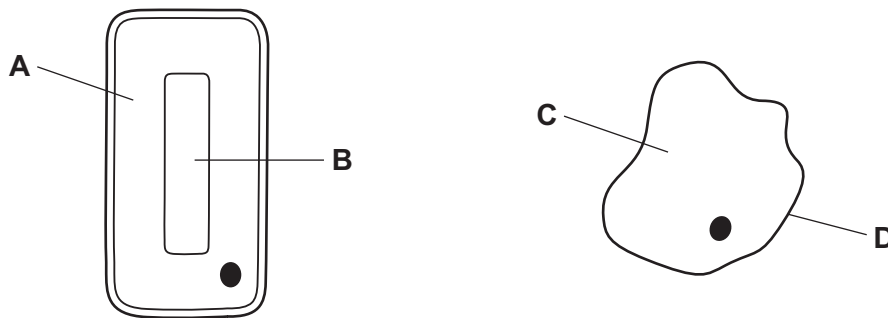

- 3 Some bacteria live in acidic, hot springs.

What are the optimum conditions for the enzymes of these bacteria?

- A 20 °C and pH 4
- B 20 °C and pH 9
- C 80 °C and pH 4
- D 80 °C and pH 9

- 4 During which food test is heat required?

- A fats
- B protein
- C reducing sugars
- D starch

5 The diagram shows a section through a leaf.

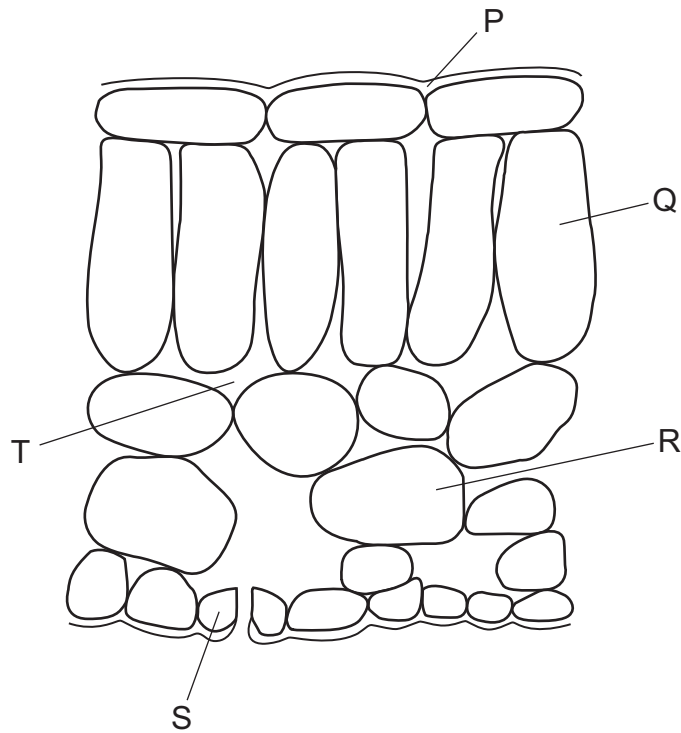

Which structures contain chloroplasts?

- A** P, Q and R **B** Q, R and S **C** R, S and T **D** S, T and P

6 Which statement about the pulmonary artery is correct?

- A** It carries deoxygenated blood away from the heart.
B It carries deoxygenated blood towards the heart.
C It carries oxygenated blood away from the heart.
D It carries oxygenated blood towards the heart.

7 What is the word equation for aerobic respiration?

- A** carbon dioxide + glucose → oxygen + water
B carbon dioxide + water → oxygen + glucose
C oxygen + glucose → carbon dioxide + water
D oxygen + water → carbon dioxide + glucose

- 8 To which environmental stimulus is a plant root responding when it grows downwards?
- A a decrease in soil water content
 - B light falling on the leaves of the plant
 - C rising temperature
 - D the force of gravity
- 9 Which name is given to the maintenance of a constant internal environment in the human body?
- A absorption
 - B diffusion
 - C egestion
 - D homeostasis
- 10 Which part of a flower produces pollen grains?
- A anther
 - B ovary
 - C sepal
 - D stigma
- 11 In pea plants, the allele for purple flowers is dominant to the allele for white flowers.
- Two heterozygous purple-flowered plants are crossed.
- What will be the expected flower colour of the offspring plants?
- A all purple
 - B all white
 - C 1 purple : 1 white
 - D 3 purple : 1 white
- 12 Species of frogs which live in trees have sticky pads on their feet. These are absent in frogs which live in other habitats.
- By which process has this come about?
- A artificial selection
 - B conservation
 - C monohybrid inheritance
 - D natural selection

13 The diagram shows part of the carbon cycle.

Which arrow represents plant respiration?

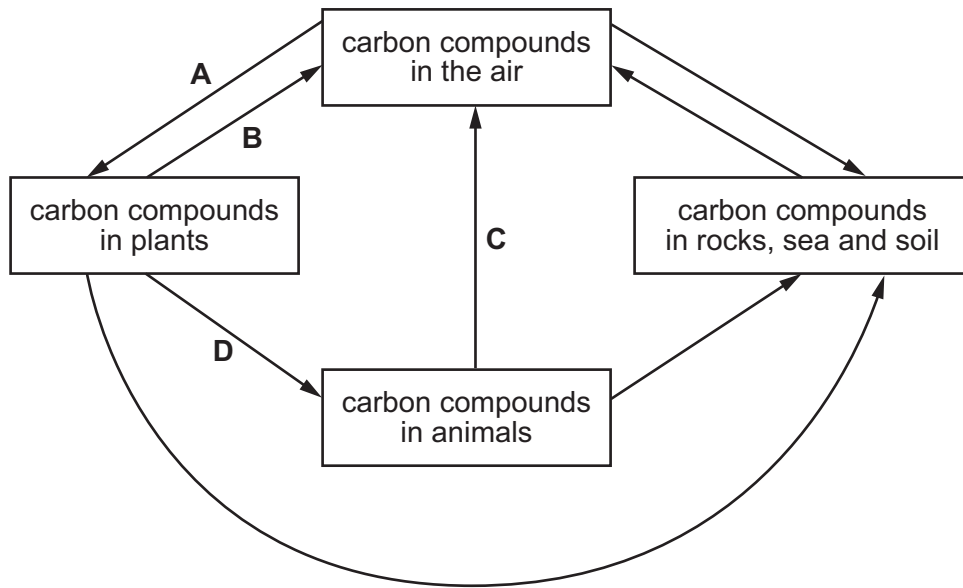

14 W, X, Y and Z are diagrams representing atoms and molecules.

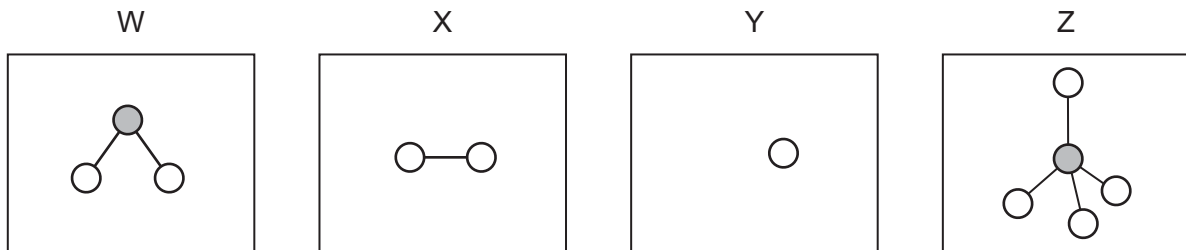

Which statement is correct?

- A W and Z are molecules and X and Y are atoms.
- B W, X and Z are molecules and Y is an atom.
- C W, Y and Z are molecules and X is an atom.
- D X, Y and Z are molecules and W is an atom.

15 Hexane and octane are liquid hydrocarbons that mix together.

Which apparatus is used to separate a mixture of these two liquids?

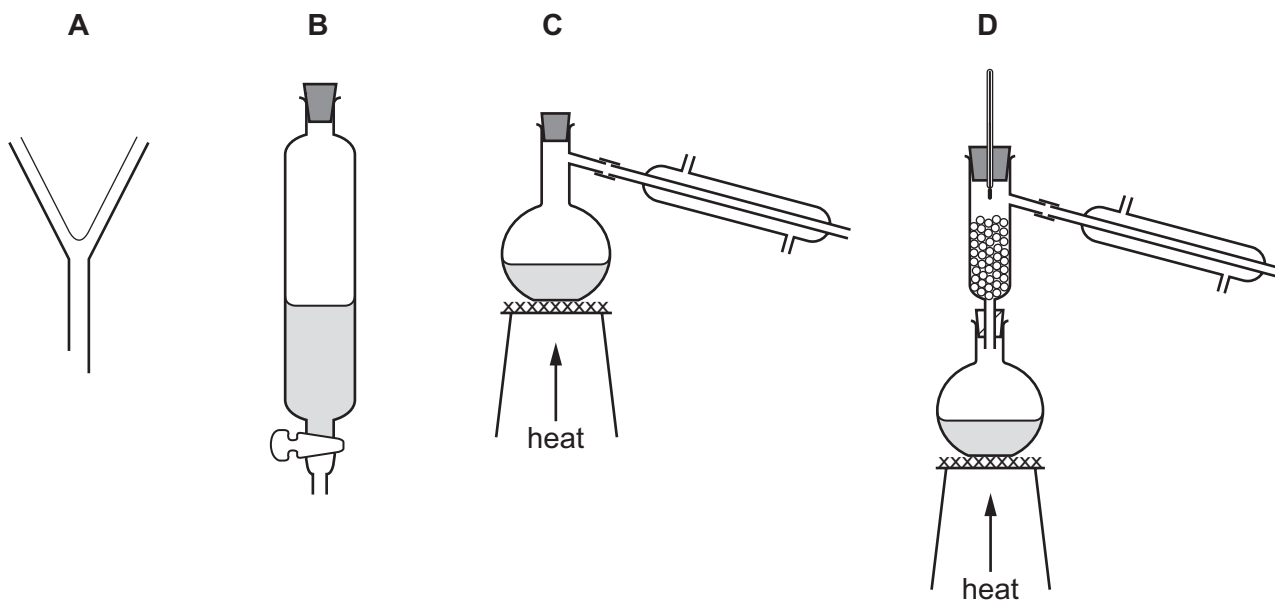

16 An atom of sodium is represented by ${}_{11}^{23}\text{Na}$.

Which row shows the number of protons and the number of neutrons in this atom?

	number of protons	number of neutrons
A	11	12
B	11	23
C	12	11
D	12	23

17 Which substance does **not** undergo electrolysis?

- A** aqueous copper chloride
- B** copper wire
- C** dilute sulfuric acid
- D** molten lead(II) bromide

18 Solid sodium hydroxide reacts with dilute hydrochloric acid.

Which change shows that the reaction is exothermic?

- A A gas is produced.
- B The mass increases.
- C The pH increases.
- D The temperature increases.

19 Dilute sulfuric acid reacts with a piece of zinc.

Which change does **not** increase the rate of reaction?

- A Use a catalyst.
- B Use a larger volume of dilute sulfuric acid.
- C Use an equal volume of more concentrated sulfuric acid.
- D Use the same mass of powdered zinc.

20 Iron oxide reacts with carbon monoxide.

The word equation is



Which statement describes what happens to the iron oxide?

- A It is oxidised because it gains oxygen.
- B It is oxidised because it loses oxygen.
- C It is reduced because it gains oxygen.
- D It is reduced because it loses oxygen.

21 An oxide of element X neutralises a dilute acid.

What is X?

- A carbon
- B hydrogen
- C magnesium
- D sulfur

22 Which statement describes a transition metal?

- A It has a high melting point, high density and forms a blue coloured sulfate.
- B It has a high melting point, high density and forms a white coloured chloride.
- C It has a high melting point, low density and forms a yellow coloured sulfate.
- D It has a low melting point, low density and forms a white coloured nitrate.

23 Which row does **not** link a general physical property to the type of element?

	type of element	general physical property
A	metal	malleable
B	metal	thermal conductor
C	non-metal	electrical conductor
D	non-metal	low melting point

24 Why is filtration used in the purification of water?

- A to crystallise dissolved salts
- B to kill bacteria
- C to remove insoluble particles
- D to remove soluble substances

25 The diagram shows gas P being passed through liquid X and over iron filings.

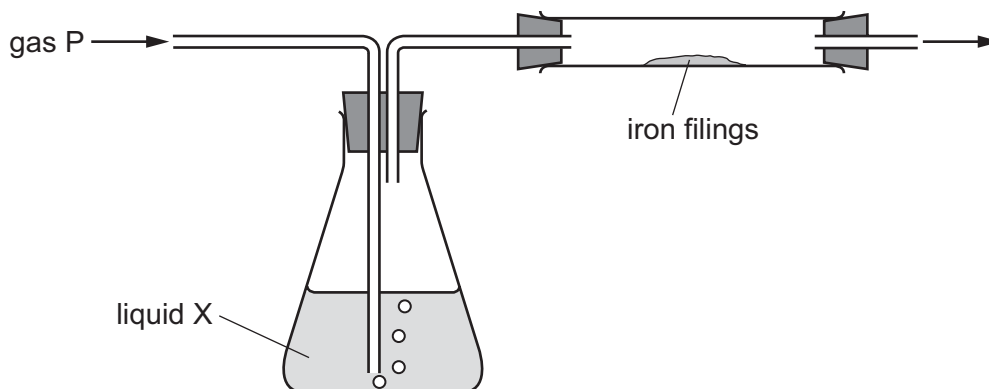

Which gas and liquid cause the iron to rust?

	gas P	liquid X
A	nitrogen	concentrated sulfuric acid (a drying agent)
B	nitrogen	water
C	oxygen	concentrated sulfuric acid (a drying agent)
D	oxygen	water

26 Which chemical is used to reduce the acidity of soil?

- A** ammonium nitrate
- B** calcium oxide
- C** magnesium sulfate
- D** potassium chloride

27 Ethene molecules are monomer units. They react together to form a large molecule.

What is this type of reaction?

- A** addition polymerisation
- B** cracking
- C** decomposition
- D** redox

28 The diagram shows a distance-time graph for a journey.

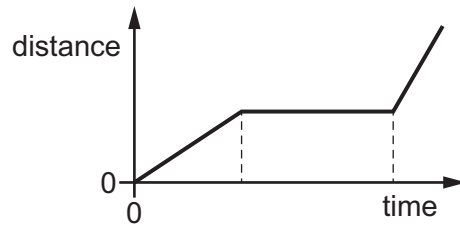

Which is the speed-time graph for this journey?

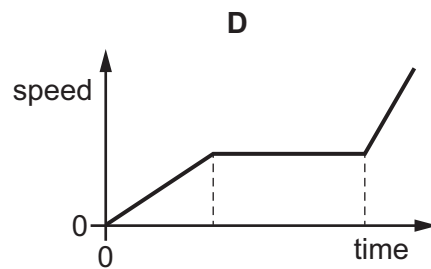
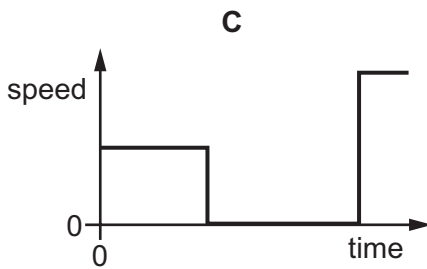
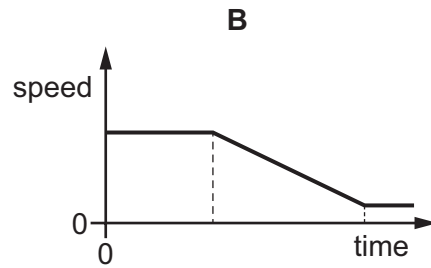
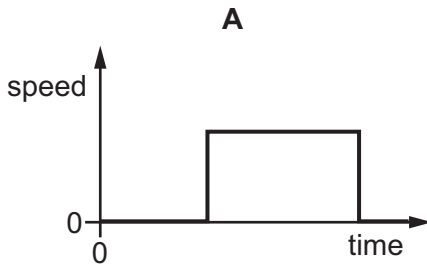

29 The diagrams show all the forces acting on each of four objects.

Which object is **not** in equilibrium?

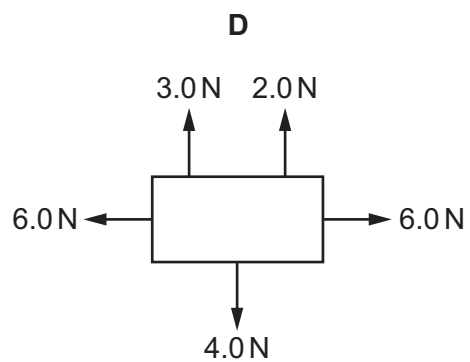
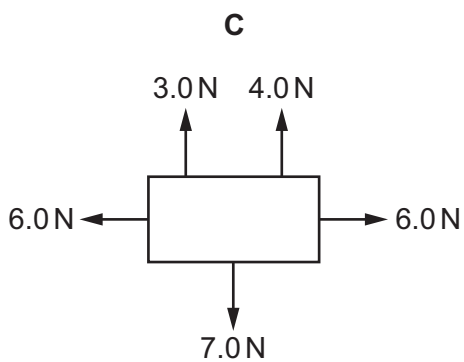
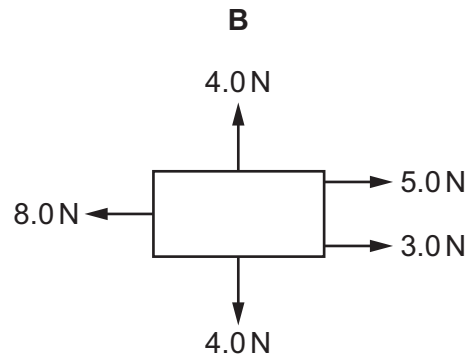
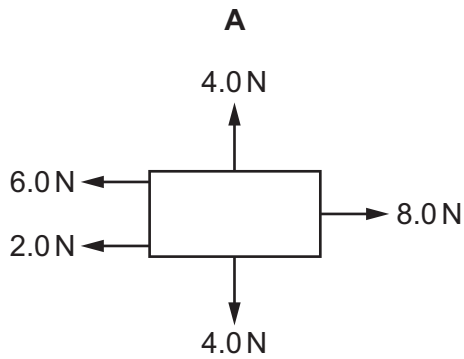

30 Which row gives a unit for energy and a unit for power?

	energy	power
A	joule	newton
B	joule	watt
C	watt	joule
D	watt	ohm

31 A gas is trapped in a container of constant volume. The temperature of the gas increases.

What happens to the speed of the molecules, and what happens to the pressure of the gas?

	speed of molecules	pressure
A	decreases	decreases
B	decreases	increases
C	increases	decreases
D	increases	increases

32 An axle is slightly larger than the hole in a wheel made from the same metal.

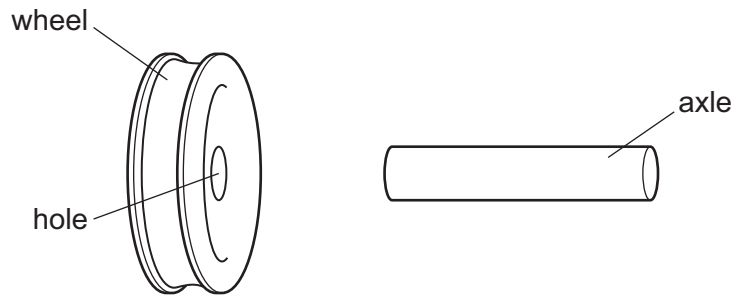

How could an engineer fit the wheel onto the axle?

- A cool the axle only
 - B cool the axle and cool the wheel by the same temperature change
 - C heat the axle only
 - D heat the axle and heat the wheel by the same temperature change
- 33 There is a vacuum between the double walls of a vacuum flask.

Which types of heat transfer are reduced by the vacuum?

- A conduction, convection and radiation
- B conduction and convection only
- C conduction and radiation only
- D convection and radiation only

- 34 The ray diagram shows two rays of light that have passed from an object through a converging lens.

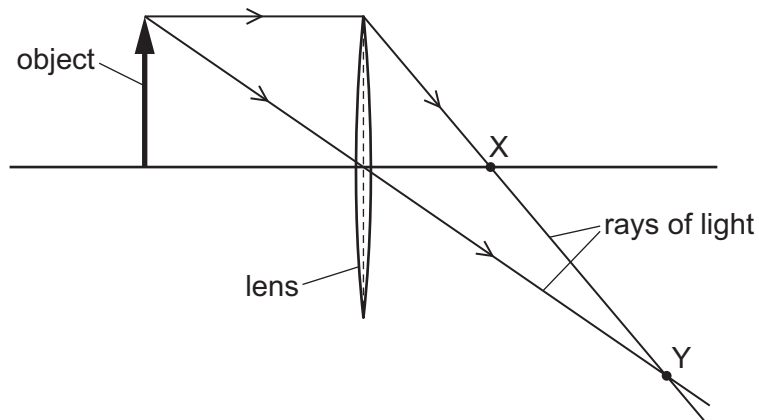

Which labelled point X or Y is a principal focus of the lens, and how does the size of the image compare with the size of the object?

	principal focus	size of image
A	X	larger than object
B	X	smaller than object
C	Y	larger than object
D	Y	smaller than object

- 35 What is the approximate range of frequencies of sound that can be heard by humans?

- A** 2.0 Hz to 200 Hz
- B** 2.0 Hz to 20 000 Hz
- C** 20 Hz to 20 000 Hz
- D** 2000 Hz to 20 000 Hz

36 Which diagram shows the pattern of the magnetic field lines around a bar magnet?

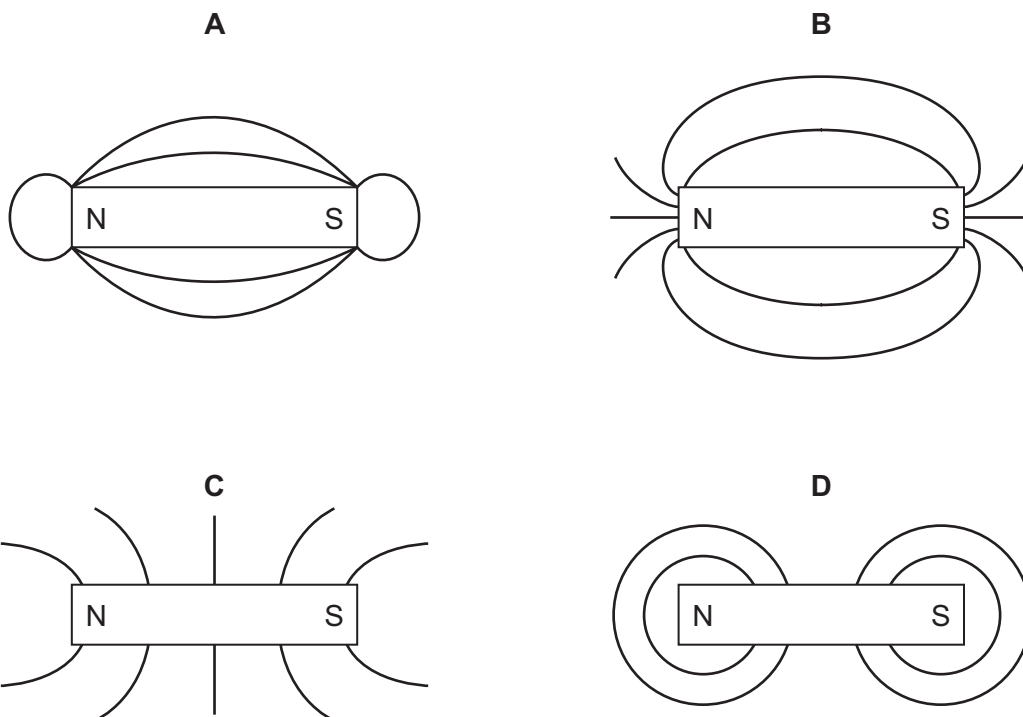

37 A circuit contains a lamp and a fuse.

There is a current of 2.0 A in the lamp and it operates normally.

A fault develops in the lamp. The current in the circuit increases, and the fuse now blows.

The diagrams show two circuits.

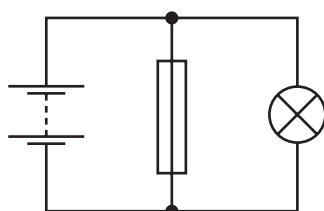

diagram 1

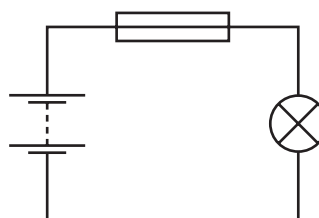

diagram 2

Which is the circuit used and what is the effect of the fuse when it blows?

	circuit	effect of fuse
A	diagram 1	reduces current to 0
B	diagram 1	reduces current to 2.0 A
C	diagram 2	reduces current to 0
D	diagram 2	reduces current to 2.0 A

- 38 Two resistors with resistances $1.0\ \Omega$ and $2.0\ \Omega$ are connected in parallel.

What is their combined resistance?

- A less than $1.0\ \Omega$
 - B between $1.0\ \Omega$ and $2.0\ \Omega$
 - C between $2.0\ \Omega$ and $3.0\ \Omega$
 - D $3.0\ \Omega$
- 39 There is a current in a wire at right angles to a magnetic field. This causes the wire to move upwards.

Both the current and magnetic field directions are reversed.

In which direction does the wire now move?

- A downwards
 - B to the left
 - C to the right
 - D upwards
- 40 The atomic number of an isotope is 6 and the mass number is 14.

How many neutrons and how many protons are in the nucleus of an atom of this isotope?

	neutrons	protons
A	8	6
B	8	8
C	14	6
D	14	8

Permission to reproduce items where third-party owned material protected by copyright is included has been sought and cleared where possible. Every reasonable effort has been made by the publisher (UCLES) to trace copyright holders, but if any items requiring clearance have unwittingly been included, the publisher will be pleased to make amends at the earliest possible opportunity.

To avoid the issue of disclosure of answer-related information to candidates, all copyright acknowledgements are reproduced online in the Cambridge International Examinations Copyright Acknowledgements Booklet. This is produced for each series of examinations and is freely available to download at www.cie.org.uk after the live examination series.

Cambridge International Examinations is part of the Cambridge Assessment Group. Cambridge Assessment is the brand name of University of Cambridge Local Examinations Syndicate (UCLES), which is itself a department of the University of Cambridge.

The Periodic Table of Elements

Group																		
I	II											III	IV	V	VI	VII	VIII	
3 Li lithium 7	4 Be beryllium 9	<div style="border: 1px solid black; padding: 5px; text-align: center;"> Key atomic number atomic symbol name relative atomic mass </div>										5 B boron 11	6 C carbon 12	7 N nitrogen 14	8 O oxygen 16	9 F fluorine 19	10 Ne neon 20	
11 Na sodium 23	12 Mg magnesium 24											1 H hydrogen 1	13 Al aluminium 27	14 Si silicon 28	15 P phosphorus 31	16 S sulfur 32	17 Cl chlorine 35.5	18 Ar argon 40
19 K potassium 39	20 Ca calcium 40	21 Sc scandium 45	22 Ti titanium 48	23 V vanadium 51	24 Cr chromium 52	25 Mn manganese 55	26 Fe iron 56	27 Co cobalt 59	28 Ni nickel 59	29 Cu copper 64	30 Zn zinc 65	31 Ga gallium 70	32 Ge germanium 73	33 As arsenic 75	34 Se selenium 79	35 Br bromine 80	36 Kr krypton 84	
37 Rb rubidium 85	38 Sr strontium 88	39 Y yttrium 89	40 Zr zirconium 91	41 Nb niobium 93	42 Mo molybdenum 96	43 Tc technetium —	44 Ru ruthenium 101	45 Rh rhodium 103	46 Pd palladium 106	47 Ag silver 108	48 Cd cadmium 112	49 In indium 115	50 Sn tin 119	51 Sb antimony 122	52 Te tellurium 128	53 I iodine 127	54 Xe xenon 131	
55 Cs caesium 133	56 Ba barium 137	57–71 lanthanoids	72 Hf hafnium 178	73 Ta tantalum 181	74 W tungsten 184	75 Re rhenium 186	76 Os osmium 190	77 Ir iridium 192	78 Pt platinum 195	79 Au gold 197	80 Hg mercury 201	81 Tl thallium 204	82 Pb lead 207	83 Bi bismuth 209	84 Po polonium —	85 At astatine —	86 Rn radon —	
87 Fr francium —	88 Ra radium —	89–103 actinoids	104 Rf rutherfordium —	105 Db dubnium —	106 Sg seaborgium —	107 Bh bohrium —	108 Hs hassium —	109 Mt meitnerium —	110 Ds darmstadtium —	111 Rg roentgenium —	112 Cn copernicium —	114 Fl flerovium —	116 Lv livermorium —	—	—	—	—	—

lanthanoids	57 La lanthanum 139	58 Ce cerium 140	59 Pr praseodymium 141	60 Nd neodymium 144	61 Pm promethium —	62 Sm samarium 150	63 Eu europium 152	64 Gd gadolinium 157	65 Tb terbium 159	66 Dy dysprosium 163	67 Ho holmium 165	68 Er erbium 167	69 Tm thulium 169	70 Yb ytterbium 173	71 Lu lutetium 175
actinoids	89 Ac actinium —	90 Th thorium 232	91 Pa protactinium 231	92 U uranium 238	93 Np neptunium —	94 Pu plutonium —	95 Am americium —	96 Cm curium —	97 Bk berkelium —	98 Cf californium —	99 Es einsteinium —	100 Fm fermium —	101 Md mendelevium —	102 No nobelium —	103 Lr lawrencium —

The volume of one mole of any gas is 24 dm³ at room temperature and pressure (r.t.p.).