



UNIVERSITY OF CAMBRIDGE INTERNATIONAL EXAMINATIONS
International General Certificate of Secondary Education

CO-ORDINATED SCIENCES

0654/11

Paper 1 Multiple Choice

May/June 2012

45 minutes

Additional Materials: Multiple Choice Answer Sheet
 Soft clean eraser
 Soft pencil (type B or HB is recommended)

* 4 3 8 6 2 5 7 4 2 4 *

READ THESE INSTRUCTIONS FIRST

Write in soft pencil.

Do not use staples, paper clips, highlighters, glue or correction fluid.

Write your name, Centre number and candidate number on the Answer Sheet in the spaces provided unless this has been done for you.

There are **forty** questions on this paper. Answer **all** questions. For each question there are four possible answers **A, B, C** and **D**.

Choose the **one** you consider correct and record your choice in **soft pencil** on the separate Answer Sheet.

Read the instructions on the Answer Sheet very carefully.

Each correct answer will score one mark. A mark will not be deducted for a wrong answer.

Any rough working should be done in this booklet.

A copy of the Periodic Table is printed on page 20.

This document consists of **17** printed pages and **3** blank pages.



1 The diagram shows a section through a cell from a leaf.

Which part is the cell membrane?

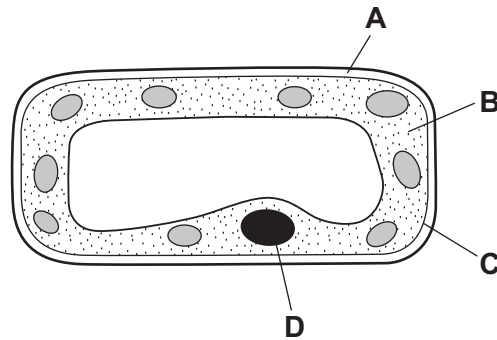

2 What happens in photosynthesis?

- A Carbon dioxide is made.
- B Oxygen is used.
- C Starch is absorbed.
- D Water is used.

3 Which word equation represents aerobic respiration?

- A carbon dioxide + oxygen → glucose + water
- B carbon dioxide + water → glucose + oxygen
- C glucose + oxygen → carbon dioxide + water
- D glucose + oxygen → lactic acid

4 Some cancer treatments cause a reduction in the number of a person's white blood cells.

Why might this be a problem?

- A Blood takes longer to clot.
- B Infections are more likely to cause illness.
- C Insufficient oxygen reaches the brain.
- D Less carbon dioxide is carried to the lungs.

5 Why is calcium needed in the diet?

- A to make carbohydrates
- B to make teeth
- C to make enzymes
- D to make muscles hard

- 6 The diagram shows part of the alimentary canal.

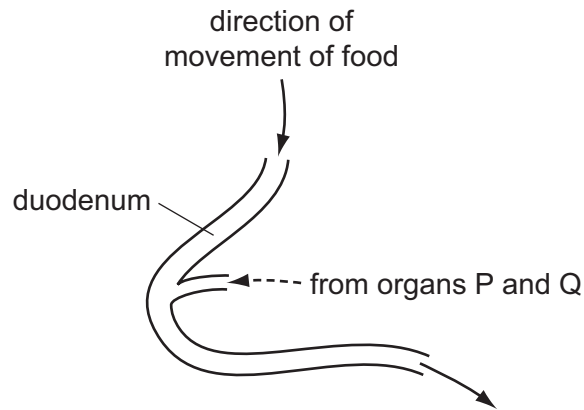

Which organs are represented by P and Q?

- A kidneys and pancreas
 - B liver and pancreas
 - C liver and stomach
 - D pancreas and stomach
- 7 A person touches a hot object which triggers a reflex action.
In which order does the signal travel in the reflex arc?
- A relay neurone → spinal cord → sensory neurone
 - B sensory neurone → spinal cord → motor neurone
 - C spinal cord → sensory neurone → stimulus
 - D stimulus → motor neurone → spinal cord
- 8 The graph shows body temperature before, during and after running a race on a hot day.

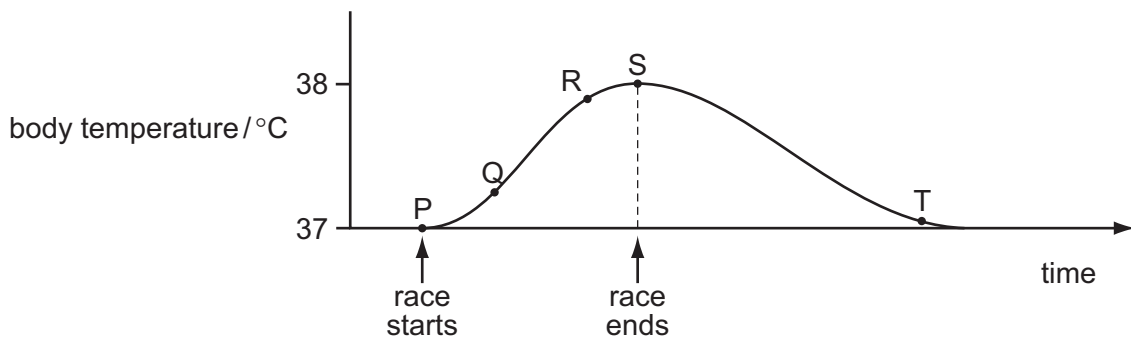

Which change in body temperature occurs as a result of homeostasis?

- A P to Q
- B Q to R
- C R to S
- D S to T

- 9 Which structure contracts to expel the baby during birth?
- A cervix
B oviduct
C uterus wall
D vagina
- 10 In a flowering plant, which structure contains the female gamete?
- A anther
B ovule
C pollen grain
D stigma
- 11 The diagram shows the results of a breeding experiment using black and white mice.

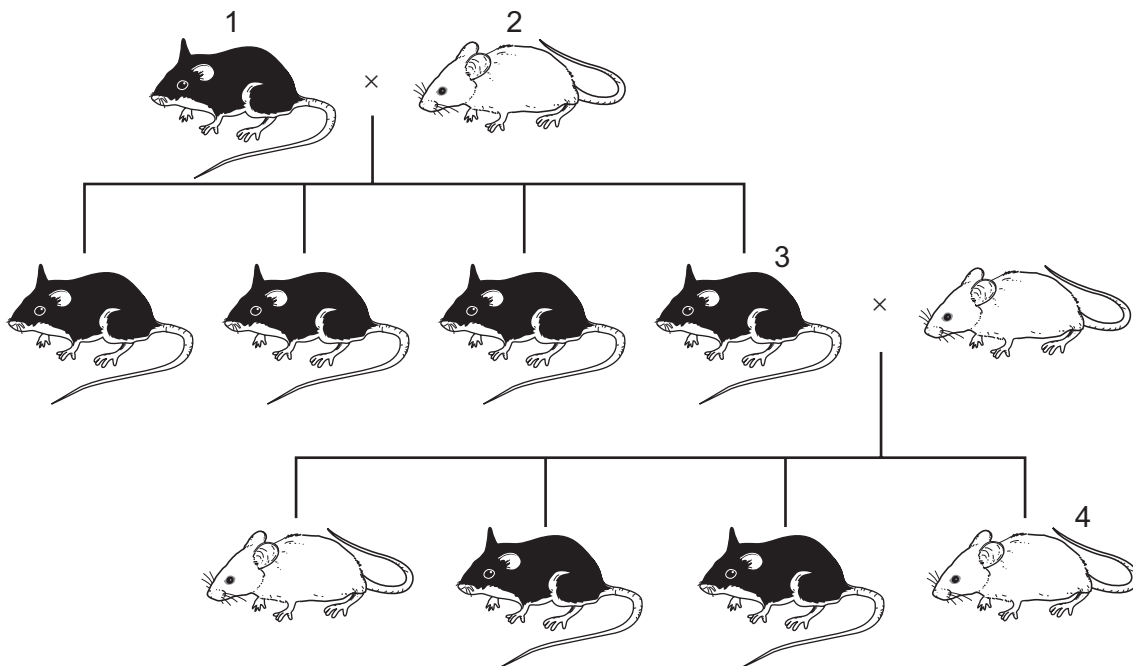

Which statement is correct?

- A Mouse 1 has a dominant allele for fur colour.
B Mouse 2 is heterozygous for fur colour.
C Mouse 3 is homozygous for fur colour.
D Mouse 4 is heterozygous for fur colour.

12 The diagram shows a food chain.

Which organisms pass the greatest amount of energy along the food chain?



13 What can lead to global warming?

	deforestation	burning of fossil fuels
A	✓	✓
B	✓	x
C	x	✓
D	x	x

14 The colours in an ink can be separated by chromatography.

Which diagram shows the correct way to set up the apparatus?

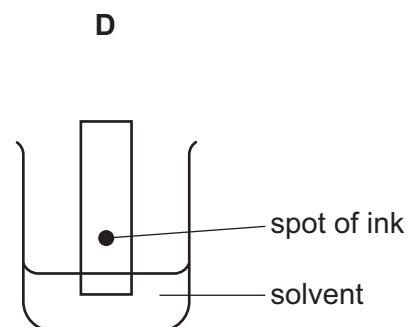
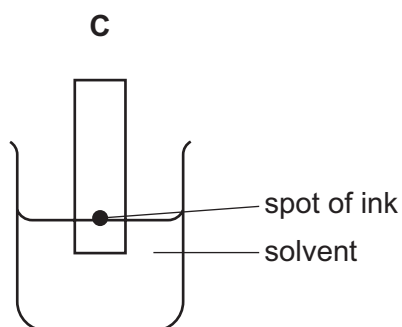
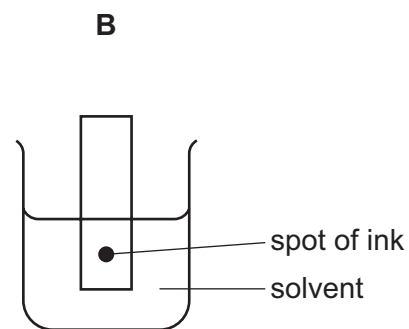
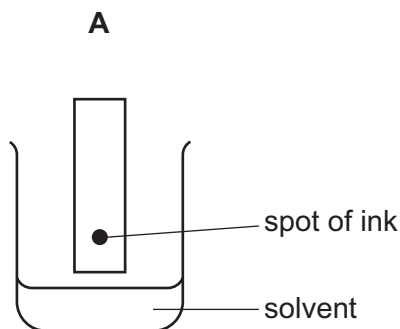

15 The diagram shows a helium atom.

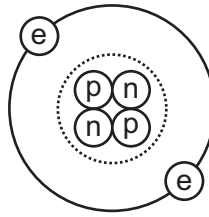

Which particles in the helium atom have approximately the same mass?

- A electron and proton only
- B electron and neutron only
- C proton and neutron only
- D electron, proton and neutron

16 How many atoms of metals and of non-metals are shown in the formula Na_2SO_4 ?

	atoms of metals	atoms of non-metals
A	1	1
B	1	2
C	2	4
D	2	5

- 17 The apparatus shown is used to investigate the speed of reaction between hydrochloric acid and calcium carbonate.

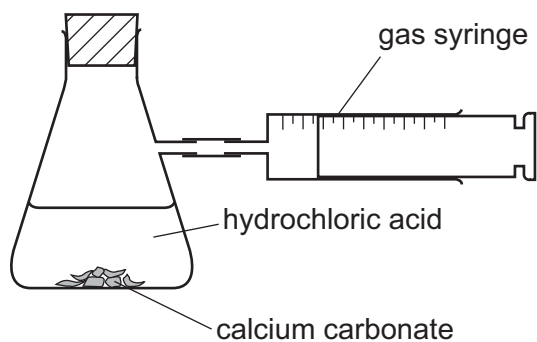

The time to collect 50 cm^3 of gas is measured.

Using concentrated acid and lumps of calcium carbonate, the time is 150 s.

In a second experiment, the time is 90 s.

Which change was made in the second experiment?

- A larger lumps of calcium carbonate
 - B less concentrated acid
 - C lower temperature
 - D powdered calcium carbonate
- 18 Hydrogen and oxygen react explosively to form water.

Which terms describe this reaction?

	combustion	oxidation
A	✓	✓
B	✓	x
C	x	✓
D	x	x

- 19 The diagram shows litmus paper testing the gas that is given off from the contents of the test tube.

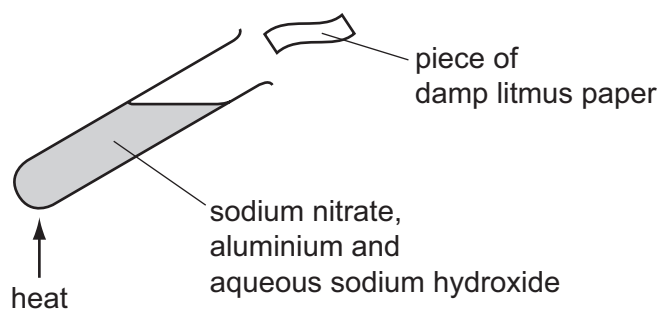

The damp litmus paper

- A turns blue.
 - B turns colourless.
 - C turns red.
 - D turns red then colourless.
- 20 Universal Indicator solution is added to test-tubes W, X and Y.

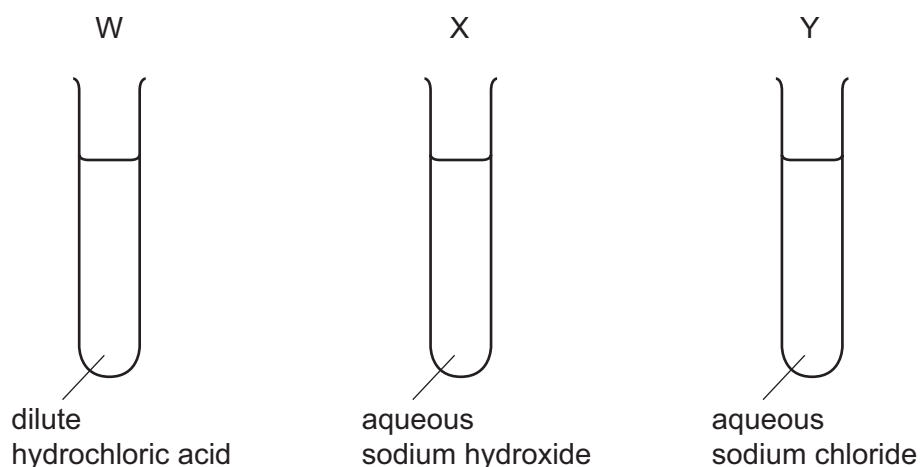

What are the colours of the Universal Indicator?

	in W	in X	in Y
A	green	red	purple
B	purple	green	red
C	red	green	purple
D	red	purple	green

21 The table shows physical properties of some substances.

Which substance is a metal?

	malleability	density	electrical conductivity
A	brittle	high density	high
B	brittle	low density	low
C	malleable	high density	high
D	malleable	low density	low

22 Which statement about lithium, sodium and potassium is **not** correct?

- A** They are in the same group of the Periodic Table.
- B** They are in the same period of the Periodic Table.
- C** They float on water.
- D** They react with water to give a flammable gas.

23 Copper is obtained from copper oxide by heating with non-metal X.

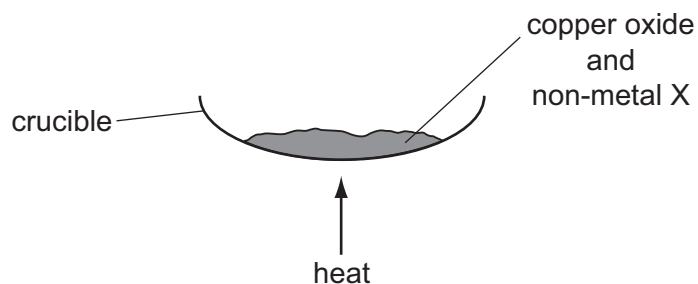

Which shows the identity of non-metal X and the type of reaction non-metal X undergoes?

	identity of X	type of reaction
A	carbon	oxidation
B	carbon	reduction
C	oxygen	oxidation
D	oxygen	reduction

24 In which tube does the iron nail rust in the shortest time?

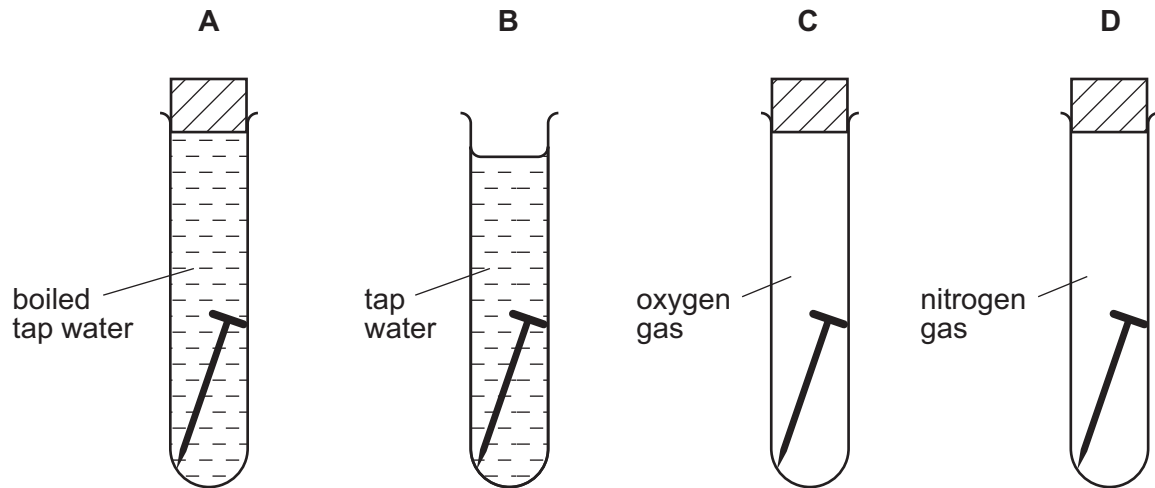

25 Fertilisers are used to supply the essential elements needed for plant growth.

Which compound supplies two of these essential elements?

- A $\text{Ca}(\text{H}_2\text{PO}_4)_2$
- B $\text{Ca}(\text{NO}_3)_2$
- C KNO_3
- D $(\text{NH}_4)_2\text{SO}_4$

26 The burning of a fuel is investigated using the apparatus shown.

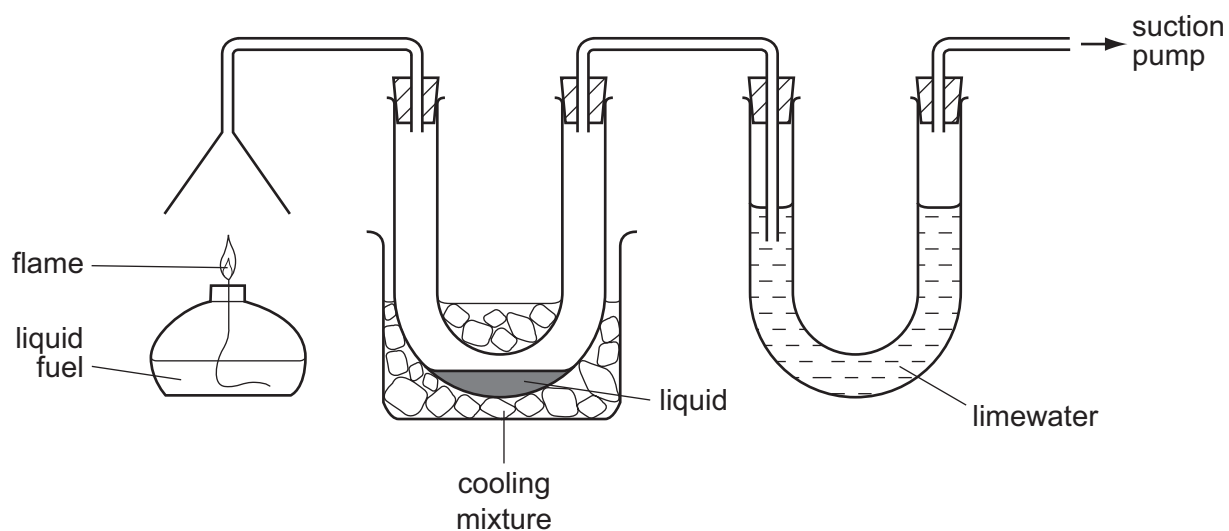

Which substances is the apparatus testing for?

- A carbon monoxide and carbon dioxide
- B carbon monoxide and water
- C carbon dioxide and water
- D carbon dioxide and sulfur dioxide

27 The diagram shows three molecules.

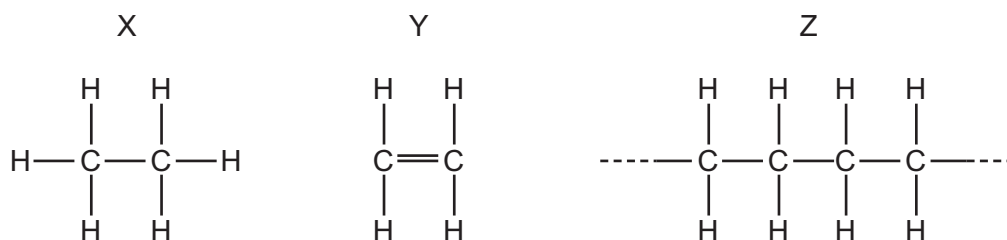

Which molecule is a monomer and which is a polymer?

	monomer	polymer
A	X	Z
B	Y	Z
C	Y	X
D	Z	Y

- 28 A motorist starts out on a 210 km journey at 8 am. At 10 am he stops for a 30 minute break after covering 180 km. The motorist completes the journey at 11 am.

What is his average speed in covering the 210 km?

- A 60 km/h B 70 km/h C 84 km/h D 90 km/h

- 29 The diagrams show a glass tank with inside measurements of 5 cm × 6 cm × 4 cm.

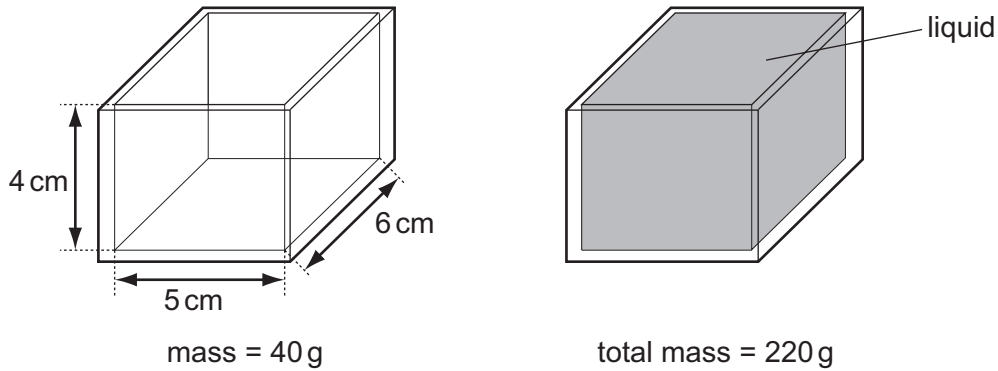

The tank has a mass of 40 g when empty. When the tank is filled with a liquid, the tank and liquid have a total mass of 220 g.

What is the density of the liquid?

- A $\frac{220}{(5 \times 6 \times 4)} \text{ g/cm}^3$
 B $\frac{(220 - 40)}{(5 \times 6 \times 4)} \text{ g/cm}^3$
 C $\frac{(5 \times 6 \times 4)}{220} \text{ g/cm}^3$
 D $\frac{(5 \times 6 \times 4)}{(220 - 40)} \text{ g/cm}^3$

- 30 A workman lifts a cubic block from ground level to a high shelf using a fork lift truck. A second workman has a metre rule and a stopwatch.

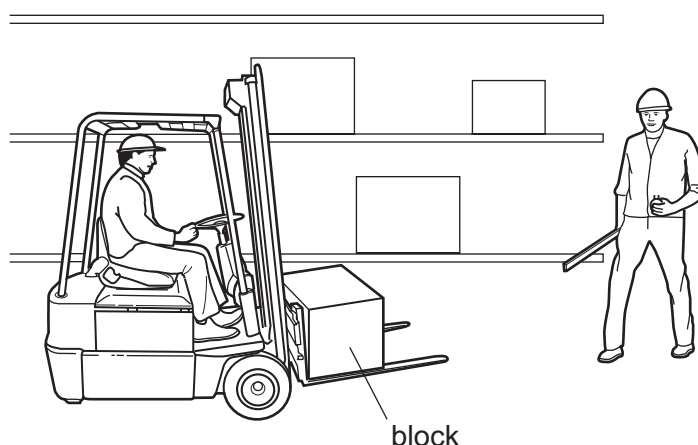

Which quantity will the second workman be able to determine, using **only** the metre rule and the stopwatch?

- A the average speed of the block as it moves up
 - B the density of the material of the block
 - C the pressure exerted by the block on the shelf
 - D the work done on the block when it is lifted
- 31 On a warm day, a driver checks the air pressure in a car tyre. Overnight the temperature drops and the air pressure in the tyre falls. There are no air leaks in the tyre.

Why does the pressure fall?

- A The air molecules in the tyre move more slowly.
 - B The air molecules in the tyre stop moving.
 - C The volume of the air in the tyre decreases.
 - D The volume of the air in the tyre increases.
- 32 How is heat transferred in a vacuum?
- A by conduction and convection
 - B by convection and radiation
 - C by convection only
 - D by radiation only

33 The diagram shows water waves travelling towards a barrier.

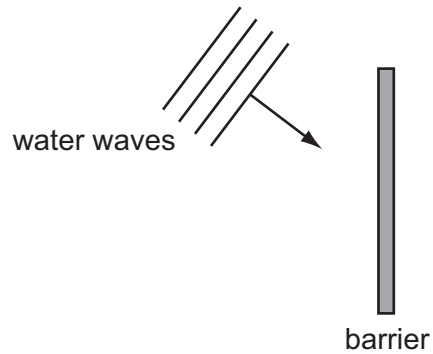

Which diagram shows the direction of the waves after being reflected by the barrier?

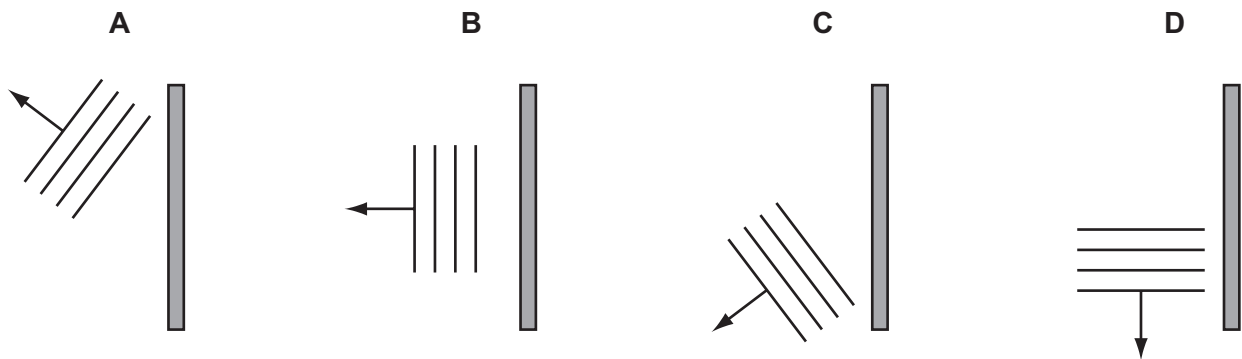

34 A glass block is surrounded by a vacuum. A ray of light strikes the inside of the glass block, and is totally reflected back into the block.

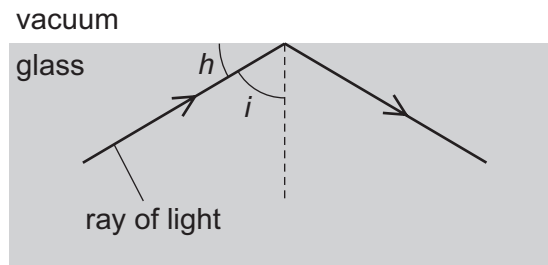

Why does this happen?

- A Angle h is greater than the critical angle.
- B Angle i is greater than the critical angle.
- C Light cannot travel through a vacuum.
- D The ray is travelling along the normal.

35 The Sun emits infra-red radiation, ultraviolet radiation and visible light.

Which statement about the time it takes these radiations to reach Earth's atmosphere is correct?

- A Infra-red radiation arrives first.
- B Ultraviolet radiation arrives first.
- C Visible light arrives first.
- D They all arrive at the same time.

36 Astronaut 1 uses a hammer to mend a satellite in space. Astronaut 2 is nearby. There is no air in space.

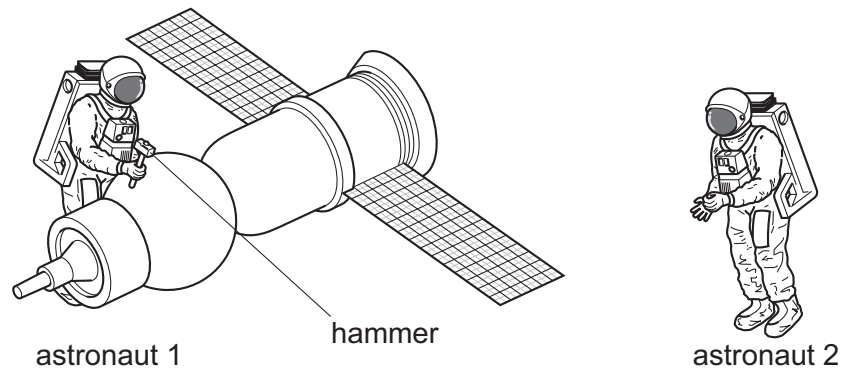

Compared with the sound heard if they were working on Earth, what does astronaut 2 hear?

- A a louder sound
- B a quieter sound
- C a sound of the same loudness
- D no sound at all

37 The instructions for a household lamp state that the plug should be fitted with a 3 A fuse.

What could happen if, by mistake, a 13 A fuse is fitted?

- A The fuse might melt too easily.
- B The lamp might explode if a fault develops.
- C The wires connecting the lamp to the plug might overheat if a fault developed.
- D Too much voltage might be supplied to the lamp.

- 38 A $3.0\ \Omega$ resistor and a $6.0\ \Omega$ resistor are connected to a power supply as shown.

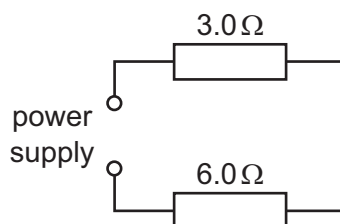

What is the total resistance of the circuit?

- A** $2.0\ \Omega$ **B** $3.0\ \Omega$ **C** $9.0\ \Omega$ **D** $18\ \Omega$
- 39 In the lighting circuit in a house, how are lamps usually connected, and what is one reason for this?

	usual connection	reason
A	parallel	to allow every lamp to have the full supply voltage
B	parallel	to share out the voltage equally between the lamps
C	series	to allow every lamp to have the full supply voltage
D	series	to share out the voltage equally between the lamps

- 40 What are carbon-12 and carbon-14?
- A** atoms of different elements with different nuclear masses
- B** atoms of different elements with the same nuclear mass
- C** atoms of the same element with different nuclear masses
- D** atoms of the same element with the same nuclear mass

DATA SHEET
The Periodic Table of the Elements

		Group										
		I	II	III	IV	V	VI	VII	VIII	IX	X	
		1 H Hydrogen 1										
		4 He Helium 2										
7	9	3	4	5	6	7	8	9	10	11	12	13
Li Lithium	Be Beryllium	B Boron	C Carbon	N Nitrogen	O Oxygen	F Fluorine	Ne Neon	Na Sodium	Mg Magnesium	Al Aluminium	Si Silicon	P Phosphorus
11	12	13	14	15	16	17	18	19	20	21	22	23
Na Sodium	Mg Magnesium	Al Aluminium	Si Silicon	P Phosphorus	S Sulfur	Cl Chlorine	Ar Argon	K Potassium	Ca Calcium	Sc Scandium	Ti Titanium	V Vanadium
19	20	21	22	23	24	25	26	27	28	29	30	31
K Potassium	Ca Calcium	Sc Scandium	Ti Titanium	V Vanadium	Cr Chromium	Mn Manganese	Fe Iron	Co Cobalt	Ni Nickel	Cu Copper	Zn Zinc	Ga Gallium
37	38	39	40	41	42	43	44	45	46	47	48	49
Rb Rubidium	Sr Strontium	Y Yttrium	Zr Zirconium	Nb Niobium	Mo Molybdenum	Tc Technetium	Ru Ruthenium	Rh Rhodium	Pd Palladium	Ag Silver	Cd Cadmium	In Indium
55	56	57	72	73	74	75	76	77	78	79	80	81
Cs Caesium	Ba Barium	La Lanthanum	Hf Hafnium	Ta Tantalum	W Tungsten	Re Rhenium	Os Osmium	Ir Iridium	Pt Platinum	Au Gold	Hg Mercury	Tl Thallium
87	88	89	†	†	†	†	†	†	†	†	†	†
Fr Francium	Ra Radium	Ac Actinium										

		140	141	144	150	152	157	159	162	165	167	169	173	175
		Ce Cerium	Pr Praseodymium	Nd Neodymium	Sm Samarium	Eu Europium	Gd Gadolinium	Tb Terbium	Dy Dysprosium	Ho Holmium	Er Erbium	Tm Thulium	Yb Ytterbium	Lu Lutetium
		58	59	60	62	63	64	65	66	67	68	69	70	71
		Th Thorium	Pa Protactinium	U Uranium	Pu Plutonium	Am Americium	Cm Curium	Bk Berkelium	Cf Californium	Es Einsteinium	Fm Fermium	Md Mendelevium	No Nobelium	Lr Lawrencium
		90	91	92	94	95	96	97	98	99	100	101	102	103

		a		b		X		Y		Z
Key										

*58-71 Lanthanoid series
†90-103 Actinoid series

a = relative atomic mass
X = atomic symbol
b = proton (atomic) number

The volume of one mole of any gas is 24 dm³ at room temperature and pressure (r.t.p.).

Permission to reproduce items where third-party owned material protected by copyright is included has been sought and cleared where possible. Every reasonable effort has been made by the publisher (UCLES) to trace copyright holders, but if any items requiring clearance have unwittingly been included, the publisher will be pleased to make amends at the earliest possible opportunity.

University of Cambridge International Examinations is part of the Cambridge Assessment Group. Cambridge Assessment is the brand name of University of Cambridge Local Examinations Syndicate (UCLES), which is itself a department of the University of Cambridge.