



UNIVERSITY OF CAMBRIDGE INTERNATIONAL EXAMINATIONS
International General Certificate of Secondary Education

CO-ORDINATED SCIENCES

0654/11

Paper 1 Multiple Choice

May/June 2011

45 minutes

Additional Materials: Multiple Choice Answer Sheet
Soft clean eraser
Soft pencil (type B or HB is recommended)

* 3 5 5 1 8 4 8 1 2 9 *

READ THESE INSTRUCTIONS FIRST

Write in soft pencil.

Do not use staples, paper clips, highlighters, glue or correction fluid.

Write your name, Centre number and candidate number on the Answer Sheet in the spaces provided unless this has been done for you.

There are **forty** questions on this paper. Answer **all** questions. For each question there are four possible answers **A, B, C** and **D**.

Choose the **one** you consider correct and record your choice in **soft pencil** on the separate Answer Sheet.

Read the instructions on the Answer Sheet very carefully.

Each correct answer will score one mark. A mark will not be deducted for a wrong answer.

Any rough working should be done in this booklet.

A copy of the Periodic Table is printed on page 16.

This document consists of **15** printed pages and **1** blank page.



1 The diagram shows four vertebrate animals.

P

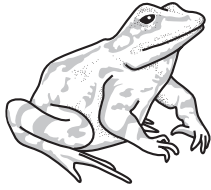

Q

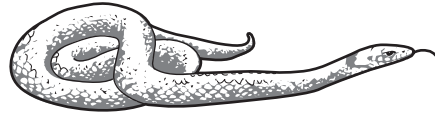

R

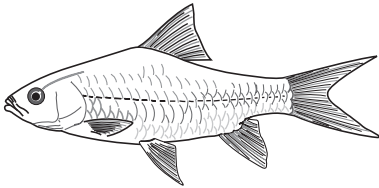

S

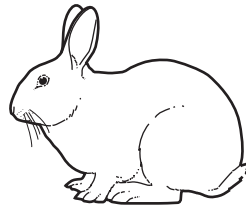

Which animals have lungs?

- A** P, Q and R **B** Q, R and S **C** R, S and P **D** S, P and Q

2 The diagram shows a root hair cell.

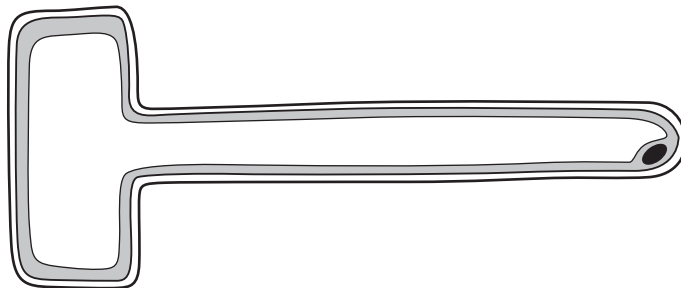

What shows that it is a plant cell?

- A** It has a large surface area.
B It has a large vacuole.
C It has no cell membrane.
D It has no cell wall.

3 Which molecule carries energy into a cell and which is a process that uses this energy?

	molecule	process
A	glucose	growth
B	iron	movement
C	protein	digestion
D	starch	storage

4 The diagram shows a section through the heart.

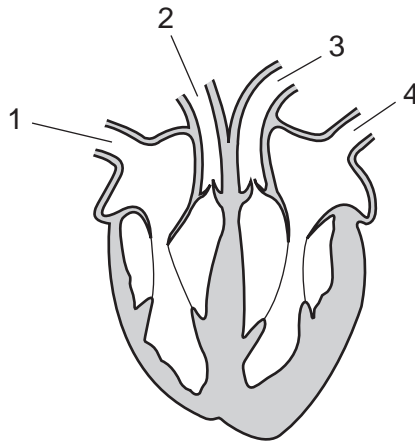

Which two blood vessels are arteries?

- A** 1 and 2 **B** 2 and 3 **C** 3 and 4 **D** 4 and 1

5 Which process releases energy in all living things?

- A** breathing
B digestion
C muscle contraction
D respiration

6 Tests were carried out on a clear liquid. The table shows the results.

test	result
biuret	purple colour
ethanol	white colour
iodine	brown colour

What did the clear liquid contain?

	fat	protein	starch	
A	✓	✓	✓	key ✓ = yes x = no
B	✓	✓	x	
C	✓	x	✓	
D	x	✓	✓	

7 The diagram shows part of the alimentary canal.

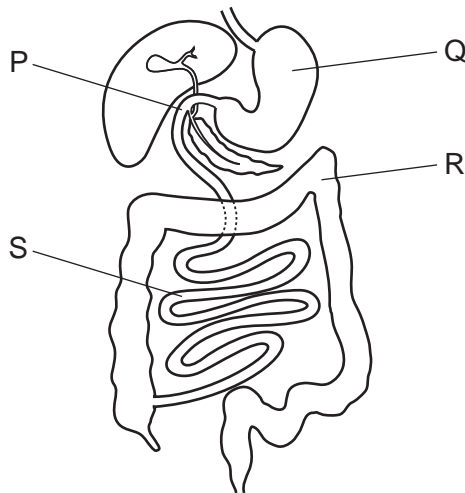

Where is bile added and where is acid released?

	addition of bile	release of acid
A	P	Q
B	Q	R
C	R	S
D	S	P

- 8 What happens shortly after eating a large amount of sugar?
- A More insulin is secreted by the pancreas.
 - B More urea is made in the liver.
 - C More urine is excreted by the kidneys.
 - D More water is removed from the blood.
- 9 What passes from a mother to a fetus in her uterus?
- A blood platelets
 - B mineral ions
 - C plasma
 - D red blood cells
- 10 Why is seed dispersal important?
- A It causes the development of a fruit.
 - B It makes seeds more fertile.
 - C It prevents asexual reproduction.
 - D It reduces competition between seedlings.
- 11 Which is an example of cloning?
- A pollinating flowers by insects
 - B producing offspring by sexual intercourse
 - C producing plants by tissue culture
 - D seeds forming in an ovary
- 12 What is an ecosystem?
- A a community and its habitat
 - B a group of organisms and their predators
 - C all the organisms in a food chain
 - D where an organism lives

13 The diagram shows a short food chain.

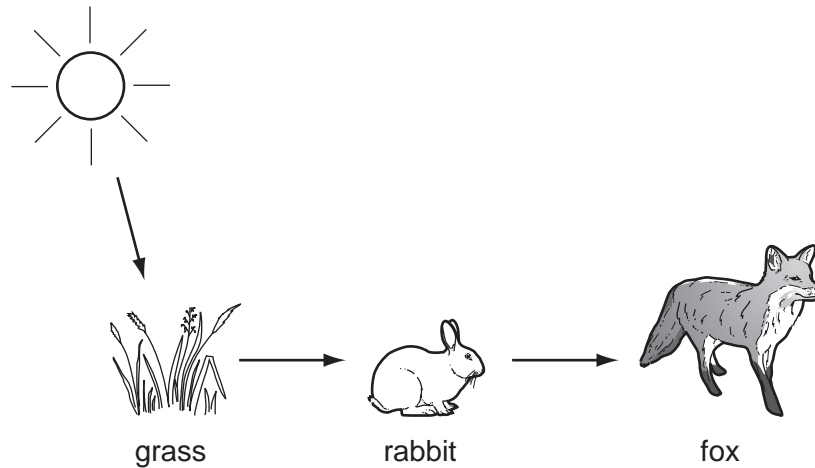

In the food chain, what is the importance of the rabbit?

- A It absorbs carbon dioxide.
- B It absorbs the Sun's energy.
- C It passes on energy from plants.
- D It releases oxygen.

14 The graph shows the changes in temperature when a substance is cooled.

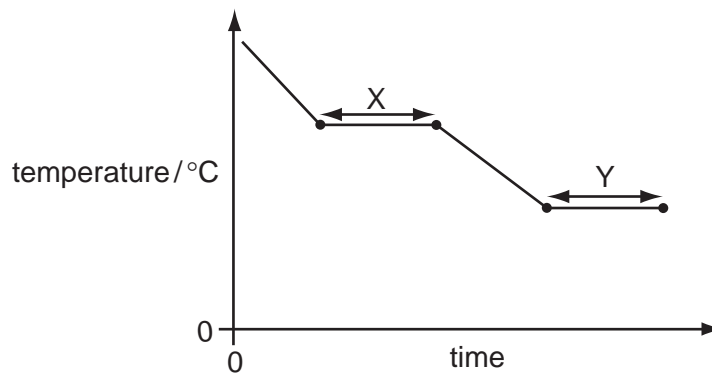

Which describes the processes occurring at X and Y?

	X	Y
A	boiling	melting
B	condensing	freezing
C	freezing	condensing
D	melting	boiling

15 Which trends in physical properties are correct for the alkali metals down Group I?

	hardness	melting point
A	decreases	decreases
B	decreases	increases
C	increases	decreases
D	increases	increases

16 Large hydrocarbons can be1..... to make smaller, more useful molecules.

Small hydrocarbon molecules can be2..... to make long molecules.

Which words correctly complete gaps 1 and 2?

	1	2
A	cracked	distilled
B	cracked	polymerised
C	distilled	polymerised
D	distilled	cracked

17 What is made when amino acids join together in a large chain?

- A** cellulose
- B** glucose
- C** protein
- D** starch

18 Some properties of three substances are shown.

substance	melting point /°C	boiling point /°C	electrical conductivity when molten
W	801	1413	good
X	-111	-78	poor
Y	1610	2230	poor

What are the structures of W, X and Y?

	giant covalent structure	giant ionic structure	molecular structure
A	W	Y	X
B	X	W	Y
C	Y	W	X
D	Y	X	W

19 How is carbon (coke) used in the extraction of iron from iron oxide?

- A** as an anode
- B** as a cathode
- C** as an oxidising agent
- D** as a reducing agent

20 Electrolysis of sodium chloride is used to obtain chlorine.

In what form is sodium chloride electrolysed and at which electrode is the chlorine obtained?

	form of sodium chloride	electrode at which chlorine is obtained
A	in aqueous solution	anode
B	in aqueous solution	cathode
C	solid	anode
D	solid	cathode

21 A solution is tested by adding acidified silver nitrate solution.

Which ion causes the white precipitate to form?

- A chloride ions, Cl^-
- B copper ions, Cu^{2+}
- C hydroxide ions, OH^-
- D sodium ions, Na^+

22 Sodium hydroxide solution is added to hydrochloric acid.

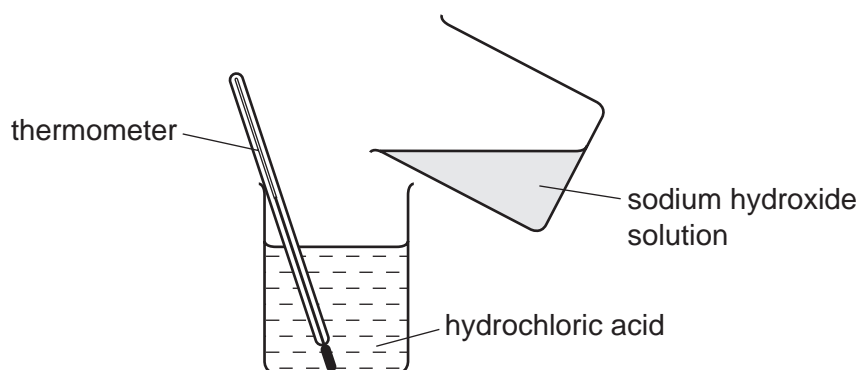

Which shows how the pH and temperature change as the reaction takes place?

	pH	temperature
A	decrease	decrease
B	decrease	increase
C	increase	decrease
D	increase	increase

23 Which statements about a positive test for a nitrate ion are correct?

- 1 Aluminium is used.
- 2 The nitrate ion is reduced to ammonia.
- 3 Ammonia turns damp litmus paper red.

- A** 1, 2 and 3
- B** 1 and 2 only
- C** 1 and 3 only
- D** 2 and 3 only

24 Aspirin can be used to relieve headaches.

Which terms correctly describe aspirin?

	analgesic	chemotherapy agent	drug
A	✓	✓	x
B	✓	x	✓
C	x	✓	x
D	x	x	✓

key

✓ = yes

x = no

25 Which is **not** a colloid?

- A** cellulose
- B** milk
- C** paint
- D** smoke

26 Which statement about methane is **not** correct?

- A** Methane burns in air to form carbon dioxide and water.
- B** Methane can be obtained from the decay of waste material.
- C** Methane is a fossil fuel.
- D** When methane burns, an endothermic reaction takes place.

27 The diagram shows part of the Periodic Table.

Which element has atoms containing three electrons in the outer shell?

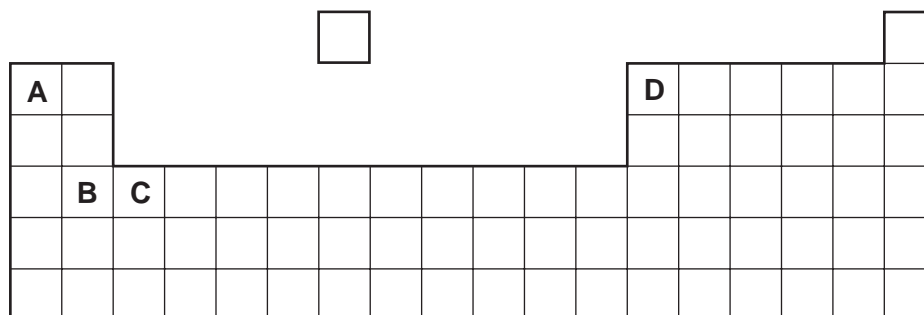

28 A student needs to find the density of a large cubic block of wood.

Which two pieces of apparatus should she use?

- A balance and metre rule
- B balance and thermometer
- C measuring cylinder and metre rule
- D measuring cylinder and thermometer

29 In an experiment, a student measures the time taken for an object to fall to the ground. He carries out the experiment ten times. The table shows his results.

time/s	26.4	26.8	26.4	24.4	24.0	26.8	25.4	23.4	26.4	24.0
--------	------	------	------	------	------	------	------	------	------	------

Which value should the student use?

- A 24.0 s
- B 25.4 s
- C 26.4 s
- D 26.8 s

30 One side of a cube stands on the ground.

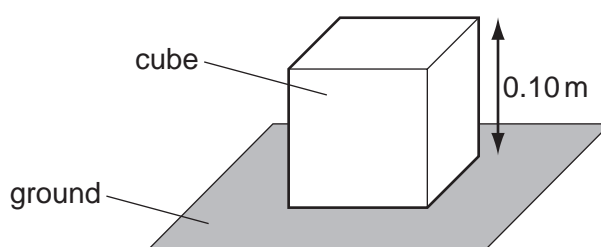

The cube weighs 200 N and its sides are 0.10 m long.

How much pressure does the cube exert on the ground?

- A 2.0 Pa
- B 20 Pa
- C 2000 Pa
- D 20 000 Pa

31 What is meant by the current in a wire?

- A the charge flowing through the wire per second
- B the energy the wire can transfer elsewhere per second
- C the power the wire can produce per second
- D the work the wire does per second

32 Which group contains only secondary colours of light?

- A cyan, green, magenta
- B cyan, green, yellow
- C green, magenta, yellow
- D yellow, cyan, magenta

33 Two cars have different masses and different speeds as shown.

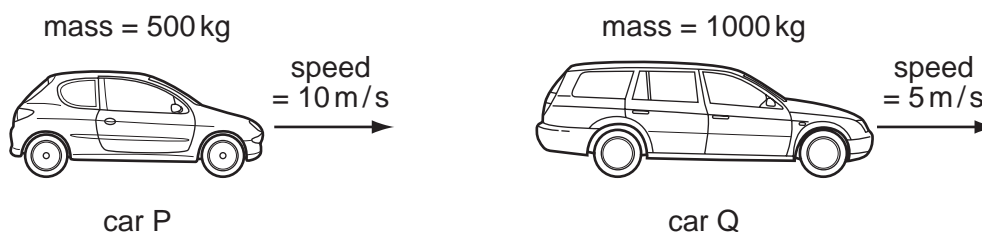

How do the momentum and the kinetic energy of the two cars compare?

	momentum	kinetic energy
A	P greater than Q	P less than Q
B	P equal to Q	P greater than Q
C	P equal to Q	P equal to Q
D	P less than Q	P equal to Q

34 A satellite orbits the Earth.

Is the satellite in a gravitational field and is the satellite in a magnetic field?

	a gravitational field	a magnetic field
A	✓	✓
B	✓	✗
C	✗	✓
D	✗	✗

key

✓ = in field

✗ = not in field

35 Microphones and earphones are both used with audio equipment.

Which energy change takes place in a microphone and which takes place in an earphone?

	microphone	earphone
A	electrical to sound	electrical to sound
B	electrical to sound	sound to electrical
C	sound to electrical	electrical to sound
D	sound to electrical	sound to electrical

36 The diagram shows the basic structure of a cathode-ray tube in an oscilloscope.

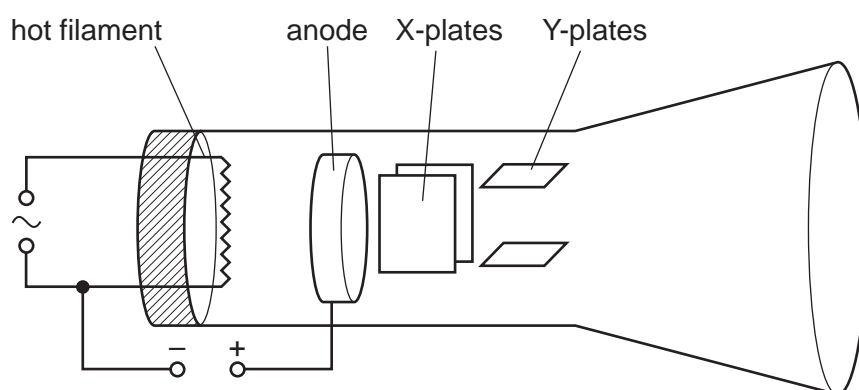

From which component do the cathode rays start?

- A** the anode
- B** the hot filament
- C** the X-plates
- D** the Y-plates

37 Which row describes the properties of beta radiation?

	electromagnetic	ionising	
A	✓	✓	key ✓ = yes x = no
B	✓	x	
C	x	✓	
D	x	x	

- 38 Which process is used in a nuclear power station and which nuclear change happens in this process?

	process used	nuclear change
A	fission	heavy nuclei split
B	fission	light nuclei join together
C	fusion	heavy nuclei split
D	fusion	light nuclei join together

- 39 Electrical energy from a power station is used a long distance away from it.

Which row shows the type of current needed and the device used for efficient transmission?

	type of current	device
A	alternating	dynamo
B	alternating	transformer
C	direct	dynamo
D	direct	transformer

- 40 An electronic circuit is used as a temperature detector.

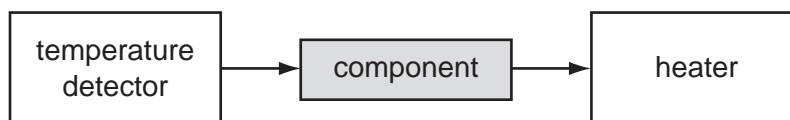

The current in the detector is small. The detector operates a component that allows it to control a larger current in a heater.

Which component is suitable?

- A** a diode
- B** a dynamo
- C** a reed relay
- D** a transformer

DATA SHEET
The Periodic Table of the Elements

		Group										
		II	III	IV	V	VI	VII	0				
		<div style="display: flex; justify-content: space-around;"> 1 H Hydrogen 1 </div>										
		<div style="display: flex; justify-content: space-around;"> 4 He Helium 2 </div>										
<div style="display: flex; justify-content: space-between;"> 7 Li Lithium 3 9 Be Beryllium 4 </div>												<div style="display: flex; justify-content: space-around;"> 19 F Fluorine 9 </div>
<div style="display: flex; justify-content: space-between;"> 11 Na Sodium 11 12 Mg Magnesium 12 </div>												<div style="display: flex; justify-content: space-around;"> 16 O Oxygen 8 </div>
<div style="display: flex; justify-content: space-between;"> 19 K Potassium 19 20 Ca Calcium 20 </div>												<div style="display: flex; justify-content: space-around;"> 34 Se Selenium 34 </div>
<div style="display: flex; justify-content: space-between;"> 37 Rb Rubidium 37 38 Sr Strontium 38 </div>												<div style="display: flex; justify-content: space-around;"> 52 Te Tellurium 52 </div>
<div style="display: flex; justify-content: space-between;"> 55 Cs Caesium 55 56 Ba Barium 56 </div>												<div style="display: flex; justify-content: space-around;"> 84 Po Polonium 84 </div>
<div style="display: flex; justify-content: space-between;"> 87 Fr Francium 87 88 Ra Radium 88 </div>												<div style="display: flex; justify-content: space-around;"> 112 Cd Cadmium 112 </div>
												<div style="display: flex; justify-content: space-around;"> 127 I Iodine 53 </div>
												<div style="display: flex; justify-content: space-around;"> 131 Xe Xenon 54 </div>
												<div style="display: flex; justify-content: space-around;"> 157 Gd Gadolinium 64 </div>
												<div style="display: flex; justify-content: space-around;"> 167 Er Erbium 68 </div>
												<div style="display: flex; justify-content: space-around;"> 173 Yb Ytterbium 70 </div>
												<div style="display: flex; justify-content: space-around;"> 186 Pt Platinum 78 </div>
												<div style="display: flex; justify-content: space-around;"> 201 Hg Mercury 80 </div>
												<div style="display: flex; justify-content: space-around;"> 207 Pb Lead 82 </div>
												<div style="display: flex; justify-content: space-around;"> 209 Bi Bismuth 83 </div>
												<div style="display: flex; justify-content: space-around;"> 210 At Astatine 85 </div>
												<div style="display: flex; justify-content: space-around;"> 226 Ra Radium 88 </div>
												<div style="display: flex; justify-content: space-around;"> 227 Ac Actinium 89 </div>
												<div style="display: flex; justify-content: space-around;"> 238 U Uranium 92 </div>
												<div style="display: flex; justify-content: space-around;"> 238 U Uranium 92 </div>
												<div style="display: flex; justify-content: space-around;"> 232 Th Thorium 90 </div>
												<div style="display: flex; justify-content: space-around;"> 232 Th Thorium 90 </div>
												<div style="display: flex; justify-content: space-around;"> 91 Pa Protactinium 91 </div>
												<div style="display: flex; justify-content: space-around;"> 91 Pa Protactinium 91 </div>
												<div style="display: flex; justify-content: space-around;"> 93 Np Neptunium 93 </div>
												<div style="display: flex; justify-content: space-around;"> 93 Np Neptunium 93 </div>
												<div style="display: flex; justify-content: space-around;"> 94 Pu Plutonium 94 </div>
												<div style="display: flex; justify-content: space-around;"> 94 Pu Plutonium 94 </div>
												<div style="display: flex; justify-content: space-around;"> 95 Am Americium 95 </div>
												<div style="display: flex; justify-content: space-around;"> 95 Am Americium 95 </div>
												<div style="display: flex; justify-content: space-around;"> 96 Cm Curium 96 </div>
												<div style="display: flex; justify-content: space-around;"> 96 Cm Curium 96 </div>
												<div style="display: flex; justify-content: space-around;"> 97 Bk Berkelium 97 </div>
												<div style="display: flex; justify-content: space-around;"> 97 Bk Berkelium 97 </div>
												<div style="display: flex; justify-content: space-around;"> 98 Cf Californium 98 </div>
												<div style="display: flex; justify-content: space-around;"> 98 Cf Californium 98 </div>
												<div style="display: flex; justify-content: space-around;"> 99 Es Einsteinium 99 </div>
												<div style="display: flex; justify-content: space-around;"> 99 Es Einsteinium 99 </div>
												<div style="display: flex; justify-content: space-around;"> 100 Fm Fermium 100 </div>
												<div style="display: flex; justify-content: space-around;"> 100 Fm Fermium 100 </div>
												<div style="display: flex; justify-content: space-around;"> 101 Md Mendelevium 101 </div>
												<div style="display: flex; justify-content: space-around;"> 101 Md Mendelevium 101 </div>
												<div style="display: flex; justify-content: space-around;"> 102 No Nobelium 102 </div>
												<div style="display: flex; justify-content: space-around;"> 102 No Nobelium 102 </div>
												<div style="display: flex; justify-content: space-around;"> 103 Lr Lawrencium 103 </div>
												<div style="display: flex; justify-content: space-around;"> 103 Lr Lawrencium 103 </div>
												<div style="display: flex; justify-content: space-around;"> 104 Rf Rutherfordium 104 </div>
												<div style="display: flex; justify-content: space-around;"> 104 Rf Rutherfordium 104 </div>
												<div style="display: flex; justify-content: space-around;"> 105 Db Dubnium 105 </div>
												<div style="display: flex; justify-content: space-around;"> 105 Db Dubnium 105 </div>
												<div style="display: flex; justify-content: space-around;"> 106 Sg Seaborgium 106 </div>
												<div style="display: flex; justify-content: space-around;"> 106 Sg Seaborgium 106 </div>
												<div style="display: flex; justify-content: space-around;"> 107 Bh Bohrium 107 </div>
												<div style="display: flex; justify-content: space-around;"> 107 Bh Bohrium 107 </div>
												<div style="display: flex; justify-content: space-around;"> 108 Hs Hassium 108 </div>
												<div style="display: flex; justify-content: space-around;"> 108 Hs Hassium 108 </div>
												<div style="display: flex; justify-content: space-around;"> 109 Mt Meitnerium 109 </div>
												<div style="display: flex; justify-content: space-around;"> 109 Mt Meitnerium 109 </div>
												<div style="display: flex; justify-content: space-around;"> 110 Ds Darmstadtium 110 </div>
												<div style="display: flex; justify-content: space-around;"> 110 Ds Darmstadtium 110 </div>
												<div style="display: flex; justify-content: space-around;"> 111 Rg Roentgenium 111 </div>
												<div style="display: flex; justify-content: space-around;"> 111 Rg Roentgenium 111 </div>
												<div style="display: flex; justify-content: space-around;"> 112 Cd Cadmium 112 </div>
												<div style="display: flex; justify-content: space-around;"> 112 Cd Cadmium 112 </div>
												<div style="display: flex; justify-content: space-around;"> 113 Nh Nihonium 113 </div>
												<div style="display: flex; justify-content: space-around;"> 113 Nh Nihonium 113 </div>
												<div style="display: flex; justify-content: space-around;"> 114 Fl Flerovium 114 </div>
												<div style="display: flex; justify-content: space-around;"> 114 Fl Flerovium 114 </div>
												<div style="display: flex; justify-content: space-around;"> 115 Mc Moscovium 115 </div>
												<div style="display: flex; justify-content: space-around;"> 115 Mc Moscovium 115 </div>
												<div style="display: flex; justify-content: space-around;"> 116 Lv Livermorium 116 </div>
												<div style="display: flex; justify-content: space-around;"> 116 Lv Livermorium 116 </div>
												<div style="display: flex; justify-content: space-around;"> 117 Ts Tennessine 117 </div>
												<div style="display: flex; justify-content: space-around;"> 117 Ts Tennessine 117 </div>
												<div style="display: flex; justify-content: space-around;"> 118 Og Oganesson 118 </div>
												<div style="display: flex; justify-content: space-around;"> 118 Og Oganesson 118 </div>

The volume of one mole of any gas is 24 dm³ at room temperature and pressure (r.t.p.).

*58-71 Lanthanoid series
†90-103 Actinoid series

Key
a X b
 a = relative atomic mass
 X = atomic symbol
 b = proton (atomic) number

Permission to reproduce items where third-party owned material protected by copyright is included has been sought and cleared where possible. Every reasonable effort has been made by the publisher (UCLES) to trace copyright holders, but if any items requiring clearance have unwittingly been included, the publisher will be pleased to make amends at the earliest possible opportunity.