



UNIVERSITY OF CAMBRIDGE INTERNATIONAL EXAMINATIONS  
International General Certificate of Secondary Education

CANDIDATE  
NAME

CENTRE  
NUMBER

--	--	--	--	--

CANDIDATE  
NUMBER

--	--	--	--	--

\* 9 2 0 3 1 8 0 5 1 8 \*

**CO-ORDINATED SCIENCES**

**0654/02**

Paper 2 (Core)

**October/November 2008**

**2 hours**

Candidates answer on the Question Paper.

No Additional Materials are required.

**READ THESE INSTRUCTIONS FIRST**

Write your Centre number, candidate number and name on all the work you hand in.

Write in dark blue or black pen.

You may use a soft pencil for any diagrams, graphs, tables or rough working.

Do not use staples, paper clips, highlighters, glue or correction fluid.

**DO NOT WRITE IN ANY BARCODES**

Answer **all** questions.

A copy of the Periodic Table is printed on page 28.

At the end of the examination, fasten all your work securely together.

The number of marks is given in brackets [ ] at the end of each question or part question.

For Examiner's Use	
1	
2	
3	
4	
5	
6	
7	
8	
9	
10	
11	
<b>Total</b>	

This document consists of **25** printed pages and **3** blank pages.



1 A football match is taking place.

(a) When the ball is kicked it travels at 5 m/s.

(i) The ball has a mass of 0.6 kg.

Calculate the kinetic energy of the ball.

State the formula that you use and show your working.

formula

working

..... J [2]

(ii) Calculate the momentum of the ball.

State the formula that you use and show your working.

formula

working

..... kg m/s [2]

(b) Towards the end of the ball's journey it is slowing down.

Are the forces on the ball balanced or unbalanced?

Explain your answer.

.....  
..... [1]

(c) The players need a lot of energy to play a game of football.

State the **two** main food types which supply the players with this energy.

1 .....

2 .....

[2]

- 2 In the 1930s, farmers growing sugar cane in tropical parts of Australia had problems with insect pests, such as lacebugs, that ate the crop. Cane toads, *Bufo marinus*, were introduced from central America to try to solve the problem. Cane toads kill and eat insects and other small animals.

Fig. 2.1 shows a cane toad.

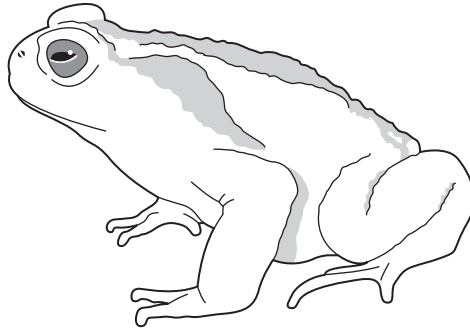

**Fig. 2.1**

- (a) State **one** feature of a cane toad, visible in Fig. 2.1, which shows that it is an amphibian.

..... [1]

- (b) Name the genus to which cane toads belong.

..... [1]

- (c) Use the information above to write a food chain involving cane toads. For each organism, state whether it is a producer or a consumer.

..... [2]

- (d) Biologists noticed that some cane toads had longer legs than others. They thought that perhaps toads with longer legs could travel faster than other toads.

For  
Examiner's  
Use

They collected toads with different leg lengths, and measured the distance the toads travelled in 24 hours. The results are shown in Fig. 2.2.

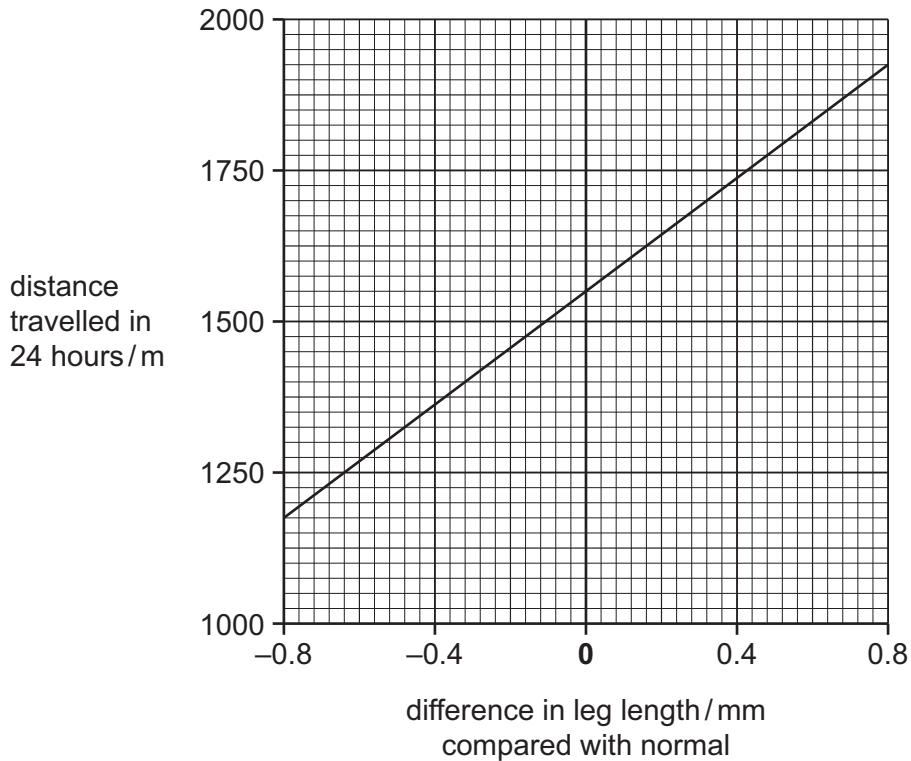

Fig. 2.2

- (i) The number 0 on the x axis indicates toads that had normal leg lengths.

Calculate the speed at which a toad with normal leg length travelled. Show your working.

..... m per hour [2]

- (ii) Describe the relationship between the length of the toad's legs and the speed at which it travelled.

.....  
..... [1]

- (iii) State **two** variables that the researchers should have kept the same in their investigation.

1 .....  
2 ..... [2]

(e) The digestive system of a cane toad is very similar to the human digestive system. The diet of a cane toad is high in protein.

*For  
Examiner's  
Use*

(i) Name the kind of enzyme that digests proteins to amino acids.

..... [1]

(ii) Suggest the part of a cane toad's digestive system where the amino acids are absorbed into the blood.

..... [1]

- 3 A student investigates the reaction between magnesium and dilute acid Y. Fig. 3.1 shows the metal being added to the acid contained in a test-tube, and also the same tube some time later.

For  
Examiner's  
Use

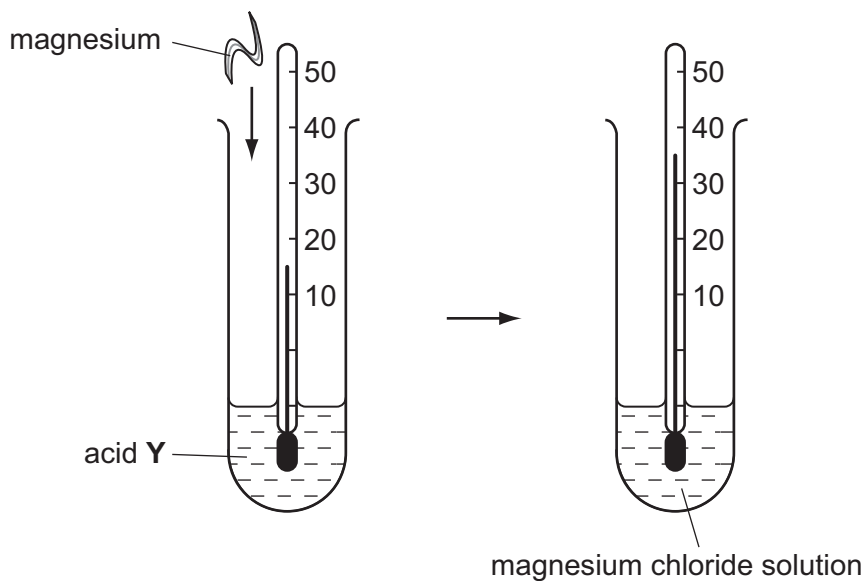

Fig. 3.1

- (a) (i) Name the compound present after the reaction that was not present before.

..... [1]

- (ii) Name acid Y.

..... [1]

- (iii) The student observed bubbles of gas escaping from the mixture. She collected samples of this gas and tested them with limewater, a glowing wooden splint and a lit wooden splint.

Explain which **one** of these tests produced a positive result.

.....  
 .....  
 ..... [2]

- (iv) Explain how it is possible to tell from Fig. 3.1 that the reaction was exothermic.

.....  
 ..... [2]

(b) Magnesium alloys are widely used in making parts for aircraft and racing car engines.

*For  
Examiner's  
Use*

(i) One type of magnesium alloy contains the elements zinc and zirconium.

Suggest how this magnesium alloy is made.

.....  
..... [1]

(ii) Suggest and explain why a magnesium alloy, rather than a transition metal such as iron, is used to make parts for aircraft and racing cars.

.....  
.....  
..... [2]

4 (a) Some countries use nuclear fission reactors to generate electricity.

(i) What is meant by the term *nuclear fission*?

.....  
..... [2]

(ii) State **one** advantage and **one** disadvantage of generating electricity using nuclear reactors.

advantage .....

disadvantage .....

(iii) Complete the boxes to show how nuclear power stations transfer energy.

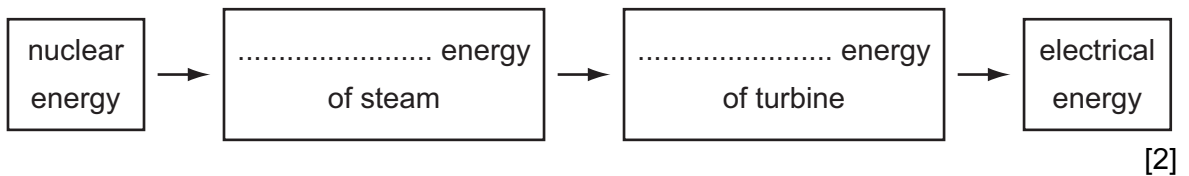



(b) When nuclear fuel is used in a power station, ionising radiation is released.

Table 4.1 shows some information about three types of ionising radiation.

For  
Examiner's  
Use

**Table 4.1**

radiation	ionising power	deflection by electric field
alpha	very strong	small
beta	moderate	large
gamma	weak	none

(i) Explain why alpha and beta radiations are deflected by an electric field but gamma radiation is not.

.....  
..... [1]

(ii) Explain why beta radiation is deflected more than alpha radiation by an electric field.

.....  
..... [1]

(iii) Explain why alpha radiation is the most ionising.

.....  
..... [1]

(iv) State **one** effect of ionising radiation on living things.

.....  
..... [1]

(v) Why are radioactive sources stored in lead containers?

..... [1]

5 Fig. 5.1 shows the female reproductive system.

For  
Examiner's  
Use

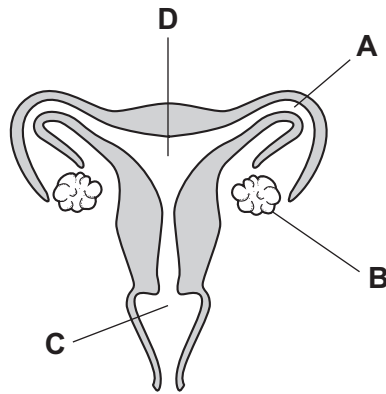

Fig.5.1

(a) Give the **letter** on the diagram which represents each of the following structures.

- vagina .....
- ovary .....
- uterus .....
- oviduct .....

[2]

(b) Fig. 5.2 shows how the thickness of the uterus lining changes during one month of the menstrual cycle.

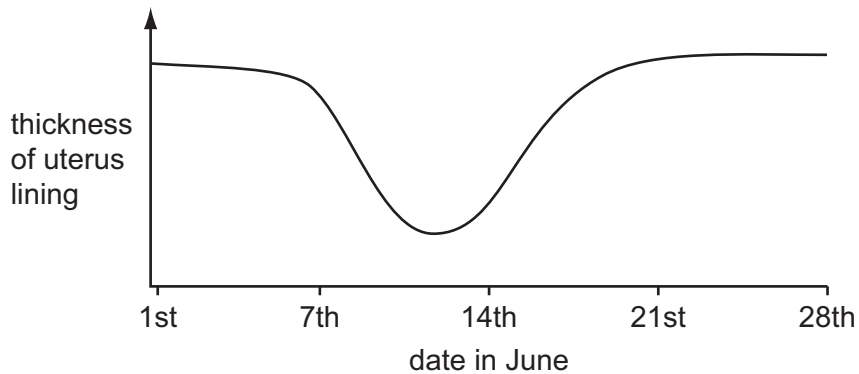

Fig. 5.2

(i) Explain how the graph shows that menstruation began on June 7th.

.....  
 ..... [1]

(ii) Suggest the date on which ovulation (the release of an egg from an ovary) occurred.

..... [1]

(c) During fertilisation, a sperm fuses with an egg.

(i) Name the part of the reproductive system where fertilisation takes place.

..... [1]

(ii) A sperm contains 23 chromosomes.

How many chromosomes does an egg contain?

..... [1]

(iii) Name the part of a sperm or an egg which contains the chromosomes.

..... [1]

(d) (i) AIDS can be transmitted from one person to another during sexual intercourse.

Explain how this transmission can take place.

.....  
.....  
..... [2]

(ii) Outline **two** ways by which the spread of AIDS by this method can be limited.

.....  
.....  
..... [2]

6 Fig. 6.1 shows crude oil (petroleum) being extracted from sedimentary rock under the sea.

For  
Examiner's  
Use

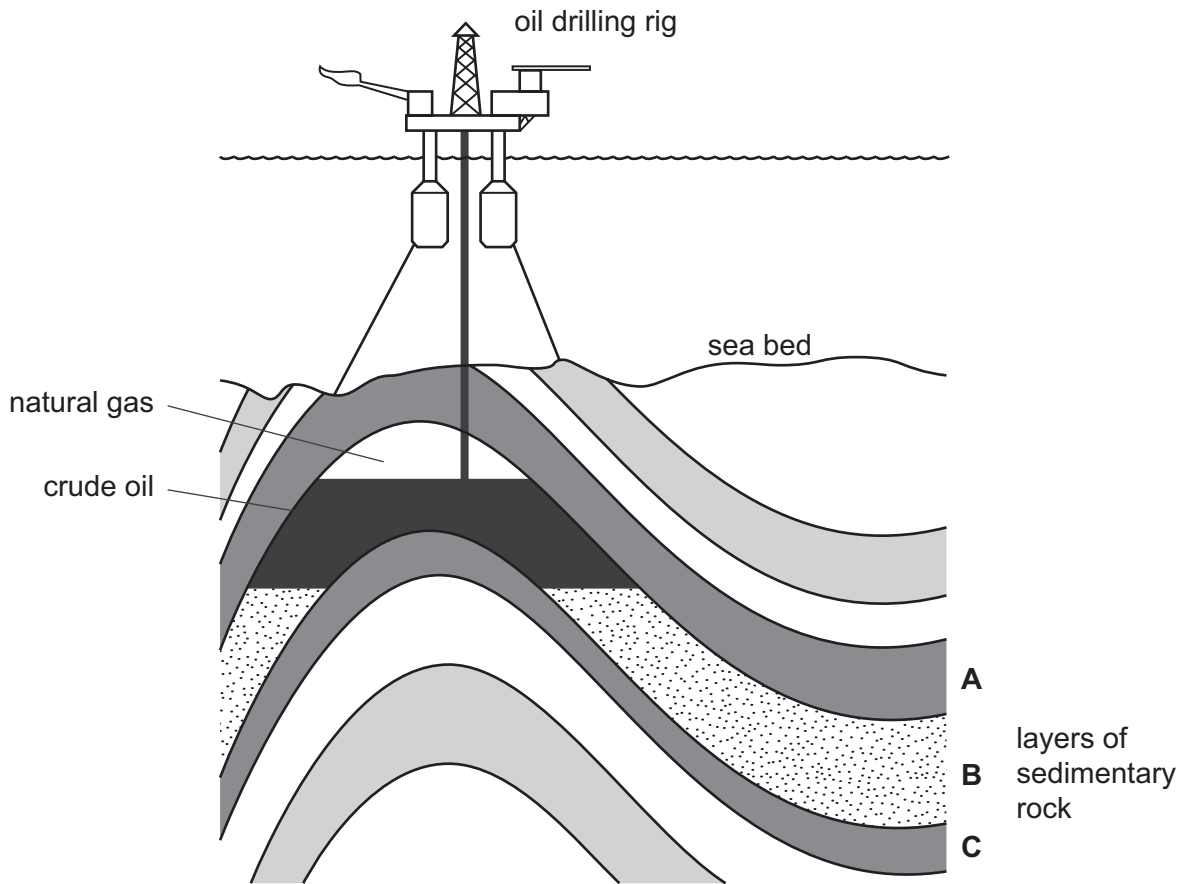

Fig. 6.1

(a) The oil shown in Fig. 6.1 is contained in the layer of sedimentary rock labelled **B**.

(i) Name the two other main types of rock, in addition to sedimentary rocks, which make up the Earth's crust.

1 .....

2 .....

[2]

(ii) The oil in Fig. 6.1 is found only in rock layer **B** and not in layers **A** or **C**.

Suggest the property of rock **B** which is different from rocks **A** and **C**, and which allows it to contain oil.

.....

..... [1]

- (b) Crude oil is a mixture of different hydrocarbon molecules. A typical hydrocarbon molecule is shown in Fig. 6.2.

For  
Examiner's  
Use

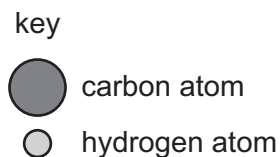

hydrocarbon molecule

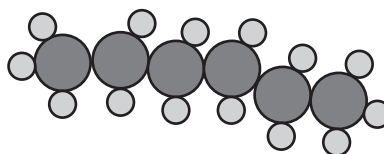

Fig. 6.2

Some hydrocarbon molecules are different from others in crude oil because their carbon atoms form a branched chain as shown in Fig. 6.3.

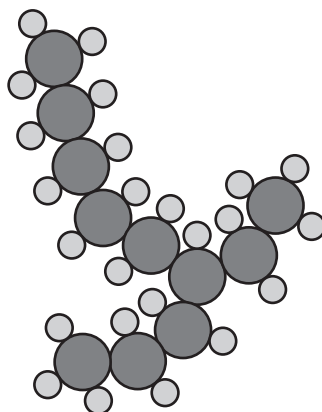

Fig. 6.3

Describe **two** other ways in which hydrocarbon molecules can be different from one another.

1 .....

.....

2 .....

..... [2]

(c) Some hydrocarbons are changed by chemical reactions into a very wide range of materials including plastics. Plastics are made of polymer molecules.

Some of the reactions and processes which are required to produce a typical plastic are shown below. Draw lines linking the statements. One line has already been drawn.

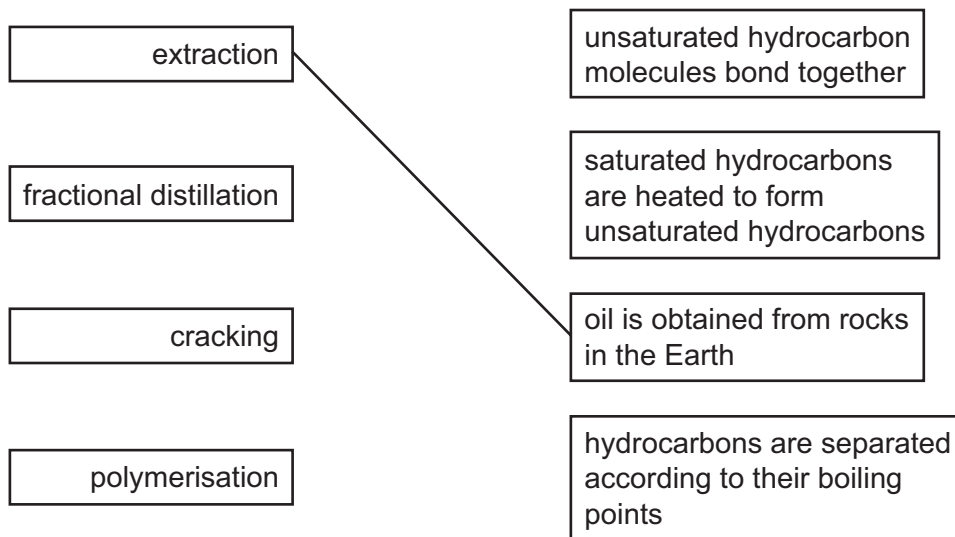

[2]

(d) If an oil tanker is involved in an accident, oil may spill into the sea. If sea birds become covered in crude oil they will die unless the oil can be removed.

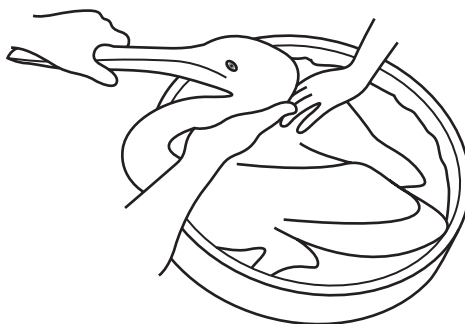

(i) Why is water alone not able to wash the oil from the birds?

.....  
 ..... [1]

(ii) Suggest what could be added to the water in order to remove the oil from the birds.

..... [1]

**BLANK PAGE**

**Please turn over for Question 7**

7 An airline passenger enters an airport.

(a) He buys some hot food at the restaurant and carries it away in a polystyrene container.

Explain why a polystyrene container is used to keep food hot.

.....  
..... [1]

(b) He then moves up an escalator (moving staircase) as shown in Fig. 7.1.

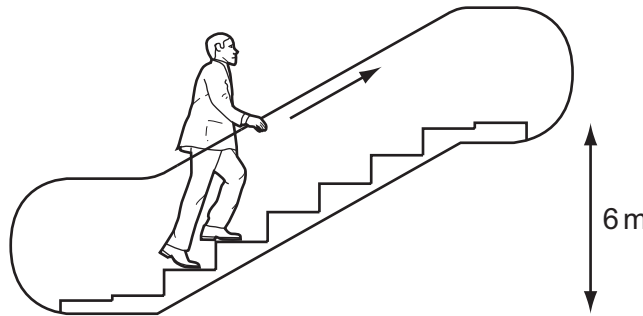

Fig. 7.1

The passenger weighs 900N.

(i) Calculate the work done lifting the passenger a vertical distance of 6 metres.

State the formula that you use and show your working.

formula

working

..... J [2]

(ii) State the potential energy the passenger has gained when he reaches the top of the escalator.

..... J [1]



(c) The aeroplane that the passenger travels on is able to navigate using radar.

This involves the use of microwaves. These are part of the electromagnetic spectrum.

(i) Name **one** other wave which is part of the electromagnetic spectrum.

..... [1]

(ii) State the speed at which these waves travel in a vacuum.

..... m/s [1]

*For  
Examiner's  
Use*

8 Fig. 8.1 shows an alveolus and a blood capillary in the lungs.

For  
Examiner's  
Use

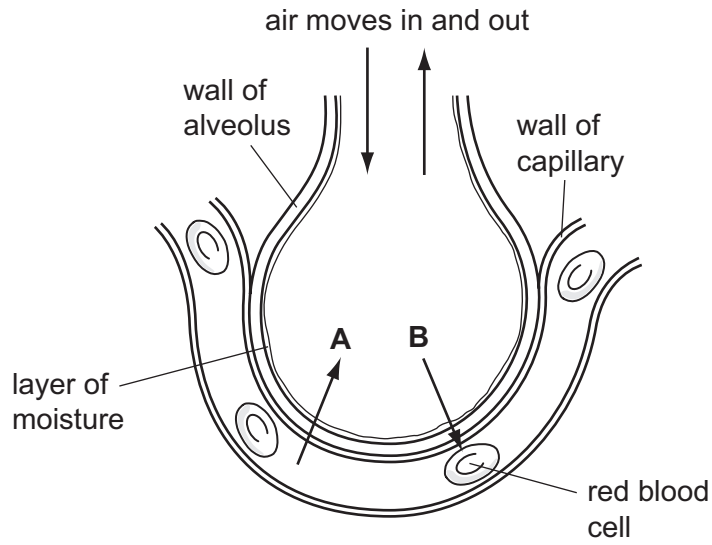

Fig. 8.1

(a) (i) Name the gases that move as indicated by arrows **A** and **B**.

**A** .....

**B** .....

[2]

(ii) Name the process by which the gases move.

.....

[1]

(b) Describe what happens in the red blood cells as they pass through the lungs.

.....

.....

.....

[2]

(c) Fig. 8.2 shows the structure of a leaf.

For  
Examiner's  
Use

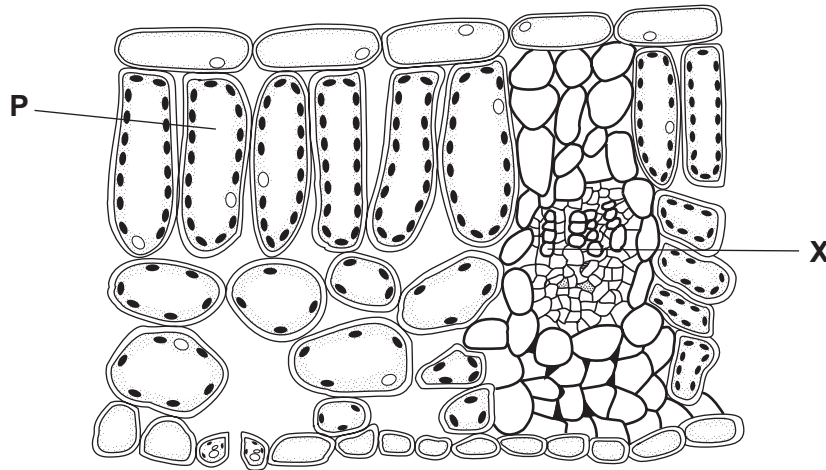

Fig. 8.2

(i) Cell **P** contains many chloroplasts and can photosynthesise.

At night, cell **P** takes in oxygen and gives out carbon dioxide.

In the daytime, cell **P** takes in carbon dioxide and gives out oxygen.

Explain why this happens.

at night .....

.....

in daytime .....

.....

..... [3]

(ii) On Fig. 8.2, draw an arrow to show how gases travel to cell **P** from the air. [1]

(iii) Cell **X** is a xylem vessel.

Give **two** functions of a xylem vessel in a leaf.

1 .....

2 ..... [2]

- 9 Litmus and alizarin yellow are substances which can be used to indicate the pH of a solution. The colours of these substances in solutions of different pH ranges are shown below.

For  
Examiner's  
Use

	pH 4.5 and lower	pH 8.3 and higher
litmus	red	blue

	pH 10.1 and lower	pH 12.0 and higher
alizarin yellow	yellow	brown

- (a) A student wishes to find out if a colourless solution is an acid or an alkali by using one of the substances named above.

Explain why she should use litmus and not alizarin yellow.

.....  
 .....  
 ..... [2]

- (b) Litmus is obtained from plant material and alizarin yellow is a synthetic dye. The chemical formula of alizarin yellow is  $C_{13}H_8N_3NaO_5$ .

- (i) Explain the meaning of the term *synthetic dye*.

.....  
 .....  
 ..... [2]

- (ii) How many metallic elements are shown in the formula of alizarin yellow?

..... [1]

- (iii) Name a method which could be used to find out whether a mixture contained both litmus and alizarin yellow.

..... [1]

(c) The atoms in molecules are joined by covalent chemical bonds.

Explain which **one** of the diagrams, **1** to **4**, shows a covalent bond between the atoms in a chlorine molecule.

For  
Examiner's  
Use

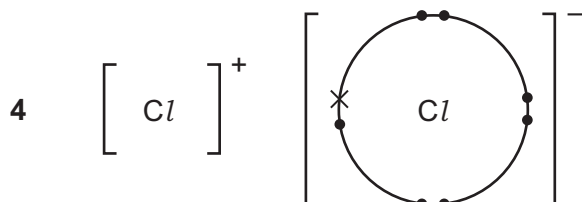
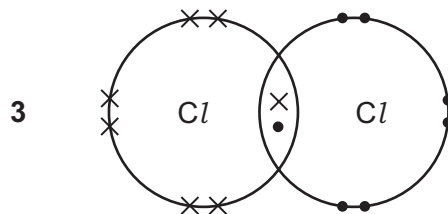
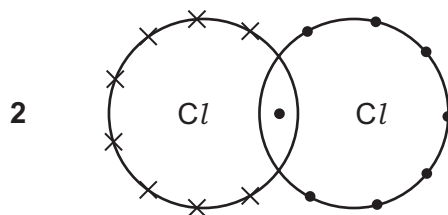
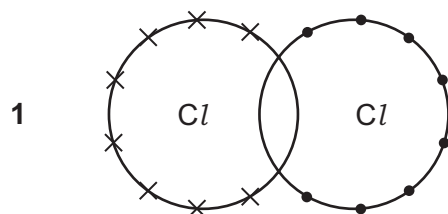

.....  
 .....  
 ..... [2]

10 (a) A simple circuit is shown in Fig. 10.1.

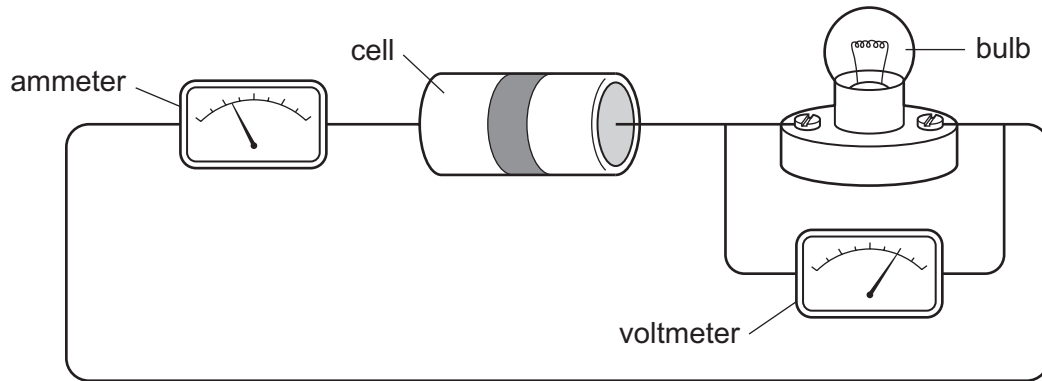

Fig. 10.1

In the space below, draw the circuit diagram for this circuit using the correct symbols.

[3]

(b) Fig. 10.2 shows a d.c. electric motor.

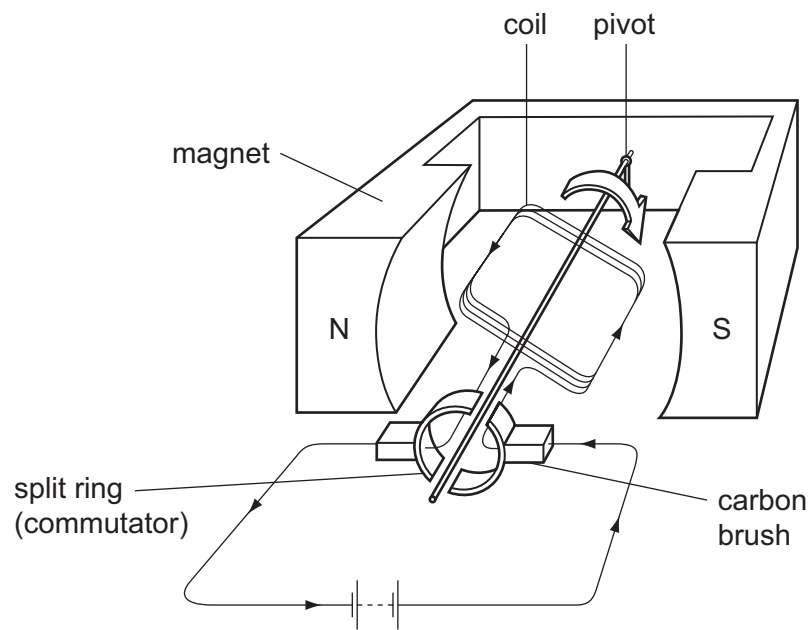

Fig. 10.2

(i) Suggest **two** ways of making the coil spin more quickly.

1 .....

.....

2 .....

..... [2]

(ii) Apart from changing the direction of the current in the coil, how could you reverse the motion of the coil?

..... [1]

(c) An electric motor is connected to a 240V supply.

The maximum current used by the motor is 4 A.

(i) Use the formula **power = voltage x current** to calculate the maximum power put into the motor.

Show your working.

..... W [1]

(ii) Explain why the electrical input power will be greater than the useful mechanical output power.

.....

..... [2]

11 Fig. 11.1 shows the apparatus and substances used by a student to make an electrical cell.

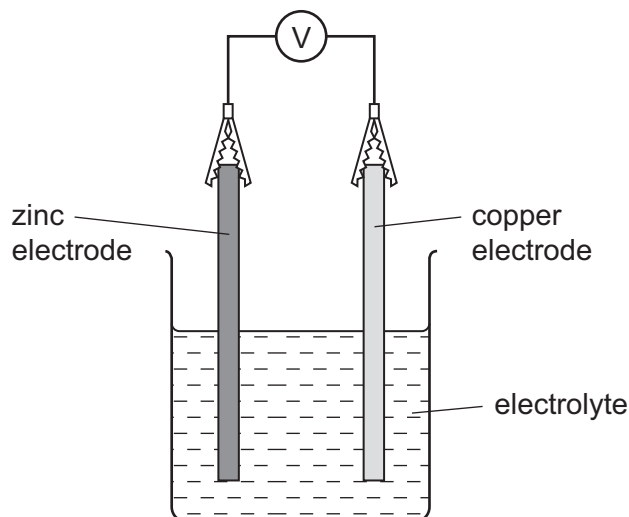

Fig. 11.1

(a) (i) What type of compound must be dissolved in water to produce an electrolyte?

..... [1]

(ii) The student finds that the voltmeter reads 1.1 V.

He then replaces the copper electrode with another electrode made of zinc.

Predict and explain briefly the new voltmeter reading.

.....  
 .....  
 ..... [2]

For  
Examiner's  
Use



(b) In the electrical cell in Fig. 11.1 zinc atoms are converted into positively charged zinc ions,  $\text{Zn}^{2+}$ .

(i) State the number of electrons in one atom of zinc. Use your copy of the Periodic Table on page 28 to help you to answer this question.

..... [1]

(ii) Describe what happens to a zinc atom when it changes into a zinc ion.

.....  
..... [2]

(c) Fig. 11.2 shows an electrical cell used in a personal stereo.



**Fig. 11.2**

The following chemical reaction occurs inside the cell when the stereo is switched on.

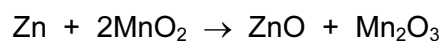

Name the substance which is oxidised in this reaction.

Explain your answer.

substance oxidised

.....

explanation

.....  
..... [2]

**BLANK PAGE**

**BLANK PAGE**

