



UNIVERSITY OF CAMBRIDGE INTERNATIONAL EXAMINATIONS
International General Certificate of Secondary Education

CO-ORDINATED SCIENCES

0654/01

Paper 1 Multiple Choice

October/November 2008

45 minutes

Additional Materials: Multiple Choice Answer Sheet
Soft clean eraser
Soft pencil (type B or HB is recommended)



READ THESE INSTRUCTIONS FIRST

Write in soft pencil.

Do not use staples, paper clips, highlighters, glue or correction fluid.

Write your name, Centre number and candidate number on the Answer Sheet in the spaces provided unless this has been done for you.

There are **forty** questions on this paper. Answer **all** questions. For each question there are four possible answers **A, B, C** and **D**.

Choose the **one** you consider correct and record your choice in **soft pencil** on the separate Answer Sheet.

Read the instructions on the Answer Sheet very carefully.

Each correct answer will score one mark. A mark will not be deducted for a wrong answer.

Any rough working should be done in this booklet.

A copy of the Periodic Table is printed on page 20.

This document consists of **19** printed pages and **1** blank page.



1 The diagram shows four vertebrate animals.

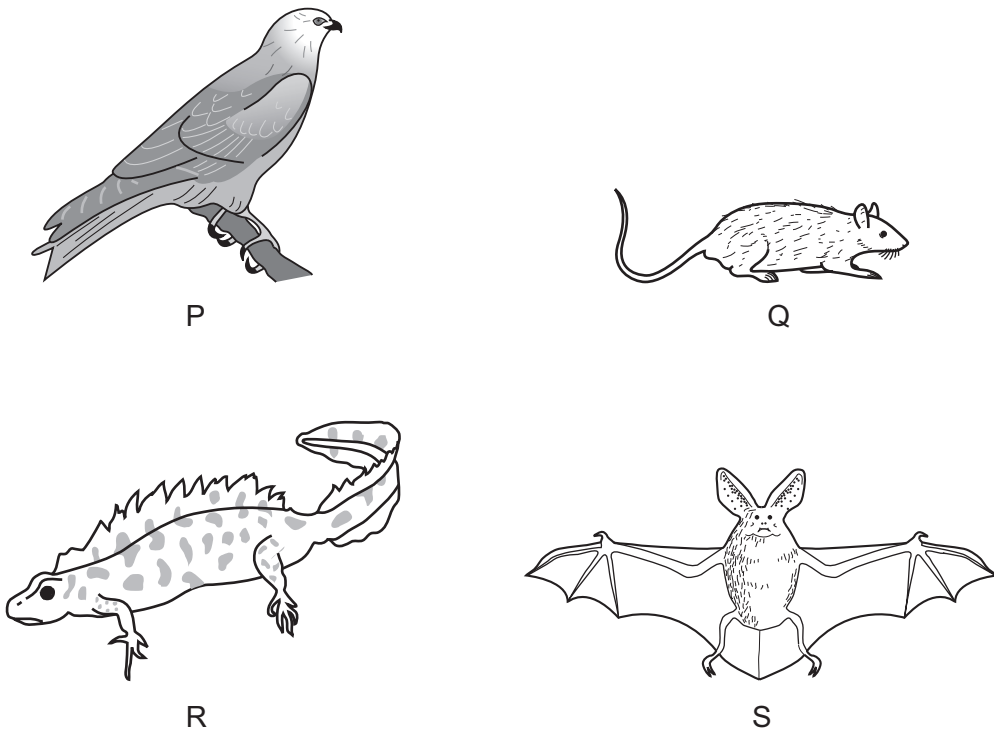

Which two animals belong to the same class?

- A** P and Q **B** P and S **C** Q and R **D** Q and S

2 The diagram shows one kind of blood cell.

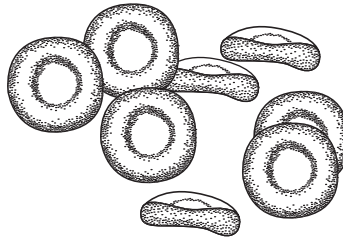

What describes a structural feature and a function of these cells?

	structural features	function
A	have chloroplasts	make glucose
B	have vacuoles	carry oxygen
C	have no cell walls	make glucose
D	have no nuclei	carry oxygen

3 Which shows the sequence that occurs when a person touches a hot object?

- A impulse → stimulus → receptor → spinal cord
- B receptor → stimulus → impulse → brain
- C stimulus → impulse → receptor → spinal cord
- D stimulus → receptor → impulse → brain

4 The diagram shows structures in the throat of a mammal.

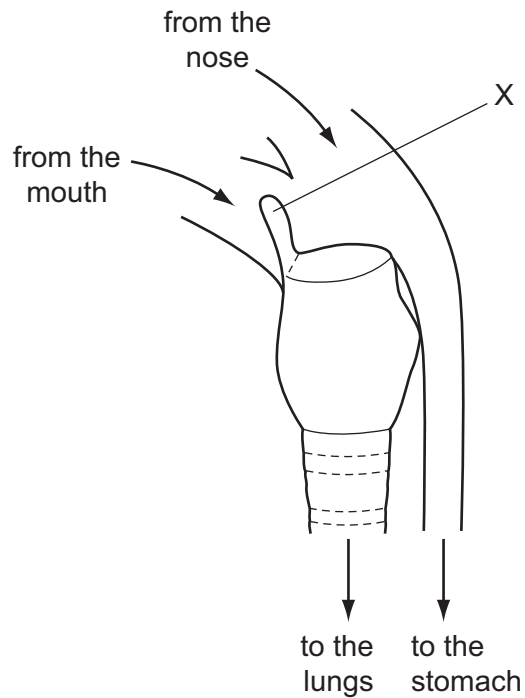

What is X?

- A epiglottis
- B larynx
- C oesophagus
- D trachea

5 In which direction does blood circulate in the body?

- A from the left ventricle through the tricuspid valve
- B from the limbs to the right atrium
- C from the lungs along the pulmonary artery
- D from the right ventricle to the right atrium

- 6 The graph shows the rate of energy release during seed germination.

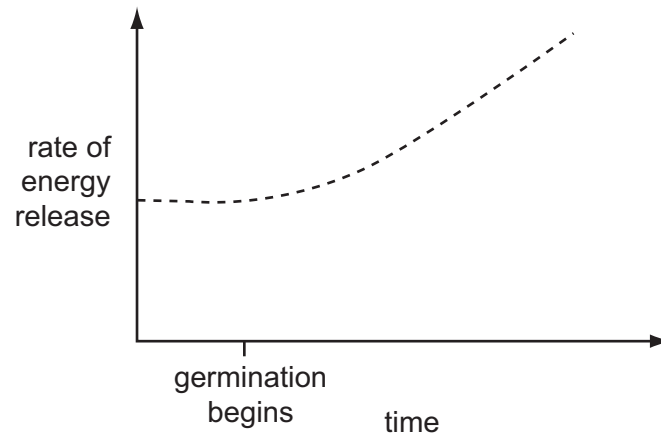

Which process uses this energy?

- A growth
 - B photosynthesis
 - C respiration
 - D transpiration
- 7 Muscle wastage, lack of growth and the accumulation of fluid in tissues are conditions which result from the lack of nutrient X in the diet.

What is nutrient X?

- A calcium
- B carbohydrate
- C fat
- D protein

8 The diagram shows a synovial joint.

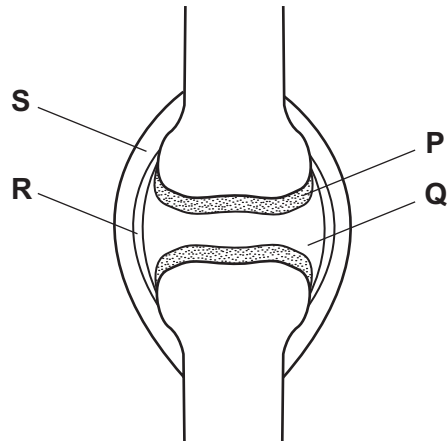

Which two parts prevent friction between the bones?

- A** P and Q **B** P and R **C** Q and R **D** Q and S

9 The graph shows body temperature before, during and after running a race on a hot day.

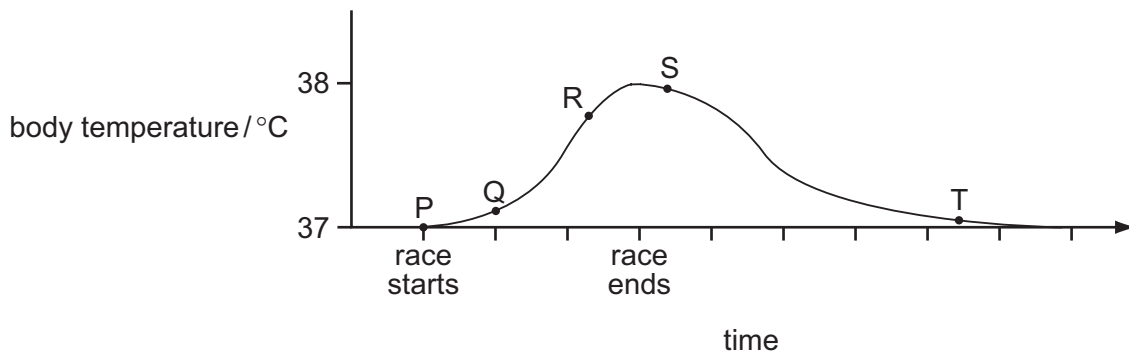

Which stage of the graph occurs as a result of homeostasis?

- A** P to Q **B** Q to R **C** R to S **D** S to T

10 A student placed four sets of seeds in different conditions.

Which set of conditions must be kept constant to show the effect of temperature on germination?

- A** temperature and water only
B temperature only
C temperature, water and oxygen
D water and oxygen only

11 The diagram shows a fetus in a uterus.

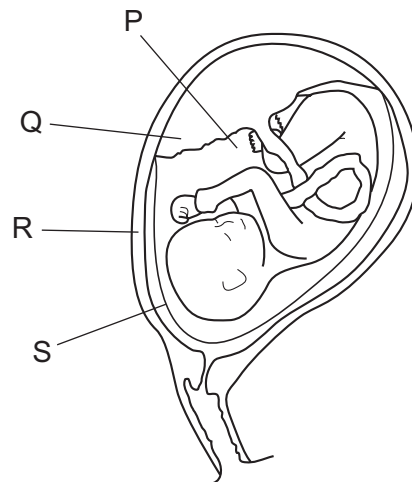

Which parts enable pressure to be spread evenly around the fetus?

- A** P and Q **B** P and S **C** Q and R **D** R and S

12 Cystic fibrosis is an inherited disease.

Only people who are homozygous recessive, ff, suffer from this disease.

Which cross could **not** give rise to a child suffering from cystic fibrosis?

- A** FF × ff **B** Ff × Ff **C** Ff × ff **D** ff × ff

13 Which process is responsible for the flow of energy along a food chain?

- A** feeding
B pollination
C respiration
D seed dispersal

14 Element X has a proton number of 24 and a nucleon number of 52.

How many electrons and neutrons are there in an atom of X?

	electrons	neutrons
A	24	28
B	24	52
C	28	24
D	28	52

15 An element E is a metal.

In which Group of the Periodic Table could E occur and which type of oxide does E form?

	Group	type of oxide
A	I	basic
B	III	acidic
C	VI	basic
D	VII	acidic

16 Large hydrocarbons can be1..... to make smaller, more useful molecules.

Small hydrocarbon molecules can be2..... to make long molecules.

Which words correctly complete gaps 1 and 2?

	1	2
A	cracked	distilled
B	cracked	polymerised
C	distilled	polymerised
D	distilled	cracked

17 A chemical from a plant is tested.

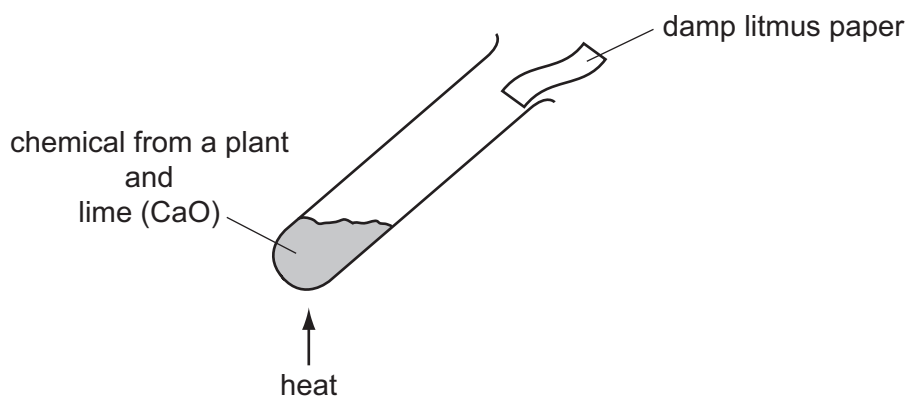

An alkaline gas, ammonia (NH_3), is produced.

What is the chemical from the plant?

- A** cellulose
- B** a protein
- C** starch
- D** a sugar

18 Glass may be produced by two processes.

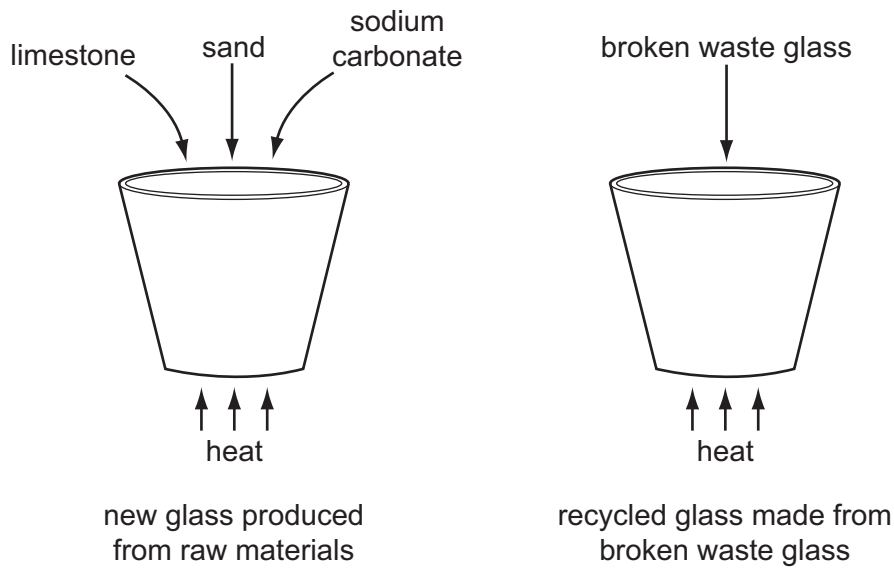

Which statements are arguments against the recycling of glass?

- 1 Raw materials for new glass manufacture are plentiful.
- 2 Waste glass causes litter and injuries, if the glass is broken.
- 3 Waste glass is not biodegradable.

A 1 only **B** 1 and 3 only **C** 2 and 3 only **D** 1, 2 and 3

19 The table shows information about some minerals in rocks.

name	chemical formula
bauxite	Al_2O_3
galena	PbS
hematite	Fe_2O_3
rutile	TiO_2

From which two minerals can a transition element be extracted?

- A** bauxite and galena
- B** bauxite and hematite
- C** galena and rutile
- D** hematite and rutile

20 Which substances can be obtained from rocks?

- A ethene and carbohydrates
- B ethene and metals
- C lime and carbohydrates
- D lime and metals

21 Electrolysis of sodium chloride is used to obtain chlorine.

In what form is sodium chloride electrolysed and at which electrode is the chlorine obtained?

	form of sodium chloride	electrode at which chlorine is obtained
A	in aqueous solution	anode
B	in aqueous solution	cathode
C	solid	anode
D	solid	cathode

22 Tap water often contains compounds dissolved from rocks.

The list shows four minerals present in rocks.

- 1 gypsum, CaSO_4
- 2 magnesite, MgCO_3
- 3 rock salt, NaCl
- 4 quartz, SiO_2

Which of these minerals cause hardness in tap water?

- A 1 and 2 only
- B 1 and 3 only
- C 2 and 3 only
- D 2 and 4 only

- 23 A soil is treated with lime. As a result, a plant that was growing well becomes discoloured and dies.

Which conditions suit the plant?

	likes calcium ions in soil	likes alkaline soil	
A	✓	✓	key ✓ = correct x = not correct
B	✓	x	
C	x	✓	
D	x	x	

- 24 Testing for which ion in solution involves reduction of the ion?

- A ammonium
- B chloride
- C nitrate
- D sulphate

- 25 Which types of substance can be obtained from plant material?

	alloys	drugs	dyes
A	✓	✓	✓
B	✓	x	x
C	x	✓	✓
D	x	x	✓

26 The diagram shows waste organic material decaying.

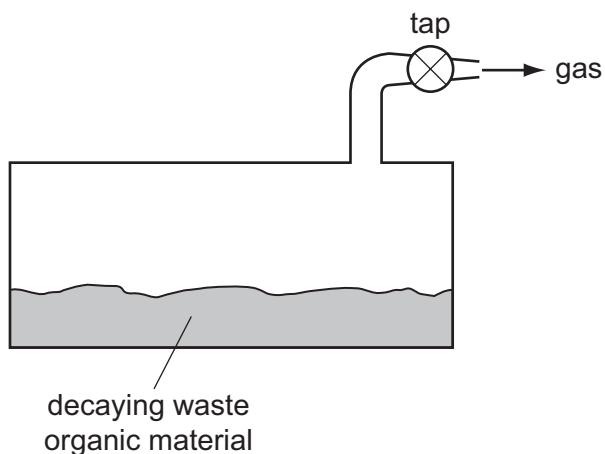

What is formed when the gas is burned?

- A carbon dioxide and water
- B carbon dioxide only
- C carbon monoxide only
- D water only

27 The diagram shows part of the Periodic Table.

Which element has the greatest number of outer electrons in its atoms?

		<input type="checkbox"/>															A		
		B																	
C																			D

28 A car travels at various speeds during a short journey.

The table shows the distances travelled and the time taken during each of four stages P, Q, R and S.

stage	P	Q	R	S
distance travelled / km	1.8	3.6	2.7	2.7
time taken / minutes	2	2	4	3

During which two stages is the car travelling at the same speed?

- A** P and Q **B** P and S **C** Q and R **D** R and S

29 Two identical measuring cylinders containing different liquids are placed on a simple balance.

They balance as shown.

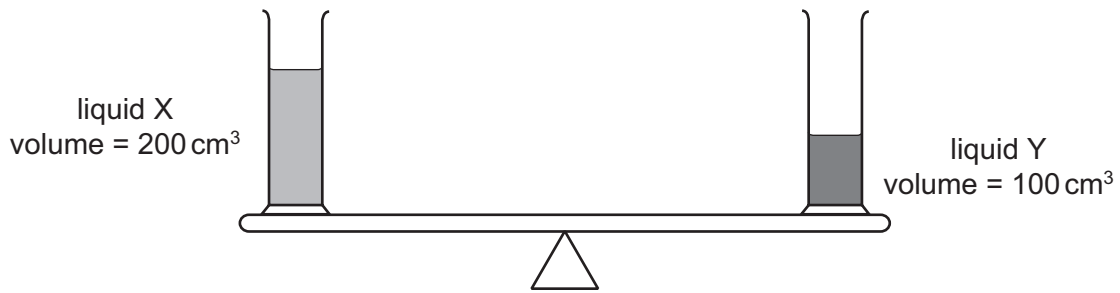

How does the density of X compare with the density of Y?

- A** density of X = $\frac{1}{2}$ × density of Y
B density of X = density of Y
C density of X = 2 × density of Y
D density of X = 4 × density of Y

- 30 A train is travelling along a horizontal track at constant speed. Two of the forces acting on the train are shown in the diagram.

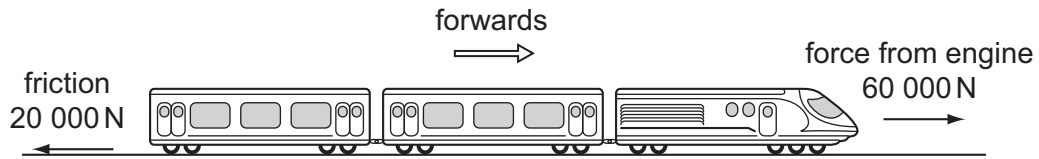

A force of air resistance is also acting on the train so that the forces balance.

What is this air resistance force?

- A 40 000 N backwards
 - B 80 000 N backwards
 - C 40 000 N forwards
 - D 80 000 N forwards
- 31 A rubber ball is dropped from a height of 2 metres onto a table.

Whilst in contact with the table, some of its energy is converted into heat energy.

What is the highest possible point the ball could reach after bouncing?

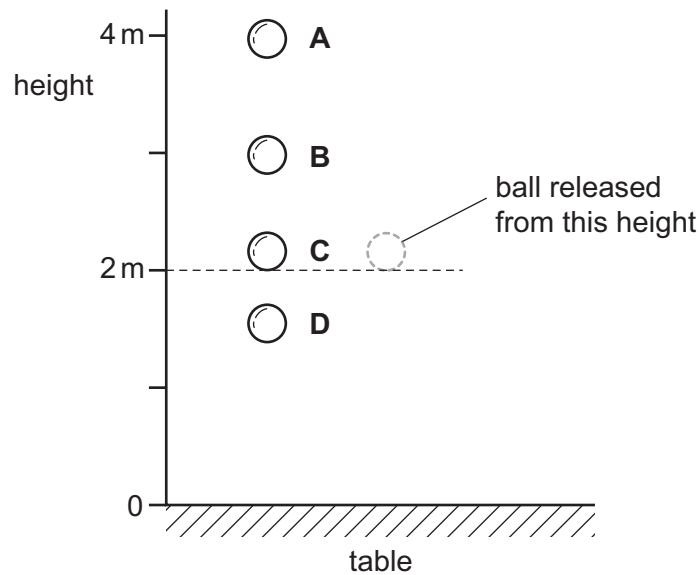

32 A brick with rectangular sides rests on a table.

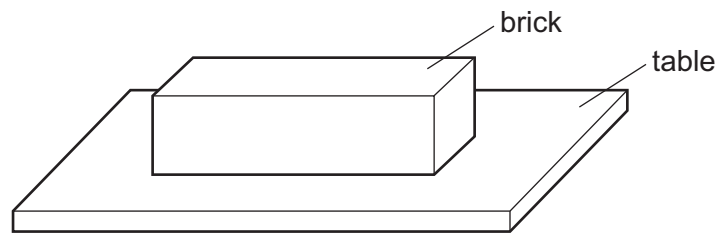

The brick is now turned so that it rests on the table on its smallest face.

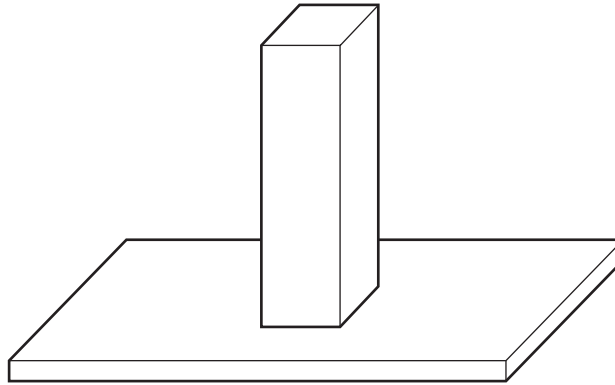

How has this change affected the force and the pressure exerted by the brick on the table?

	force	pressure
A	unchanged	unchanged
B	increased	unchanged
C	unchanged	increased
D	increased	increased

- 33 The pressure of a fixed mass of gas in a cylinder is measured. The volume of the cylinder is then slowly decreased.

Which graph could show the change of pressure of the gas during this process?

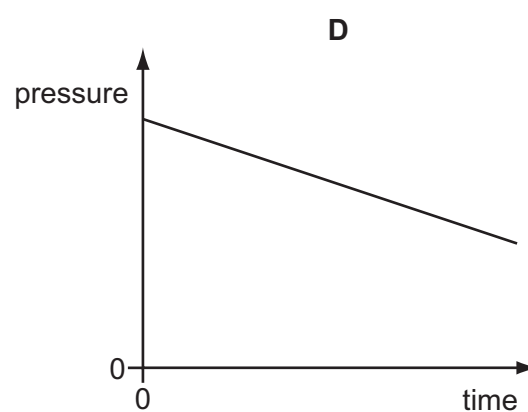
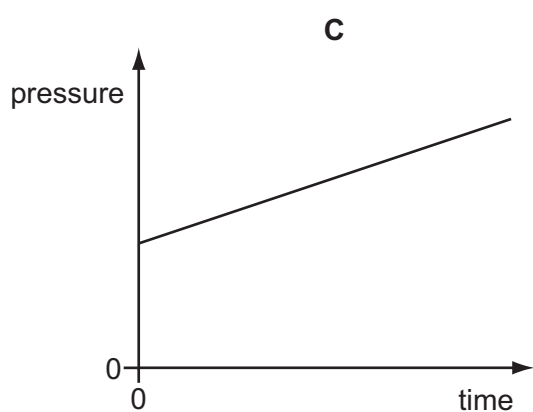
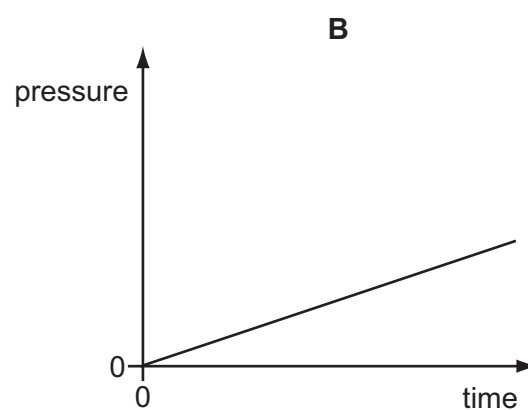
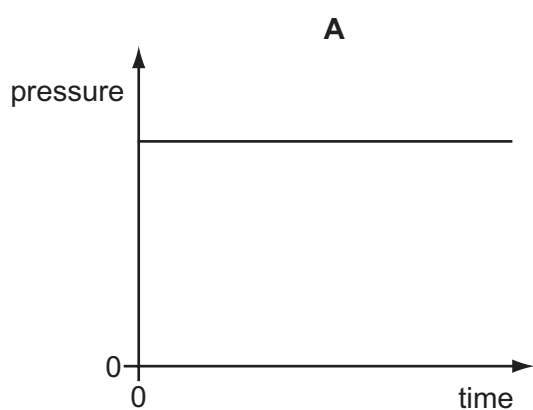

- 34 Equal masses of two different liquids are heated using the same heater. The graph shows how the temperature of each liquid changes with time.

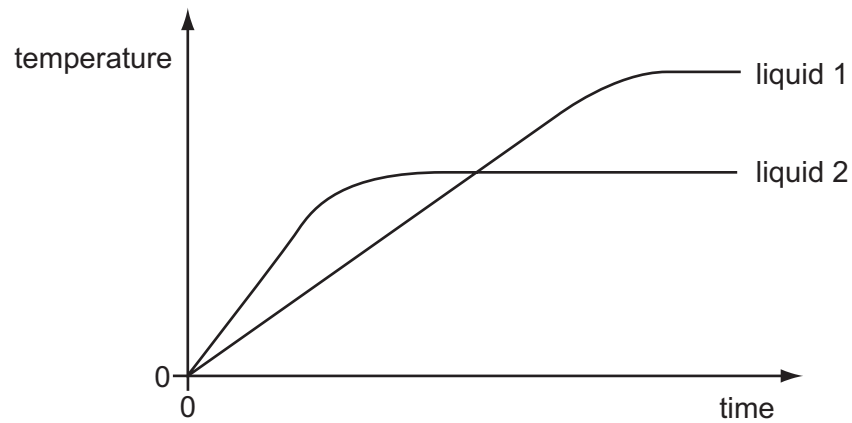

What does the graph tell us about the liquids?

- A Liquid 1 has a higher melting point than liquid 2.
 - B Liquid 1 has a higher boiling point than liquid 2.
 - C Liquid 1 starts to melt sooner than liquid 2.
 - D Liquid 1 starts to boil sooner than liquid 2.
- 35 A white plastic lid is placed on a plastic cup used for a hot drink.

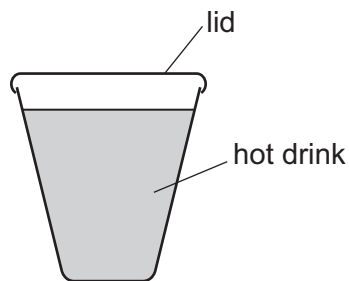

This would have no effect on the loss of heat by

- A conduction.
- B convection.
- C evaporation.
- D radiation.

36 In the diagram, the distance OP is the focal length of the lens.

Through which point will the ray shown pass, after refraction by the lens?

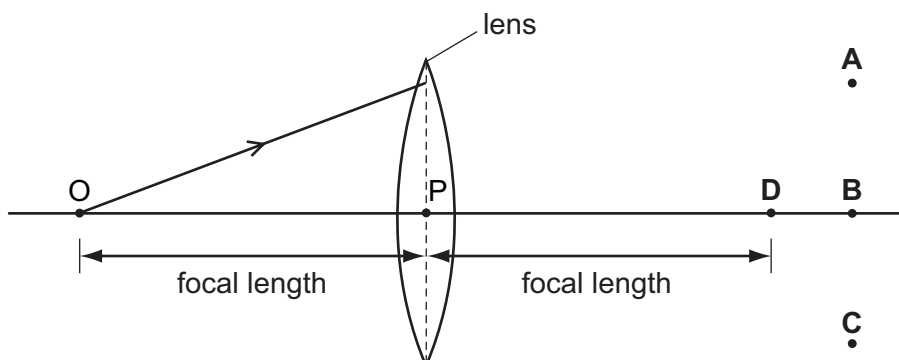

37 The table shows the voltage and current ratings for four electric heaters.

Which heater has the least resistance?

	voltage/V	current/A
A	110	5.0
B	110	10.0
C	230	5.0
D	230	10.0

38 In the circuit below, X and Y are identical 6 V lamps.

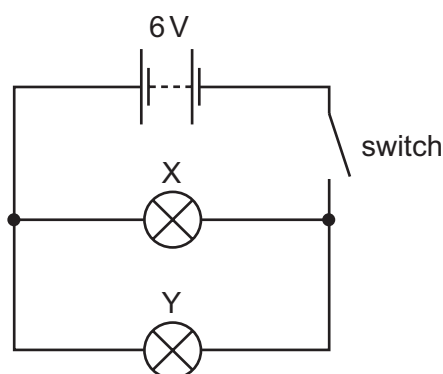

What happens when the switch is closed (the current is switched on)?

- A** X lights more brightly than Y.
- B** Y lights more brightly than X.
- C** X and Y both light with full brightness.
- D** X and Y both light with half brightness.

- 39 Two different systems are used to transmit equal amounts of electrical power from one building to another.

One system uses low voltage and the other uses high voltage.

Which line in the table is correct about which system wastes least energy and why?

	least energy wasted	why
A	high voltage system	the current in the wires is bigger
B	high voltage system	the current in the wires is smaller
C	low voltage system	the current in the wires is bigger
D	low voltage system	the current in the wires is smaller

- 40 The diagram shows an experiment to monitor the radiation from a radioactive gas. The counter readings are corrected for background radiation.

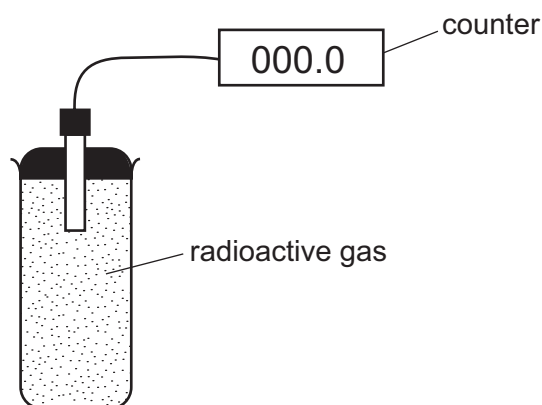

The table shows how the counter reading varies with time.

time / seconds	0	20	40	60	80	100	120	140	160	180
counter reading / counts per minute	140	105	82	61	44	36	27	20	15	10

What is the half-life of the gas?

- A** between 20 and 40 seconds
- B** between 40 and 60 seconds
- C** between 60 and 140 seconds
- D** between 140 and 180 seconds

BLANK PAGE

DATA SHEET
The Periodic Table of the Elements

		Group																																																																					
I	II	III	IV	V	VI	VII	0																																																																
7 Li Lithium 3	9 Be Beryllium 4	1 H Hydrogen 1	11 B Boron 5	12 C Carbon 6	14 N Nitrogen 7	16 O Oxygen 8	19 F Fluorine 9	20 Ne Neon 10	23 Na Sodium 11	24 Mg Magnesium 12	27 Al Aluminium 13	28 Si Silicon 14	31 P Phosphorus 15	32 S Sulphur 16	35.5 Cl Chlorine 17	40 Ar Argon 18	39 K Potassium 19	40 Ca Calcium 20	45 Sc Scandium 21	48 Ti Titanium 22	51 V Vanadium 23	52 Cr Chromium 24	55 Mn Manganese 25	56 Fe Iron 26	59 Co Cobalt 27	59 Ni Nickel 28	64 Cu Copper 29	65 Zn Zinc 30	70 Ga Gallium 31	73 Ge Germanium 32	75 As Arsenic 33	79 Se Selenium 34	80 Br Bromine 35	84 Kr Krypton 36	85 Rb Rubidium 37	88 Sr Strontium 38	89 Y Yttrium 39	91 Zr Zirconium 40	93 Nb Niobium 41	96 Mo Molybdenum 42	101 Ru Ruthenium 44	106 Pd Palladium 46	108 Ag Silver 47	112 Cd Cadmium 48	115 In Indium 49	119 Sn Tin 50	122 Sb Antimony 51	127 I Iodine 53	131 Xe Xenon 54	133 Cs Caesium 55	137 Ba Barium 56	139 La Lanthanum 57	178 Hf Hafnium 72	181 Ta Tantalum 73	184 W Tungsten 74	186 Re Rhenium 75	190 Os Osmium 76	192 Ir Iridium 77	195 Pt Platinum 78	197 Au Gold 79	201 Hg Mercury 80	204 Tl Thallium 81	207 Pb Lead 82	209 Bi Bismuth 83	210 Po Polonium 84	210 At Astatine 85	226 Ra Radium 88	227 Ac Actinium 89	87	88	89
												140 Ce Cerium 58	141 Pr Praseodymium 59	144 Nd Neodymium 60	150 Sm Samarium 62	152 Eu Europium 63	157 Gd Gadolinium 64	159 Tb Terbium 65	162 Dy Dysprosium 66	165 Ho Holmium 67	167 Er Erbium 68	169 Tm Thulium 69	173 Yb Ytterbium 70	175 Lu Lutetium 71	232 Th Thorium 90	238 U Uranium 92	238 Pa Protactinium 91	238 Np Neptunium 93	238 Pu Plutonium 94	238 Am Americium 95	238 Cm Curium 96	238 Bk Berkelium 97	238 Cf Californium 98	238 Es Einsteinium 99	238 Fm Fermium 100	238 Md Mendelevium 101	238 No Nobelium 102	238 Lr Lawrencium 103																																	

*58-71 Lanthanoid series
†90-103 Actinoid series

Key

a	X	a = relative atomic mass
b	X	X = atomic symbol
		b = proton (atomic) number

The volume of one mole of any gas is 24 dm³ at room temperature and pressure (r.t.p.).

Permission to reproduce items where third-party owned material protected by copyright is included has been sought and cleared where possible. Every reasonable effort has been made by the publisher (UCLES) to trace copyright holders, but if any items requiring clearance have unwittingly been included, the publisher will be pleased to make amends at the earliest possible opportunity.

University of Cambridge International Examinations is part of the Cambridge Assessment Group. Cambridge Assessment is the brand name of University of Cambridge Local Examinations Syndicate (UCLES), which is itself a department of the University of Cambridge.