



UNIVERSITY OF CAMBRIDGE INTERNATIONAL EXAMINATIONS
International General Certificate of Secondary Education

CANDIDATE
NAME

CENTRE
NUMBER

--	--	--	--	--

CANDIDATE
NUMBER

--	--	--	--

* 1 2 5 4 1 9 5 6 1 0 *

**COMBINED SCIENCE
CO-ORDINATED SCIENCES**

**0653/06
0654/06**

Paper 6 Alternative to Practical

October/November 2007

1 hour

Candidates answer on the Question Paper.

No Additional Materials are required.

READ THESE INSTRUCTIONS FIRST

Write your Centre number, candidate number and name on all the work you hand in.

Write in dark blue or black pen.

You may use a soft pencil for any diagrams, graphs, tables or rough working.

Do not use staples, paper clips, highlighters, glue or correction fluid.

DO NOT WRITE IN ANY BARCODES.

Answer **all** questions.

At the end of the examination, fasten all your work securely together.

The number of marks is given in brackets [] at the end of each question or part question.

For Examiner's Use	
1	
2	
3	
4	
5	
6	
Total	

This document consists of **14** printed pages and **2** blank pages.



- 1 (a) A student did an experiment on two raisins. She put raisin **A** to soak overnight in a dilute sugar solution. Raisin **B** was left unsoaked. Fig. 1.1 shows the diagrams of the raisins drawn by the student.



Fig. 1.1

- (i) Compare the appearance of the raisins. Describe what has happened to the shape of raisin **A** while it was in the solution.

.....
 [1]

The student weighed the raisins at the start of the experiment. She recorded the result in Fig. 1.3.

- (ii) Study the balance windows in Fig. 1.2. These show the final masses of the two raisins at the end of the experiment. Read the masses shown and record the results in Fig. 1.3. [2]

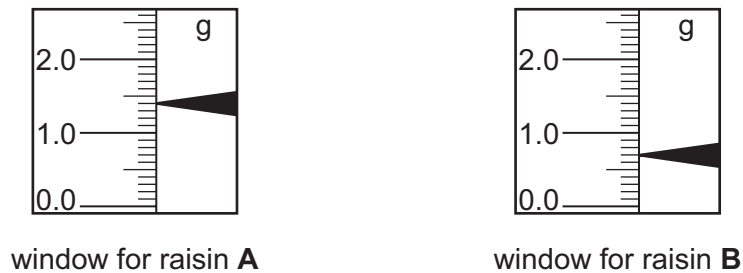

Fig. 1.2

- (iii) Calculate the changes in mass for the raisins and write your answers in Fig.1.3. [2]

raisin	mass at start/g	mass at end/g	change in mass/g
A	0.9		
B	0.8		

Fig. 1.3

(iv) Explain the change in mass of raisin **A** by referring to the concentrations (water potentials) of the raisin cells and the solution in which raisin **A** was immersed.

.....
.....
.....
..... [3]

(v) Suggest why the mass of raisin **B** has changed.

..... [1]

(b) The student was given two sugar solutions of different concentration (water potential). How could the experiment be modified to find which solution is the more concentrated?

.....
.....
.....
.....
.....
..... [4]

- 2 The teacher gave two students a set of three colourless solutions, labelled **X**, **Y** and **Z**. He also gave them solution **P** which is an indicator. Solution **P** is colourless in an acidic solution but pink in an alkaline solution.

The students added solution **P** to samples of the solutions **X**, **Y** and **Z**. Fig. 2.1 shows the results.

solution X	solution Y	solution Z
colourless	pink	pink

Fig. 2.1

- (a) Decide whether solutions **X**, **Y** and **Z** are acidic or alkaline.

solution **X**

solution **Y**

solution **Z**

[2]

- (b) The students wanted to deduce the name of the acid. They carried out a test that showed that the acid contained sulphate ions.

- (i) Name the reagent that they added to the acid.

..... [1]

- (ii) Describe what they observed when this reagent was added to the acid.

..... [1]

- (iii) Name the acid.

..... [1]

- (c) The students placed about 1 cm³ of solution **Y** in a test-tube and added one drop of solution **P**.

Then they added solution **X**, a few drops at a time. After a few drops had been added there was no change in colour, but when more drops of solution **X** had been added, the colour changed.

- (i) There was no change in colour when the first few drops of solution **X** had been added. Why was this?

.....

..... [1]

(ii) Suggest how the colour changed when more drops of solution **X** were added.

The colour changed from to [1]

(iii) What kind of reaction took place between solution **X** and solution **Y**?

..... [1]

(d) Fig. 2.2 shows the result of two more experiments that the students carried out. Study their observations and then suggest the names of solutions **Y** and **Z**.

	test	result
1	1 cm ³ of zinc sulphate solution was placed in a test-tube, then solution Y was added a little at a time.	At first there was a white precipitate that dissolved when more solution Y was added.
2	1 cm ³ of solution Z was placed in a test-tube. Then solution X was added.	The mixture bubbled. A gas was given off that turned limewater milky

Fig. 2.2

name of solution **Y**

name of solution **Z**

[2]

- 3 A student investigated the way in which the current through a resistance wire varied with the length of the wire. He used the circuit shown in Fig. 3.1.

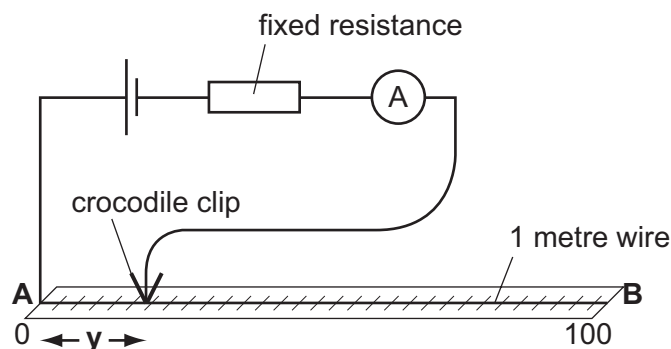

Fig. 3.1

The resistance wire, 100 cm long, was fixed on to a metre ruler. One metre of the resistance wire had a resistance of 4.5 ohms.

- The student touched the wire with the contact and noted length y , and I , the reading of the ammeter.
- He noted these readings in the first and third columns of Fig.3.2.
- He repeated this procedure, choosing different lengths of wire each time.
- He calculated the resistance R of the length of wire, y , used for each reading.
- He found V , the potential drop for each length of wire by multiplying the resistance R by the current I .

length of wire y /cm	resistance of wire R /ohms	ammeter reading I /amps	potential drop V /volts
10	0.45	0.81	0.36
25			
40	1.80		
60			
70	3.15	0.39	1.2

Fig. 3.2

- (a) (i) Fig. 3.3 shows the ammeter dials for the three missing readings.
Read the ammeters and record the readings in the third column of Fig. 3.2. [3]

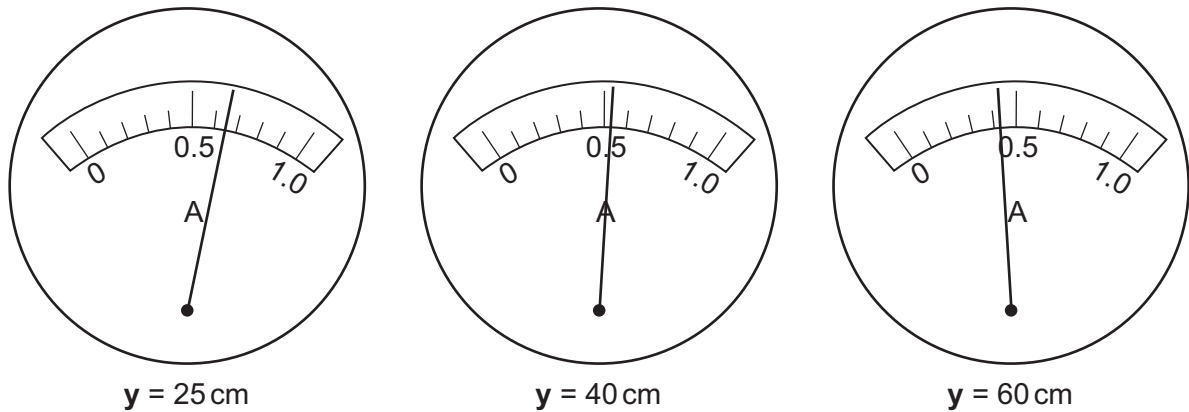

Fig. 3.3

- (ii) Calculate **R**, the resistance of the 25 cm and 60 cm lengths of wire by using the formula.

$$R = \frac{4.5 \times y}{100} \text{ ohms}$$

Record the values in the second column of Fig. 3.2. [1]

- (iii) Complete the last column of Fig. 3.2 by calculating the missing values for **V**, the potential drop.
Use the following formula;

$$V = R \times I \text{ volts} \quad [1]$$

- (b) Plot a graph of V , the potential drop against y , the length of the wire. Plot y on the horizontal axis. Join the points by a smooth curve that passes through the point $(0,0)$. [3]

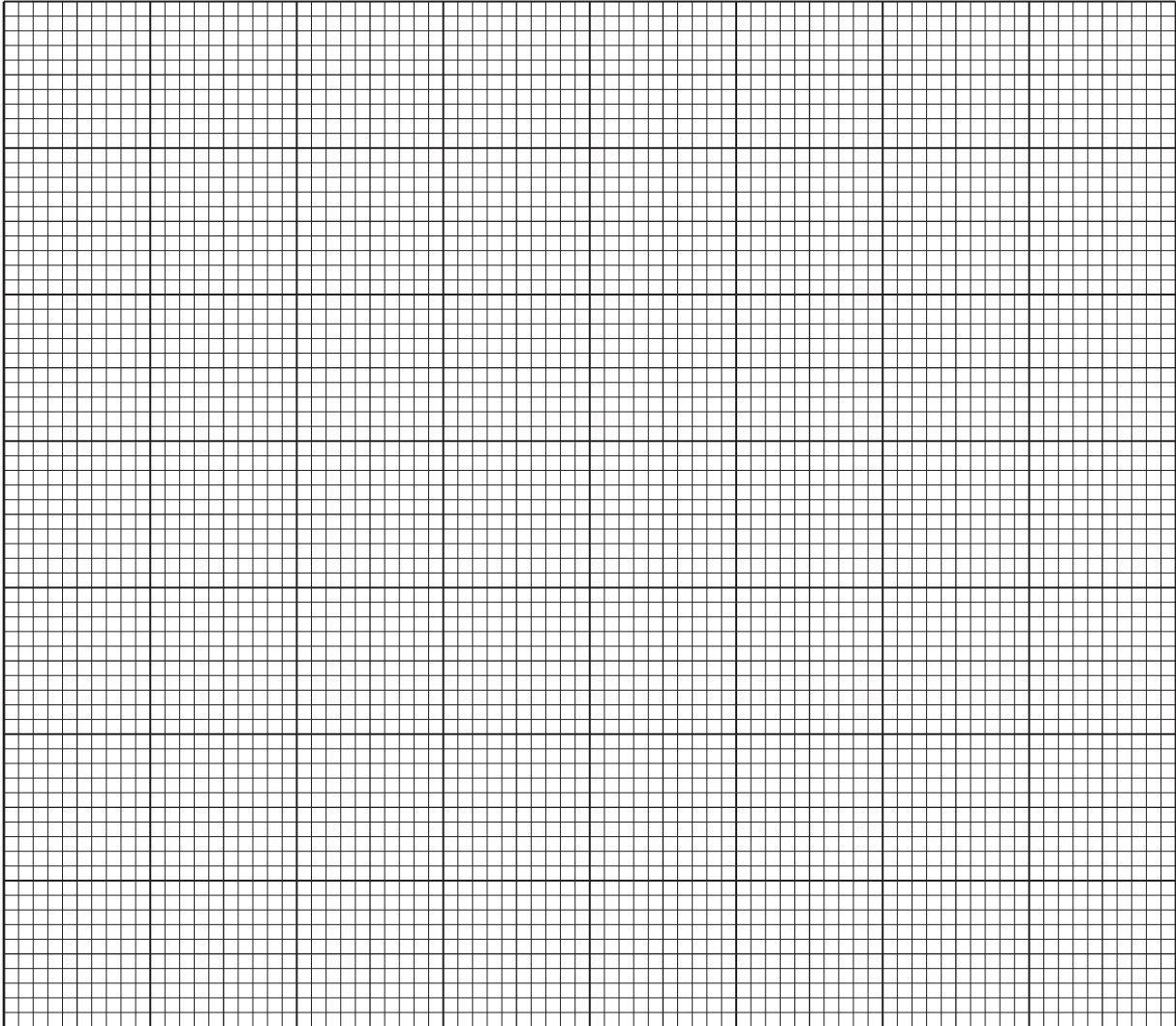

- (c) The experiment is repeated using a cell with a larger voltage but the same wire. Draw a second curve on your graph to show the result you would expect. Explain how you decided this. Label this curve "expected result". [2]

4 In animals the kidneys produce urine to remove waste products from the body. Healthy urine does not contain protein or sugar, but it does contain chloride ions. The four solutions, **D**, **E**, **F**, and **G**, were urine samples from the following people.

- a diabetic patient's urine containing reducing sugar
- a patient with kidney failure whose urine contained protein
- a healthy person's urine
- a sample that is not genuine urine (fake sample), it is just coloured water.

A student used Benedict's and biuret solutions to identify the samples from patients with diabetes and with kidney failure.

Sample **F** was from the diabetic person and it contained reducing sugar.

Sample **G** came from the patient with kidney failure and this contained protein.

(a) Complete the first **two** lines of Fig. 4.1 below to show the colours of the mixtures after the urine samples were added to the Benedict's and biuret solutions.

test on urine	sample D	sample E	sample F	sample G
Benedict's test				
biuret test				
chloride test				

Fig. 4.1 [4]

(b) Samples **D** and **E** appeared to come from healthy people, but one of the samples was not genuine. The student tested both samples for the presence of chloride ions. She found that sample **D** was the fake.

(i) Name the reagent the student used to test for chloride ions.

..... [1]

(ii) Complete the last line of Fig. 4.1 to show the results of the chloride test. [1]

(c) Describe **one** way the student ensured that her tests were fair.

.....
..... [1]

- 5 A series of experiments was done to find out how temperature change affects the speed of reaction. Marble (calcium carbonate) was reacted with dilute hydrochloric acid at different temperatures.

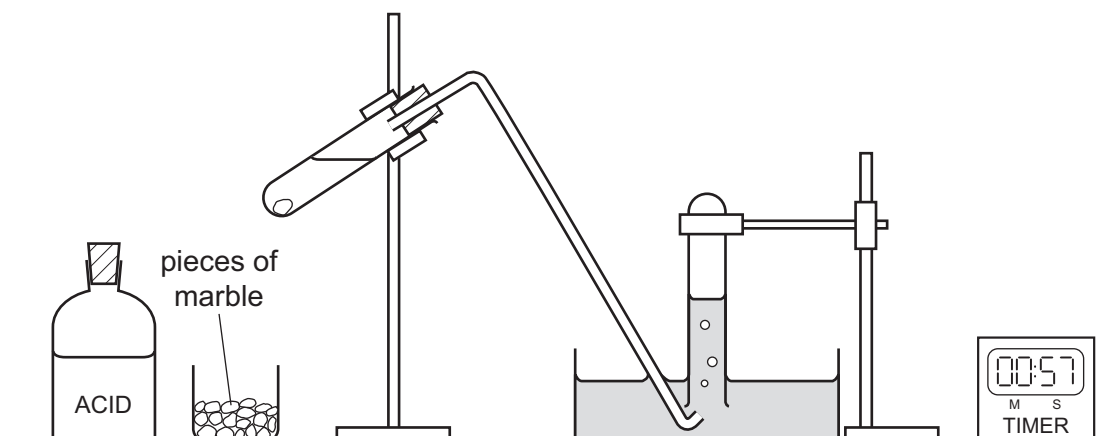

Fig. 5.1

- A test-tube was half-filled with dilute hydrochloric acid.
- The acid was gently warmed and its temperature was recorded in Fig. 5.2.
- A small piece of marble was placed in the tube and the cork was quickly replaced.
- A digital clock was started.
- When the gas collection tube was full, the clock was stopped.

experiment number	1	2	3	4
temperature /°C	24	37	49	62
time taken /s	148			22

Fig. 5.2

- (a) (i) Name two more pieces of apparatus, not shown in Fig. 5.1, that the student will need for these experiments.

1.

2.

[2]

- (ii) What must the gas collection tube be filled with, before each experiment begins?

..... [1]

- (iii) Name the gas that was collected.

..... [1]



Fig. 5.3

(b) Read the digital clocks shown in Fig. 5.3, for the missing times, and record them in Fig. 5.2. [2]

(c) Suggest **one** change to the method to improve the accuracy of the experiment.

.....
 [1]

(d) Use the information in Fig. 5.2 to show how the speed of reaction is affected by change of temperature.

.....

 [2]

(e) Explain your answer in (d) in terms of the behaviour of the reacting particles.

.....

 [1]

6 An experiment was done to investigate the thermal conductivity of five different metals.

- A student took a 20 cm long bar of metal and heated one end. Then he hammered the end until there was a dent in it. This is shown in Fig. 6.1.
- He dripped wax from a lit candle into the dent and then placed a small glass bead in the wax. When the metal bar was cold the wax became solid and the glass bead was stuck to the bar.
- He rested the cold bar on a tripod, shown in Fig. 6.2, so that the glass bead was underneath the bar.
- He started a stop clock and heated the other end of the bar using a moderately hot flame.
- When the wax melted and the glass bead dropped off, he stopped the clock. He recorded the time taken for the wax to melt in Fig. 6.3.

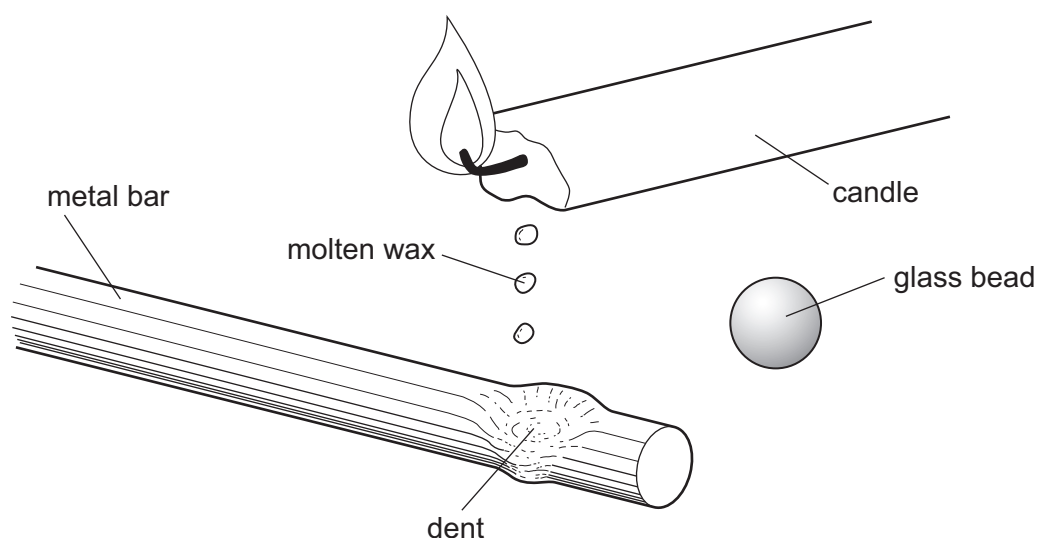

Fig. 6.1

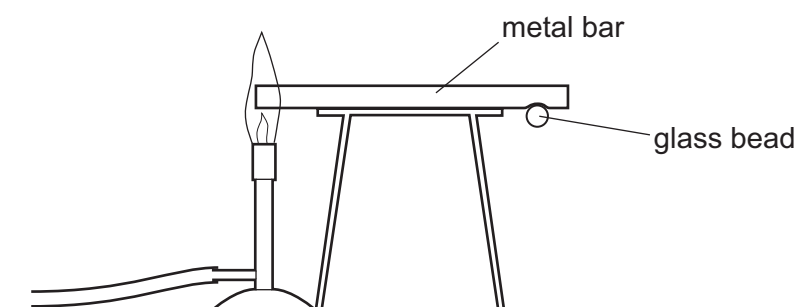

Fig. 6.2

metal	copper	iron	steel	aluminium	nickel
time taken for the wax to melt/s	26	130	190		

Fig. 6.3



Fig. 6.4

(a) Read the digital timers in Fig. 6.4 and record the results for the metals aluminium and nickel in Fig. 6.3. [2]

(b) (i) What physical property enabled the student to make a dent in the hot bar?
..... [1]

(ii) Suggest which of the metals was hardest to dent. Explain why you chose this metal.
metal
explanation
..... [2]

(c) What type of substance is candle wax? Name the main source of candle wax.
type of substance
source [2]

(d) The student wanted to carry out this experiment with a bar of magnesium. Suggest why the teacher did not allow him to do this.
.....
..... [1]

(e) Suggest **one** way to make this experiment a fairer test.

.....
..... [1]

(f) The student did the experiment with a 20 cm glass bar. The wax did not melt and the glass bead did not fall off.
Explain the difference in the properties of metal and glass that is shown by this experiment.

.....
.....
..... [1]

BLANK PAGE

Permission to reproduce items where third-party owned material protected by copyright is included has been sought and cleared where possible. Every reasonable effort has been made by the publisher (UCLES) to trace copyright holders, but if any items requiring clearance have unwittingly been included, the publisher will be pleased to make amends at the earliest possible opportunity.

University of Cambridge International Examinations is part of the Cambridge Assessment Group. Cambridge Assessment is the brand name of University of Cambridge Local Examinations Syndicate (UCLES), which is itself a department of the University of Cambridge.