

UNIVERSITY OF CAMBRIDGE INTERNATIONAL EXAMINATIONS  
International General Certificate of Secondary Education

**CO-ORDINATED SCIENCES**

**0654/01**

Paper 1 Multiple Choice

October/November 2006

**45 minutes**

Additional Materials: Multiple Choice Answer Sheet  
Soft clean eraser  
Soft pencil (type B or HB is recommended)

**READ THESE INSTRUCTIONS FIRST**

Write in soft pencil.

Do not use staples, paper clips, highlighters, glue or correction fluid.

Write your name, Centre number and candidate number on the Answer Sheet in the spaces provided unless this has been done for you.

There are **forty** questions on this paper. Answer **all** questions. For each question there are four possible answers **A, B, C** and **D**.

Choose the **one** you consider correct and record your choice in **soft pencil** on the separate Answer Sheet.

**Read the instructions on the Answer Sheet very carefully.**

Each correct answer will score one mark. A mark will not be deducted for a wrong answer.

Any rough working should be done in this booklet.

A copy of the Periodic Table is printed on page 20.

This document consists of **18** printed pages and **2** blank pages.



- 1 A fossil shows evidence of an organism with scaly skin, a tail and four legs.

In which group would the organism be classified?

- A amphibians
- B fish
- C mammals
- D reptiles

- 2 The diagram shows an incomplete plant cell.

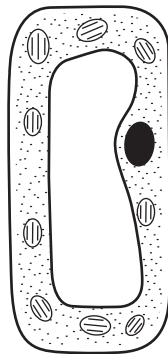

Which structure is **not** shown?

- A cell membrane
  - B cell wall
  - C chloroplast
  - D vacuole
- 3 Which two parts of the eye help to focus light rays?
- A cornea and iris
  - B cornea and lens
  - C iris and retina
  - D lens and retina

- 4 An experiment is set up as shown to investigate starch production in the leaves of a plant. After six hours in sunlight, leaf **Y** is tested for starch.

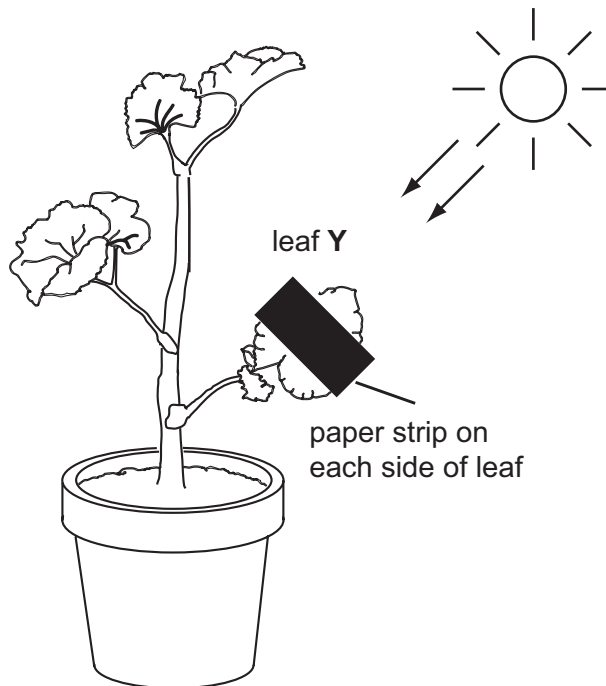

There is no starch produced under the paper strip because there was an absence of

- A carbon dioxide.
- B chlorophyll.
- C light.
- D oxygen.

- 5 Roots of a seedling are placed in a solution containing red dye.

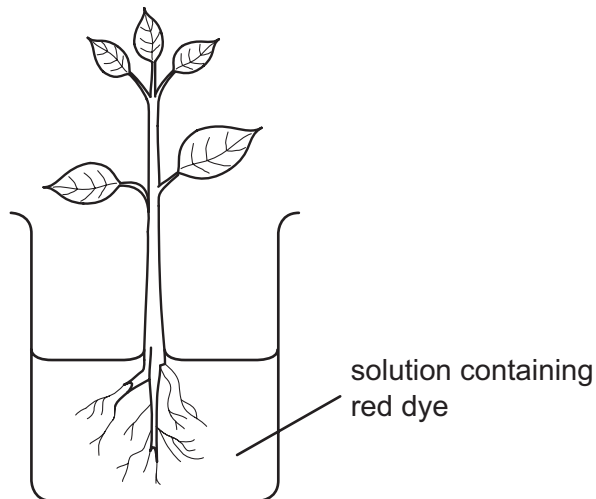

What is the path of the red dye after it has entered the roots?

- A phloem in root → phloem in stem
  - B phloem in root → xylem in stem
  - C xylem in root → phloem in stem
  - D xylem in root → xylem in stem
- 6 Which sequence shows the correct order of structures through which air passes when we breathe in?
- A alveolus → bronchiole → trachea → bronchus
  - B bronchus → trachea → alveolus → bronchiole
  - C bronchiole → alveolus → bronchus → trachea
  - D trachea → bronchus → bronchiole → alveolus

7 The table shows the amount of protein and fat in 100g samples of different foods.

foods	protein /g	fat /g
meat	18.0	17.0
bread	9.0	1.5
fish	18.0	0.5
eggs	13.0	11.0
potato chips	4.0	9.0

Which foods are best for body-building?

- A bread and meat
- B bread and potato chips
- C meat and eggs
- D meat and fish

8 Calcium and iron are components of the diet.

Which parts of the body need these components?

	dietary component	
	calcium	iron
A	blood	bone
B	blood	skin
C	bone	blood
D	skin	bone

9 The diagram shows how the eye and a muscle of a person are linked when responding to a change in the environment.

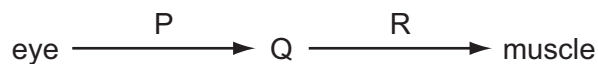

What do P, Q and R represent?

	P	Q	R
A	effector	stimulus	receptor
B	impulses	central nervous system	impulses
C	receptor	central nervous system	effector
D	stimulus	receptor	effector

10 The diagram shows the male reproductive system.

In which structure are hormones produced that control adolescence?

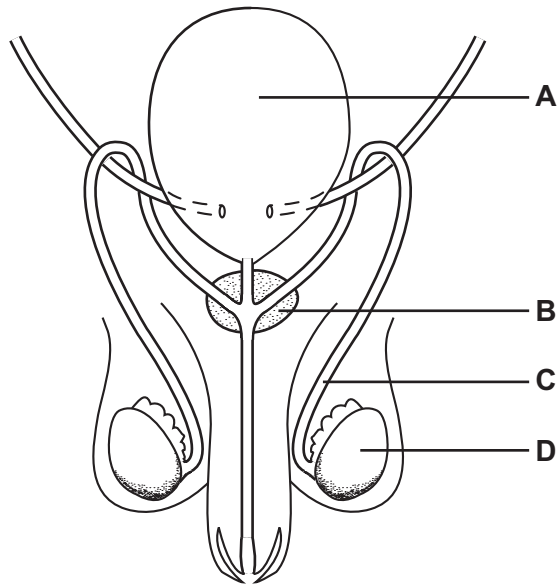

11 Cystic fibrosis is an inherited disease. The diagram shows the occurrence of this disease in a family.

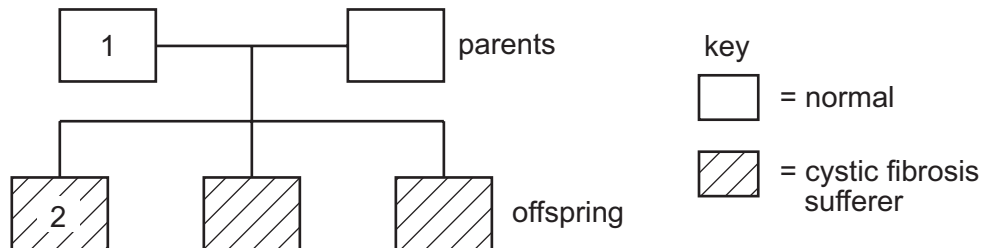

If B represents the normal allele and b the allele for cystic fibrosis, what are the genotypes for 1 and 2?

	individual 1	individual 2
<b>A</b>	bb	bb
<b>B</b>	Bb	bb
<b>C</b>	Bb	Bb
<b>D</b>	BB	Bb

12 Which process converts energy into a form that can be used by all living organisms?

- A** decomposition
- B** denitrification
- C** digestion
- D** photosynthesis

13 The diagram shows a simple carbon cycle.

Which line should have an arrow at both ends?

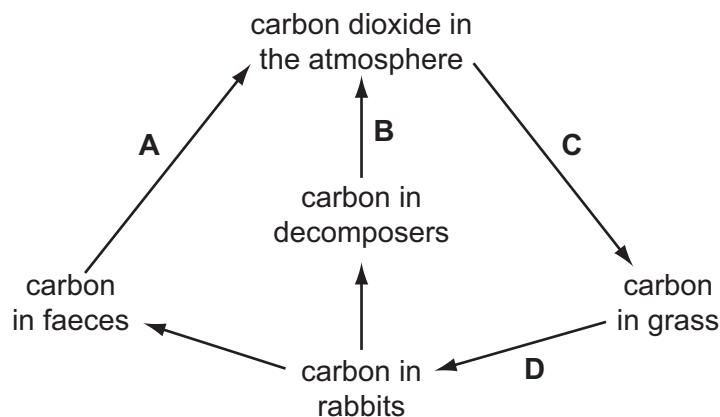

14 Which row in the table shows the relative charge of an electron and of a neutron?

	electron	neutron
<b>A</b>	+1	0
<b>B</b>	+1	-1
<b>C</b>	-1	0
<b>D</b>	-1	+1

15 An element is in Group VI of the Periodic Table.

What information does this give about the element?

- A** the number of protons in the nucleus
- B** the number of outer electrons
- C** the reactivity of the element
- D** the relative atomic mass of the element

16 Which process would show that crude oil is a mixture?

- A** combustion
- B** cracking
- C** fractional distillation
- D** neutralisation

17 Crude oil, salt and wood are important raw materials used in industry.

Which of these raw materials is used to make alkali, paper and plastics?

	alkali	paper	plastics
<b>A</b>	crude oil	wood	salt
<b>B</b>	salt	crude oil	wood
<b>C</b>	salt	wood	crude oil
<b>D</b>	wood	salt	crude oil

18 Which diagrams show a giant molecular structure?

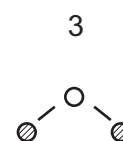
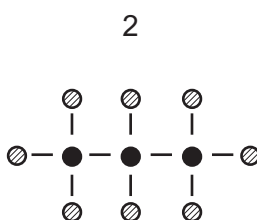
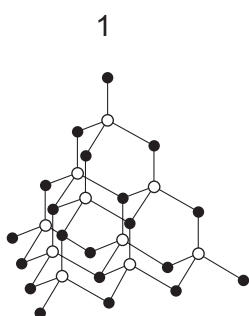

- A** 1 only  
**B** 2 only  
**C** 3 only  
**D** 1, 2 and 3



19 The diagram shows apparatus used for electrolysis.

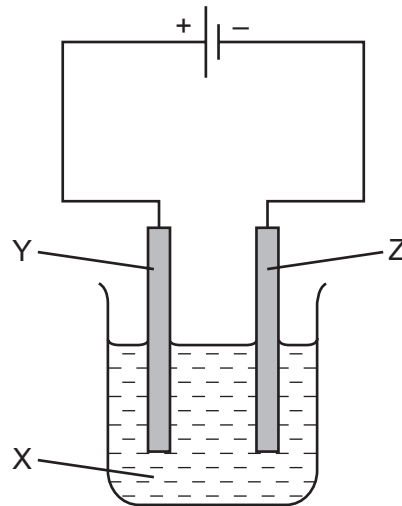

Which row shows the correct labelling for the apparatus?

	anode	cathode	electrolyte
<b>A</b>	X	Y	Z
<b>B</b>	X	Z	Y
<b>C</b>	Y	X	Z
<b>D</b>	Y	Z	X

20 When some hard water is boiled in a kettle, a white scale forms inside the kettle.

Which two of the following statements are correct?

- 1 The hard water contains dissolved calcium carbonate.
- 2 The hard water contains dissolved calcium hydrogencarbonate.
- 3 The white scale contains calcium carbonate.
- 4 The white scale contains calcium hydrogencarbonate.

- A** 1 and 3  
**B** 1 and 4  
**C** 2 and 3  
**D** 2 and 4

21 The diagram shows acid being added to an alkali until it is neutralised.

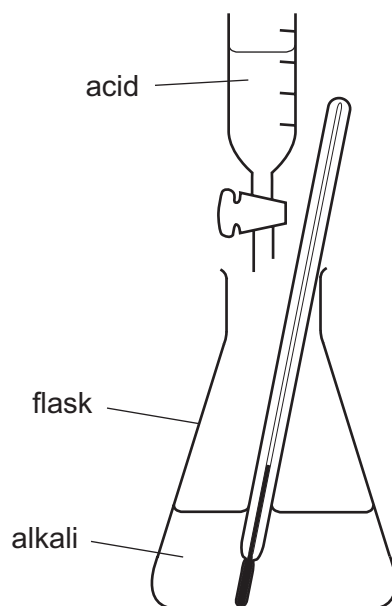

What happens in the flask?

	temperature	type of reaction
<b>A</b>	decreases	endothermic
<b>B</b>	decreases	exothermic
<b>C</b>	increases	endothermic
<b>D</b>	increases	exothermic

22 The diagram shows how limestone can be converted into useful products for industry.

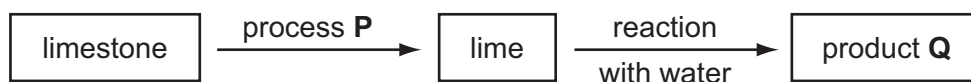

What are process **P** and product **Q**?

	<b>P</b>	<b>Q</b>
<b>A</b>	combustion	an acid
<b>B</b>	combustion	an alkali
<b>C</b>	decomposition	an acid
<b>D</b>	decomposition	an alkali

23 A small amount of ammonia is present in a sample of hydrogen.

What would be the results of tests on the mixture?

	damp blue litmus	lighted splint
<b>A</b>	stays blue	no effect
<b>B</b>	stays blue	pops
<b>C</b>	turns red	no effect
<b>D</b>	turns red	pops

24 A medicine contains two liquids that do not normally mix. Adding a small amount of liquid **X** helps to make the liquids mix.

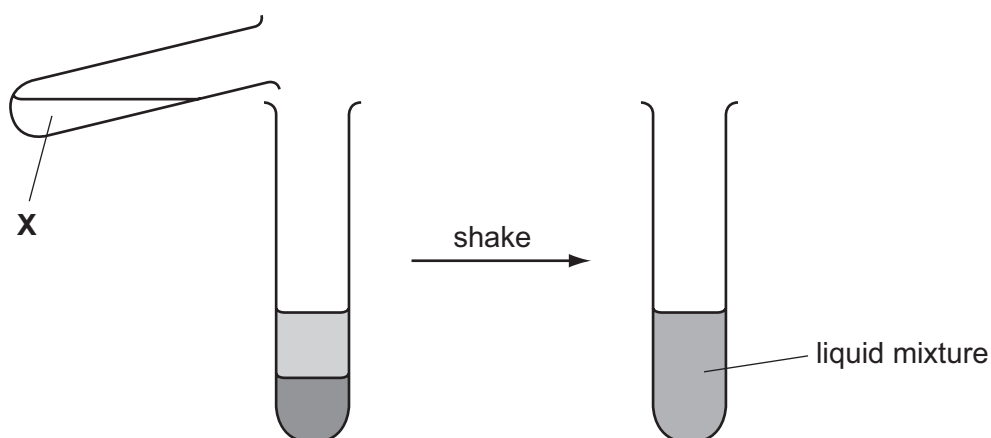

Which word best describes liquid **X**?

- A** analgesic
  - B** antacid
  - C** catalyst
  - D** emulsifier
- 25 Water is used to put out forest fires by spraying it on to the fire from aeroplanes.

Why is water used for this purpose?

- A** Water boils at 100 °C.
- B** Water cools the fire.
- C** Water is a good solvent.
- D** Water is a reducing agent.

- 26 In the simple cell shown, magnesium dissolves from the magnesium electrode and copper is deposited on the copper electrode.

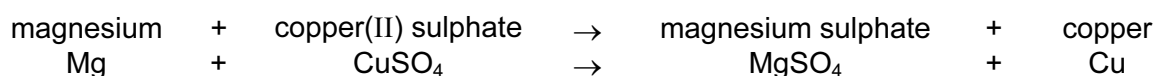
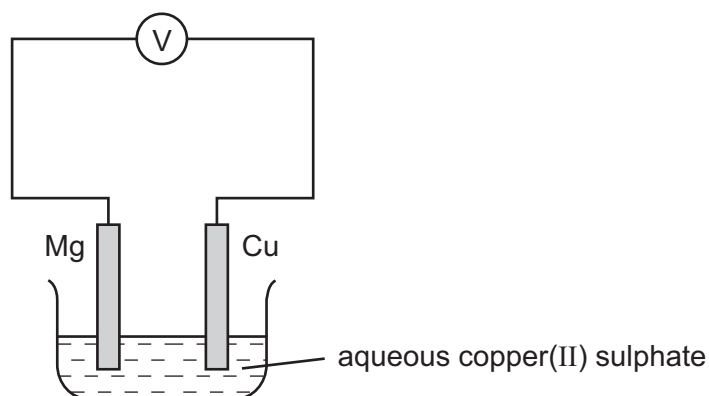

It can be deduced that magnesium is ....1.... reactive than copper and that the mass of the deposited copper is ....2.... the mass of the dissolved magnesium.

Which words correctly complete gaps 1 and 2?

	gap 1	gap 2
<b>A</b>	less	more than
<b>B</b>	less	the same as
<b>C</b>	more	more than
<b>D</b>	more	the same as

- 27 Substance **R** has a high melting point and reacts with an acid to produce hydrogen.

What does this show about substance **R**?

	metal or non-metal	structure
<b>A</b>	metal	giant
<b>B</b>	metal	molecular
<b>C</b>	non-metal	giant
<b>D</b>	non-metal	molecular

28 A ruler is used to measure the length of a nail.

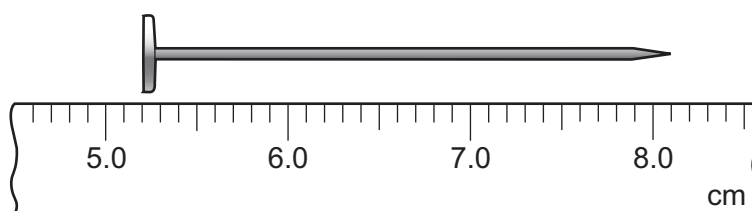

What is the length of the nail?

- A** 1.3 cm      **B** 2.9 cm      **C** 5.2 cm      **D** 8.1 cm

29 A newton is a unit of force.

Which quantity is measured in newtons?

- A** acceleration  
**B** density  
**C** mass  
**D** weight

30 A student pours liquid into a measuring cylinder.

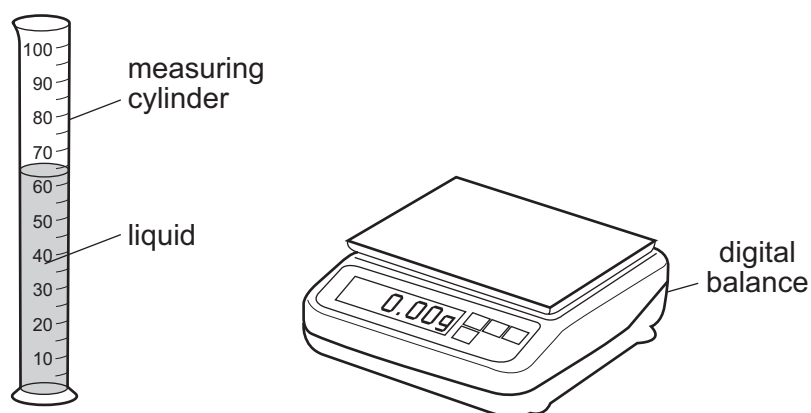

The student records the volume of the liquid from the scale on the measuring cylinder. He then puts the measuring cylinder containing the liquid on a balance and records the mass.

What else needs to be measured before the density of the liquid can be calculated?

- A** the depth of the liquid in the measuring cylinder  
**B** the mass of the empty measuring cylinder  
**C** the temperature of the liquid in the measuring cylinder  
**D** the volume of the empty measuring cylinder

31 Which source of energy uses the production of steam to generate electricity?

- A hydroelectric
- B nuclear
- C tides
- D waves

32 A cyclist travels down a hill from rest at point X without pedalling.

The cyclist applies his brakes and the cycle stops at point Y.



Which energy changes have taken place between X and Y?

- A kinetic  $\rightarrow$  internal (heat)  $\rightarrow$  gravitational potential
- B kinetic  $\rightarrow$  gravitational potential  $\rightarrow$  internal (heat)
- C gravitational potential  $\rightarrow$  internal (heat)  $\rightarrow$  kinetic
- D gravitational potential  $\rightarrow$  kinetic  $\rightarrow$  internal (heat)

33 To prevent a cement mixer sinking into soft ground, the mixer is placed on a large flat board.

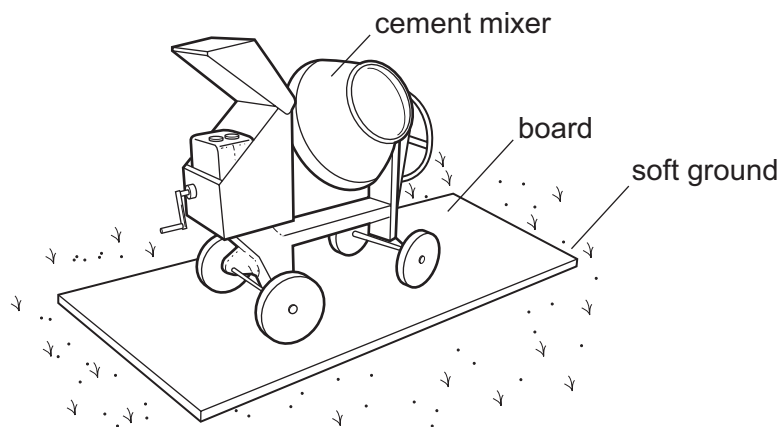

Why does this prevent the mixer sinking?

- A The large area decreases the pressure on the ground.
- B The large area increases the pressure on the ground.
- C The large area decreases the weight on the ground.
- D The large area increases the weight on the ground.

34 Which line in the table is correct about conduction and convection?

	conduction	convection
<b>A</b>	can happen in a solid	can happen in a solid
<b>B</b>	can happen in a solid	only happens in fluids
<b>C</b>	only happens in fluids	can happen in a solid
<b>D</b>	only happens in fluids	only happens in fluids

35 The diagram shows a ray of light striking a plane mirror.

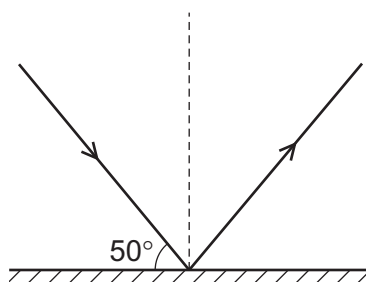

What is the angle of reflection?

- A**  $40^\circ$                       **B**  $50^\circ$                       **C**  $80^\circ$                       **D**  $130^\circ$

36 A student wishes to measure the electromotive force (e.m.f.) of a battery and the potential difference (p.d.) across a resistor.

She has the resistor, the battery and some connecting wires.

What else does she need?

- A** a voltmeter only  
**B** an ammeter only  
**C** an ammeter and a voltmeter  
**D** a force meter (newton meter) and a voltmeter

37 In the circuit below, one of the lamps breaks, causing all the other lamps to go out.

Which lamp breaks?

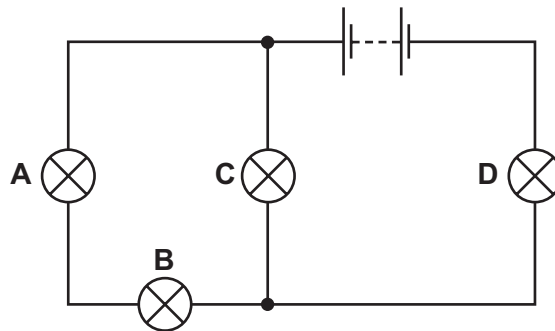

38 An electric heater is connected to the mains, using insulated copper wires. The wires become very warm.

What can be done to prevent so much heat being produced in the connecting wires?

- A Use thicker copper wires.
- B Use thinner copper wires.
- C Use thicker insulation.
- D Use thinner insulation.

39 Particles are emitted by a heated cathode in a cathode-ray tube.

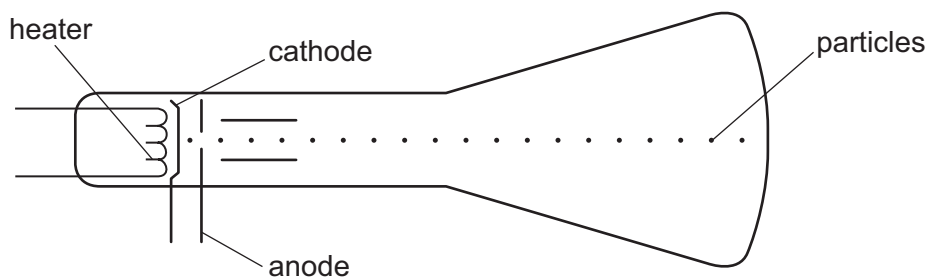

What are these particles?

- A atoms
- B electrons
- C neutrons
- D protons



40 Which line in the table describes the nature of alpha radiation and of gamma radiation?

	alpha radiation	gamma radiation
<b>A</b>	helium nuclei	electromagnetic waves
<b>B</b>	helium nuclei	electrons
<b>C</b>	protons	electromagnetic waves
<b>D</b>	protons	electrons



**BLANK PAGE**

**DATA SHEET**  
The Periodic Table of the Elements

			Group						
I	II	III	IV	V	VI	VII	0		
		<b>1</b> H Hydrogen 1					<b>4</b> He Helium 2		
<b>7</b> Li Lithium 3	<b>9</b> Be Beryllium 4	<b>11</b> B Boron 5	<b>12</b> C Carbon 6	<b>14</b> N Nitrogen 7	<b>16</b> O Oxygen 8	<b>19</b> F Fluorine 9	<b>20</b> Ne Neon 10		
<b>23</b> Na Sodium 11	<b>24</b> Mg Magnesium 12	<b>27</b> Al Aluminium 13	<b>28</b> Si Silicon 14	<b>31</b> P Phosphorus 15	<b>32</b> S Sulphur 16	<b>35.5</b> Cl Chlorine 17	<b>40</b> Ar Argon 18		
<b>39</b> K Potassium 19	<b>40</b> Ca Calcium 20	<b>48</b> Ti Titanium 22	<b>51</b> V Vanadium 23	<b>55</b> Mn Manganese 25	<b>56</b> Fe Iron 26	<b>59</b> Ni Nickel 28	<b>64</b> Cu Copper 29		
<b>85</b> Rb Rubidium 37	<b>88</b> Sr Strontium 38	<b>91</b> Zr Zirconium 40	<b>93</b> Nb Niobium 41	<b>96</b> Mo Molybdenum 42	<b>101</b> Ru Ruthenium 44	<b>106</b> Pd Palladium 46	<b>108</b> Ag Silver 47		
<b>133</b> Cs Caesium 55	<b>137</b> Ba Barium 56	<b>178</b> Hf Hafnium 72	<b>181</b> Ta Tantalum 73	<b>184</b> W Tungsten 74	<b>190</b> Os Osmium 76	<b>195</b> Pt Platinum 78	<b>197</b> Au Gold 79		
<b>Fr</b> Francium 87	<b>Ra</b> Radium 88	<b>Sc</b> Scandium 21	<b>Y</b> Yttrium 39	<b>Re</b> Rhenium 75	<b>Ir</b> Iridium 77	<b>Pt</b> Platinum 78	<b>Hg</b> Mercury 80		
		<b>Ca</b> Calcium 20	<b>Nb</b> Niobium 41	<b>Rh</b> Rhodium 45	<b>Ru</b> Ruthenium 44	<b>Cd</b> Cadmium 48	<b>Sn</b> Tin 50		
		<b>La</b> Lanthanum 57	<b>Tc</b> Technetium 43	<b>Co</b> Cobalt 27	<b>Ga</b> Gallium 31	<b>Zn</b> Zinc 30	<b>Ge</b> Germanium 32		
		<b>Ac</b> Actinium 89	<b>Pt</b> Platinum 78	<b>Pd</b> Palladium 46	<b>In</b> Indium 49	<b>Hg</b> Mercury 80	<b>Pb</b> Lead 82		
			<b>Os</b> Osmium 76	<b>Ni</b> Nickel 28	<b>Sn</b> Tin 50	<b>Pb</b> Lead 82	<b>Bi</b> Bismuth 83		
			<b>Ir</b> Iridium 77	<b>Cu</b> Copper 29	<b>Te</b> Tellurium 52	<b>Po</b> Polonium 84	<b>At</b> Astatine 85		
			<b>Rh</b> Rhodium 45	<b>Ni</b> Nickel 28	<b>At</b> Astatine 85	<b>At</b> Astatine 85	<b>At</b> Astatine 85		
			<b>Pd</b> Palladium 46	<b>Cu</b> Copper 29	<b>At</b> Astatine 85	<b>At</b> Astatine 85	<b>At</b> Astatine 85		
			<b>Pt</b> Platinum 78	<b>Cu</b> Copper 29	<b>At</b> Astatine 85	<b>At</b> Astatine 85	<b>At</b> Astatine 85		

\*58-71 Lanthanoid series  
†90-103 Actinoid series

a	<b>X</b>
b	

Key

a = relative atomic mass  
X = atomic symbol  
b = proton (atomic) number

	<b>159</b> Tb Terbium 65	<b>157</b> Gd Gadolinium 64	<b>152</b> Eu Europium 63	<b>150</b> Sm Samarium 62	<b>144</b> Nd Neodymium 60	<b>141</b> Pr Praseodymium 59	<b>140</b> Ce Cerium 58
	<b>162</b> Dy Dysprosium 66	<b>162</b> Dy Dysprosium 66	<b>162</b> Dy Dysprosium 66	<b>162</b> Dy Dysprosium 66	<b>162</b> Dy Dysprosium 66	<b>162</b> Dy Dysprosium 66	<b>162</b> Dy Dysprosium 66
	<b>167</b> Er Erbium 68	<b>167</b> Er Erbium 68	<b>167</b> Er Erbium 68	<b>167</b> Er Erbium 68	<b>167</b> Er Erbium 68	<b>167</b> Er Erbium 68	<b>167</b> Er Erbium 68
	<b>169</b> Tm Thulium 69	<b>169</b> Tm Thulium 69	<b>169</b> Tm Thulium 69	<b>169</b> Tm Thulium 69	<b>169</b> Tm Thulium 69	<b>169</b> Tm Thulium 69	<b>169</b> Tm Thulium 69
	<b>173</b> Yb Ytterbium 70	<b>173</b> Yb Ytterbium 70	<b>173</b> Yb Ytterbium 70	<b>173</b> Yb Ytterbium 70	<b>173</b> Yb Ytterbium 70	<b>173</b> Yb Ytterbium 70	<b>173</b> Yb Ytterbium 70
	<b>175</b> Lu Lutetium 71	<b>175</b> Lu Lutetium 71	<b>175</b> Lu Lutetium 71	<b>175</b> Lu Lutetium 71	<b>175</b> Lu Lutetium 71	<b>175</b> Lu Lutetium 71	<b>175</b> Lu Lutetium 71
	<b>101</b> Md Mendelevium 101	<b>101</b> Md Mendelevium 101	<b>101</b> Md Mendelevium 101	<b>101</b> Md Mendelevium 101	<b>101</b> Md Mendelevium 101	<b>101</b> Md Mendelevium 101	<b>101</b> Md Mendelevium 101
	<b>100</b> Fm Fermium 100	<b>100</b> Fm Fermium 100	<b>100</b> Fm Fermium 100	<b>100</b> Fm Fermium 100	<b>100</b> Fm Fermium 100	<b>100</b> Fm Fermium 100	<b>100</b> Fm Fermium 100
	<b>102</b> No Nobelium 102	<b>102</b> No Nobelium 102	<b>102</b> No Nobelium 102	<b>102</b> No Nobelium 102	<b>102</b> No Nobelium 102	<b>102</b> No Nobelium 102	<b>102</b> No Nobelium 102
	<b>103</b> Lr Lawrencium 103	<b>103</b> Lr Lawrencium 103	<b>103</b> Lr Lawrencium 103	<b>103</b> Lr Lawrencium 103	<b>103</b> Lr Lawrencium 103	<b>103</b> Lr Lawrencium 103	<b>103</b> Lr Lawrencium 103

The volume of one mole of any gas is 24 dm<sup>3</sup> at room temperature and pressure (r.t.p.).