

Candidate Name _____

Centre Number	Candidate Number

**International General Certificate of Secondary Education
CAMBRIDGE INTERNATIONAL EXAMINATIONS**

**COMBINED SCIENCE
CO-ORDINATED SCIENCES
PAPER 6 Alternative to Practical**

**0653/6
0654/6**

MAY/JUNE SESSION 2002

1 hour

Candidates answer on the question paper.
No additional materials are required.

TIME 1 hour

INSTRUCTIONS TO CANDIDATES

Write your name, Centre number and candidate number in the spaces at the top of this page.

Answer **all** questions.

Write your answers in the spaces provided on the question paper.

INFORMATION FOR CANDIDATES

The number of marks is given in brackets [] at the end of each question or part question.

FOR EXAMINER'S USE	
1	
2	
3	
4	
5	
6	
TOTAL	

This question paper consists of 16 printed pages.



- 1 Catalase is an enzyme produced by potato cells. It catalyses the breakdown of hydrogen peroxide into oxygen and water. When a potato is cut, catalase is released by the damaged cells.

A student did an experiment to investigate the effect of surface area of potato on the activity of catalase.

- She prepared several identical pieces of potato.
- Then she put 10 cm³ of hydrogen peroxide and two drops of liquid detergent into a test-tube.
- She dropped one piece of potato into the tube and waited for 2 minutes. During this time bubbles of oxygen were released which produced a foam, as shown in Fig. 1.1.

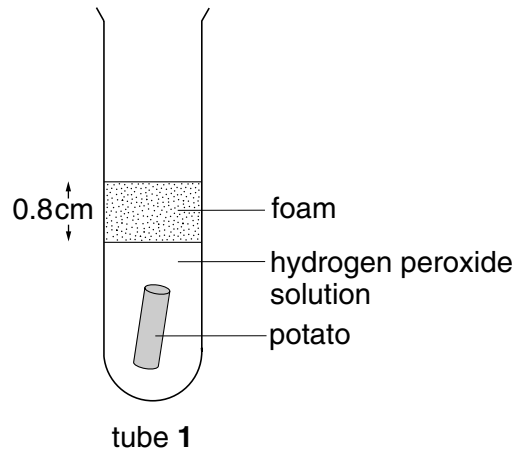

Fig. 1.1

- She measured the height of the foam using a ruler, and recorded it in the table.
- She repeated the experiment. The surface area of the potato used was increased by cutting it into two parts.
- She did the experiment three more times, cutting the potato into three, then four, and five parts. Each time she measured the height of the foam (see Fig. 1.2).

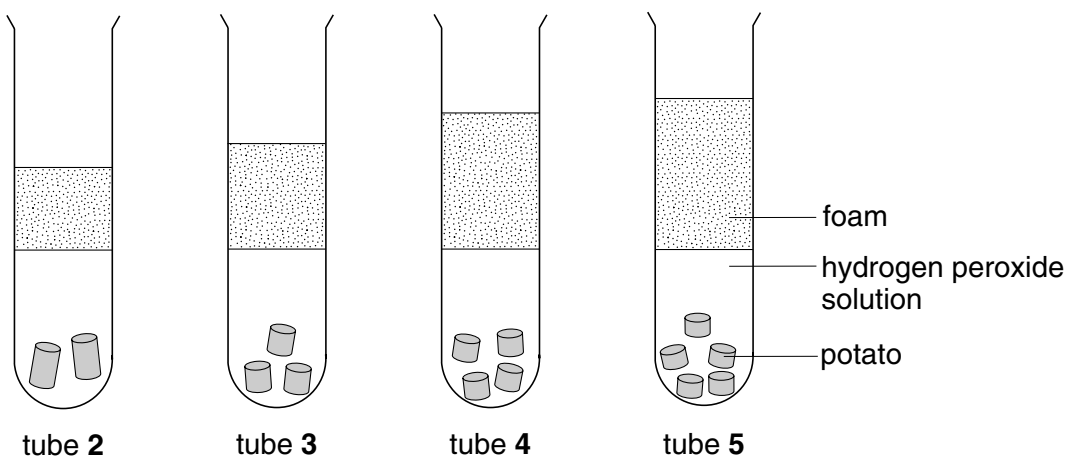

Fig. 1.2

- (a) Measure the height of the foam in each of the tubes above and record your results in Fig. 1.3.

tube number	surface area of potato/cm ²	height of foam/cm
1	5.0	0.8
2	7.0	
3	9.0	
4	11.0	
5	13.0	

[4]

Fig. 1.3

- (b) (i) On the grid provided plot a graph of height of foam against surface area of potato and draw a suitable line through the points.

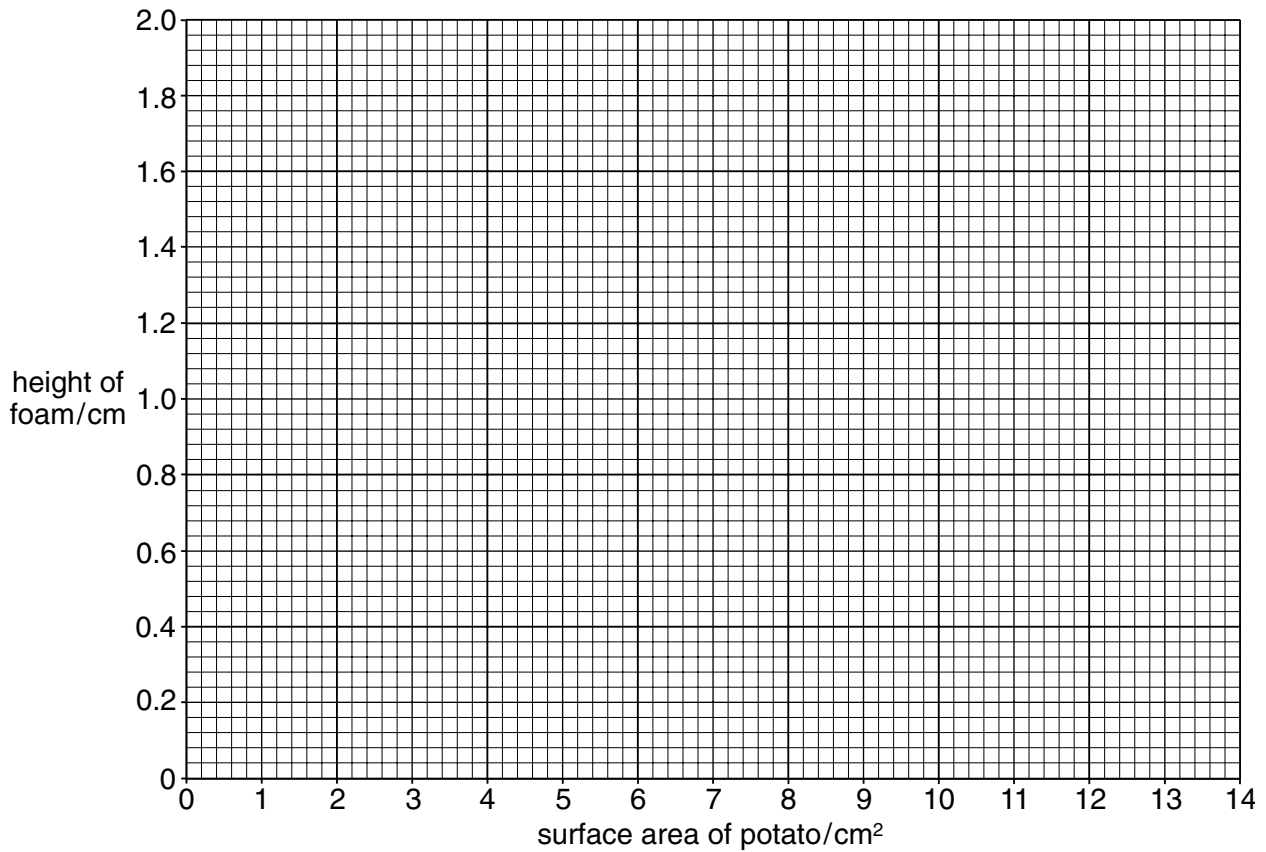

[3]

(ii) What does the graph show about the effect of surface area on the activity of catalase?

.....
.....
.....[2]

(iii) The height of foam increases, and more oxygen is produced, when the potato is cut into more pieces. Explain why this happens.

.....
.....[1]

2 A balance was made using a metre rule. The student hung it at the 50 cm mark. The rule was free to swing and was balanced when it was horizontal.

- (a) A 40 g mass was placed on the 10 cm mark of the rule. A load, l , was placed on the 90 cm mark. The rule stayed in the horizontal position. This is shown in Fig. 2.1.

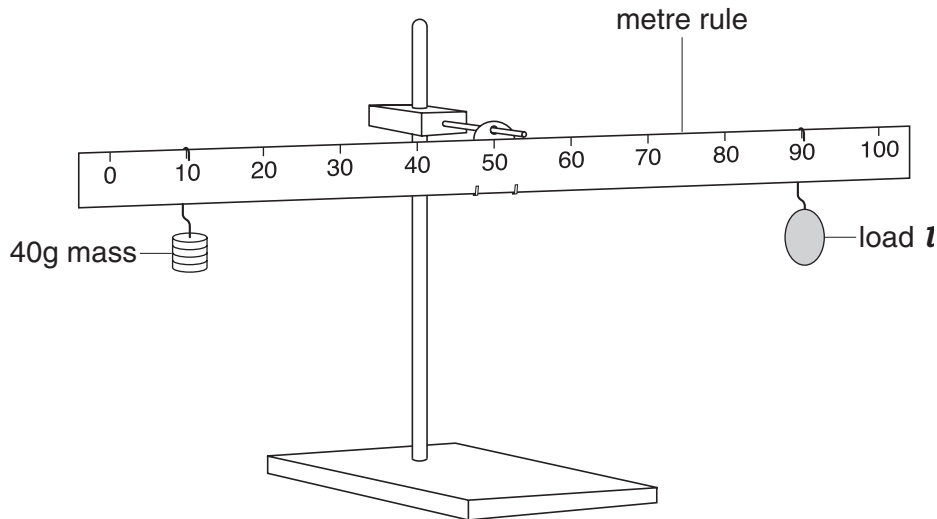

Fig. 2.1

- (i) Calculate the distance d_1 , from the 40 g mass to the 50 cm mark.

$$d_1 = \dots\dots\dots\text{cm [1]}$$

- (ii) Calculate the distance d_2 from the load l to the 50 cm mark.

$$d_2 = \dots\dots\dots\text{cm [1]}$$

The rule stayed in the horizontal position.

- (iii) What was the mass of the load, l ?

$$l = \dots\dots\dots\text{g [1]}$$

- (b) The student was told to use the apparatus to find the mass of another load m , which was heavier than load l .

He made the metre rule balance by putting the 40 g mass and the load m in the places shown in the diagram, Fig. 2.2.

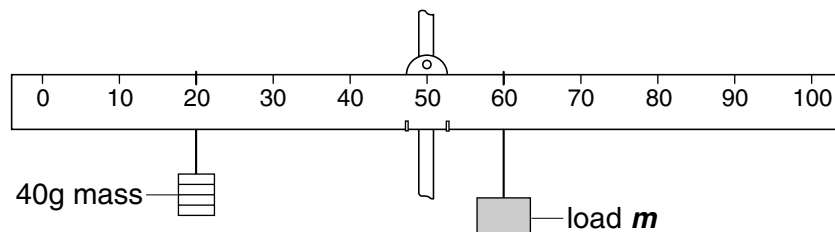

Fig. 2.2

- (i) Calculate the mass of the load m .

$m = \dots\dots\dots$ g [3]

- (ii) The load, m , was a cube of metal. The actual size of the cube is shown in Fig. 2.3. Measure one side of the cube and calculate its volume in cm^3 .

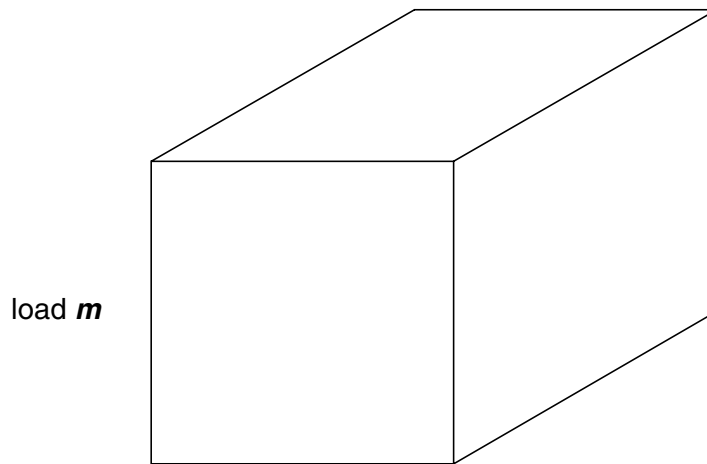

Fig. 2.3

length of one side of the cube = $\dots\dots\dots$ cm [1]

volume of the cube = $\dots\dots\dots$ cm^3 [1]

- (c) The student left the cube and the 40 g mass hanging on the rule. He hung the cube in a beaker of water. Then he moved the 40 g mass so that the rule would balance.

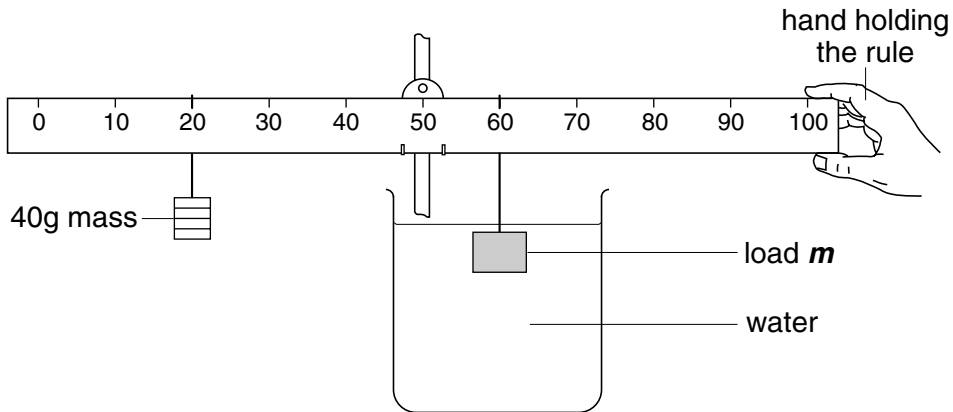

Fig. 2.4

- (i) On Fig. 2.4, draw an arrow to show which way he moved the 40 g mass to make the rule balance again. [1]
- (ii) Explain how you decided which way to draw the arrow.

.....

.....[1]

- 3 A student carried out tests on two white powders, potassium carbonate and potassium hydrogencarbonate. He recorded the results in the table, Fig. 3.1. Study the table and answer the questions which follow.

test	result for potassium carbonate	result for potassium hydrogencarbonate
1 (a) Add a portion of the powder to cold water and shake. (b) Add a portion of the powder to hot water and shake.	<i>a colourless liquid</i> <i>a colourless liquid</i>	<i>white powder below a colourless liquid</i> <i>a colourless liquid</i>
2 (a) Add a few drops of Universal Indicator to some of the solution from 1 (b) . (b) Boil the mixture from 2 (a) .	<i>dark blue</i> <i>stays dark blue</i>	<i>green/blue</i> <i>gradually turns dark blue</i>
3 (a) Heat a portion of the dry white powder. (b) Test the gas from 3 (a) with limewater. (c) Dissolve the residue from 3 (a) in water, add solid ammonium chloride and heat the mixture.	<i>stays white, no gas given off</i> <i>no reaction (no gas)</i> <i>a gas is given off which has a pungent smell and turns damp red litmus blue</i>	<i>stays white, a gas is given off</i> <i>limewater turns milky</i> <i>a gas is given off which has a pungent smell and turns damp red litmus blue</i>
4 (a) Add dilute nitric acid to some of the solution from 1 (b) . (b) Add aqueous barium nitrate to the mixture from 4 (a) .	<i>bubbles of a gas are given off</i> <i>a colourless solution</i>	<i>bubbles of a gas are given off</i> <i>a colourless solution</i>

Fig. 3.1

- (a) Which is more soluble in water, potassium carbonate or potassium hydrogencarbonate? Explain your answer.

.....
[1]

(b) (i) Suggest the pH value of potassium carbonate solution.

.....[1]

(ii) What happens to the pH value when potassium hydrogencarbonate solution is boiled?

.....[1]

(c) Name the gas given off when potassium hydrogencarbonate is heated.

.....[1]

(d) Name the gas given off in test 3 (c).

..... [1]

(e) How do the two observations in tests 4 (a) and 4 (b) differ from the results of a test for a sulphate?

.....
.....[2]

(f) The reaction of potassium carbonate with hydrochloric acid is exothermic.
The reaction of potassium hydrogencarbonate with hydrochloric acid is endothermic.
Using this information, describe an experiment to decide if a sample of a white powder is potassium carbonate or potassium hydrogencarbonate.
Briefly describe what you would do and state what measurements you would make.

.....
.....
.....
.....[3]

4 A student did an experiment to investigate the effect of acid rain on the germination of seeds, and on the early growth of the seedlings. She prepared three dishes for the experiment. Throughout the experiment she kept all conditions the same, but she watered the dishes with different solutions as follows:

- dish **A** distilled (pure) water
- dish **B** weakly acid rain
- dish **C** strongly acid rain.

(a) Name **one** of the conditions that was the same for all three dishes.

.....[1]

(b) (i) The photographs in Fig. 4.1 (opposite) show each dish after four days. Construct a table in the space below and use it to describe the **germination** and **growth** of the seeds in each dish.

[4]

(ii) Using your observations, what conclusions can you make about the effect of acid rain on the seeds?

.....

.....

.....[2]

(c) Describe an experiment you could do to find out how the pH of acid rain affects the percentage germination of cress seeds.

.....

.....

.....

.....

.....

.....[3]

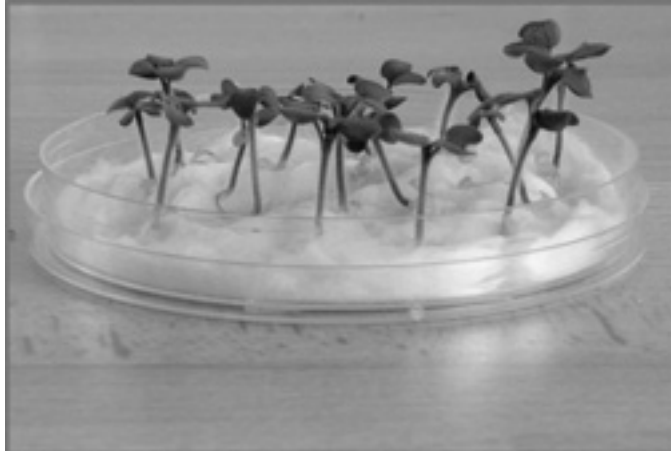

Dish A

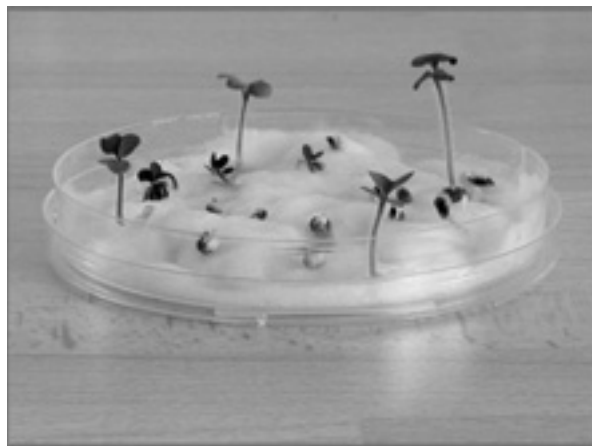

Dish B



Dish C

Fig. 4.1

- 5 A student wants to find out if flower petals contain one coloured substance or two. He follows the procedure shown in Fig. 5.1.

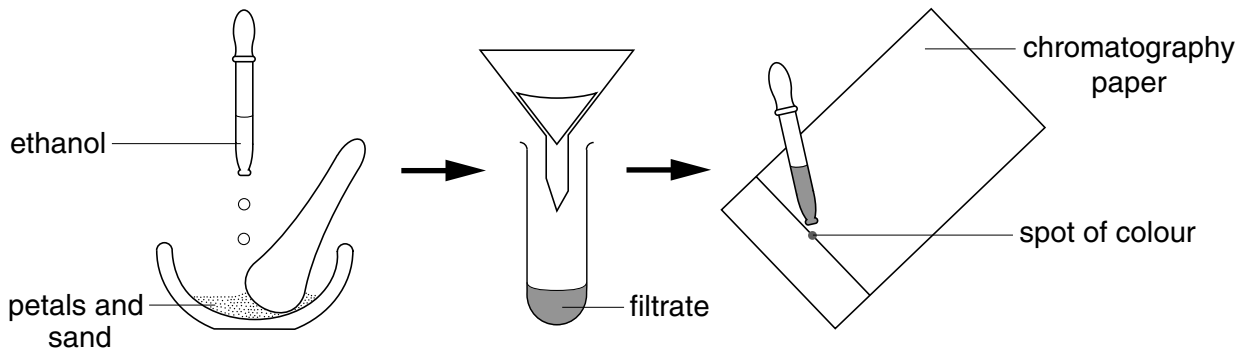

Fig. 5.1

- He grinds the petals with sand and adds a few cm³ of ethanol. The ethanol dissolves the coloured substance in the petal.
- He filters the mixture and collects the filtrate in a test-tube.
- He places a drop of the filtrate on a piece of chromatography paper and allows it to dry. He repeats this to make a spot of colour on the paper.

- (a) What is the advantage, to the flower, of coloured petals?

.....
[2]

- (b) Suggest a reason why ethanol is better than water for this experiment.

.....[1]

- (c) (i) The student uses the chromatography paper to find out if the colour contains one substance or two.
 Draw a diagram showing how he does this experiment.

[3]

- (ii) The student concludes that there are two substances in the petal colour. On the diagram, Fig.5.2, show what the chromatography paper looks like after the experiment.

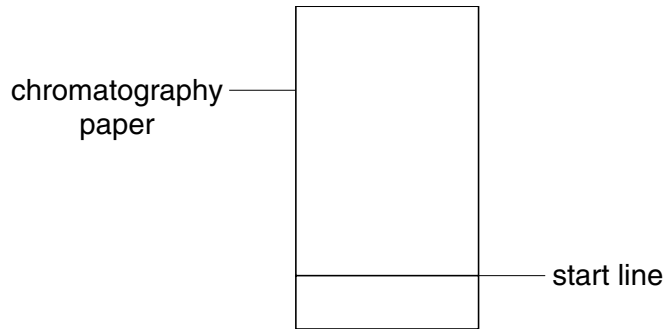

Fig. 5.2

[2]

- (d) Describe how the student can find out if the filtrate will act as an acid-base indicator.

.....

.....

.....[2]

- 6 A student investigated the way in which a current in a piece of wire varied with its length. He set up the circuit shown in Fig. 6.1.

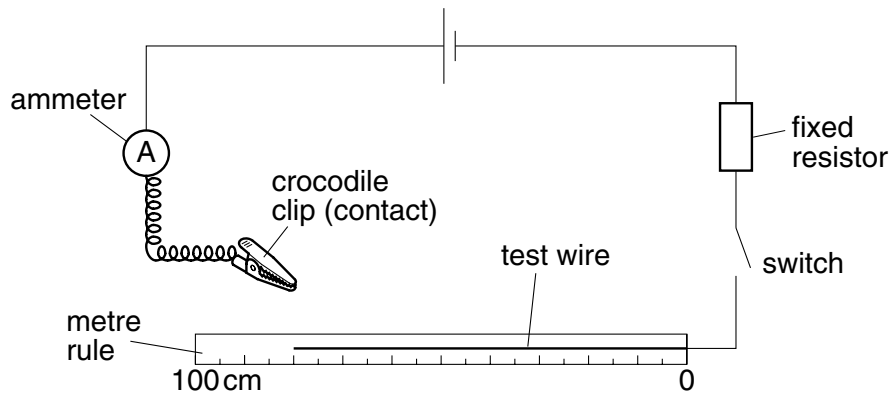

Fig. 6.1

- He closed the switch and touched the contact on the wire at the 100 mm (10 cm) mark.
- He read the ammeter and recorded the reading in Fig. 6.2.
- He repeated this procedure, touching the wire at the lengths shown in Fig. 6.2.

- (a) The ammeter scale for three of his readings is shown in Fig. 6.3. Record the readings in Fig. 6.2.

length of wire/mm	100	200	450	650	750
ammeter reading/mA	92				44

[3]

Fig. 6.2

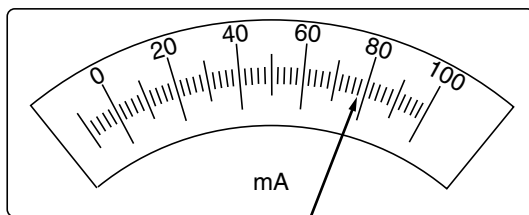

length of wire = 200mm

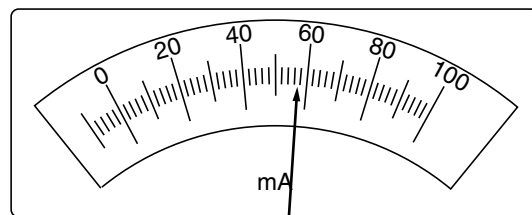

length of wire = 450mm

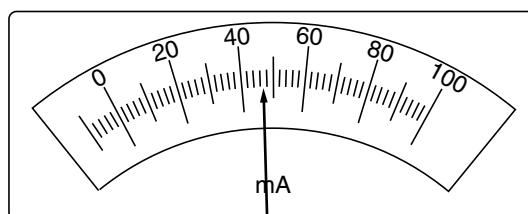

length of wire = 650mm

Fig. 6.3

- (b) Plot a graph of current, I , against length of wire, l , on the grid provided. Draw a suitable line through the points.

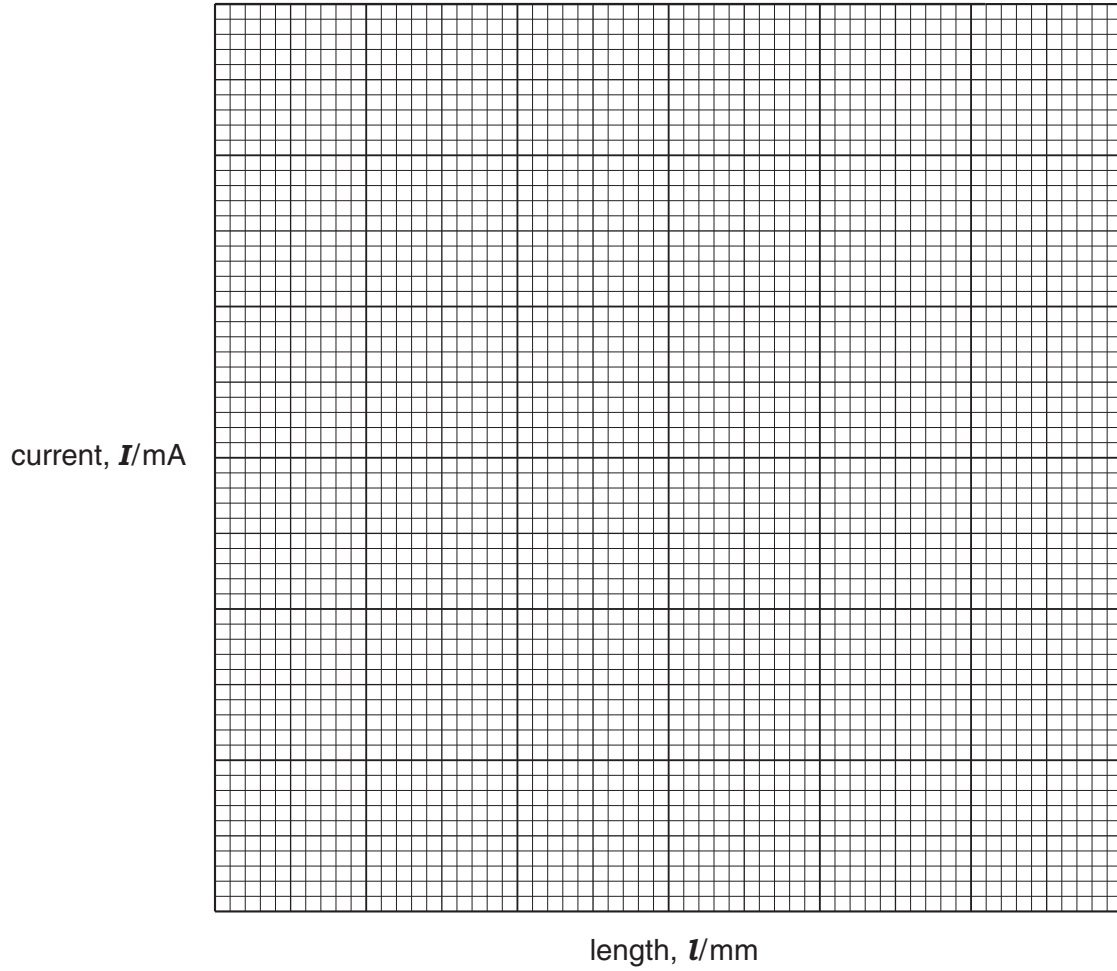

[2]

- (c) Use your graph to determine the current, I , flowing through an identical piece of wire of length 1000 mm.

.....[1]

- (d) Using the value of I from (c), calculate the resistance of 1000 mm of this wire using the formula

$$R = \frac{E}{I} \times 1000$$

E is the voltage of the cell used in the circuit, 1.5 V.

resistance of 1000 mm of wire = ohms

[1]

- (e) Ohm's Law states that the current through a wire is directly proportional to the voltage across its ends.
Briefly explain how you would carry out an experiment to verify Ohm's Law. Draw a diagram of the circuit you would use. Include in the circuit a variable resistor and a voltmeter.

.....

.....

.....

.....[3]