

CANDIDATE
NAME

--

CENTRE
NUMBER

--	--	--	--	--

CANDIDATE
NUMBER

--	--	--	--



COMBINED SCIENCE

0653/32

Paper 3 (Extended)

May/June 2016

1 hour 15 minutes

Candidates answer on the Question Paper.

No Additional Materials are required.

READ THESE INSTRUCTIONS FIRST

Write your Centre number, candidate number and name on all the work you hand in.

Write in dark blue or black pen.

You may use an HB pencil for any diagrams or graphs.

Do not use staples, paper clips, glue or correction fluid.

DO NOT WRITE IN ANY BARCODES.

Answer **all** questions.

Electronic calculators may be used.

You may lose marks if you do not show your working or if you do not use appropriate units.

A copy of the Periodic Table is printed on page 24.

At the end of the examination, fasten all your work securely together.

The number of marks is given in brackets [] at the end of each question or part question.

This document consists of **22** printed pages and **2** blank pages.

1 Fig. 1.1 shows some parts of the human alimentary canal and its associated organs.

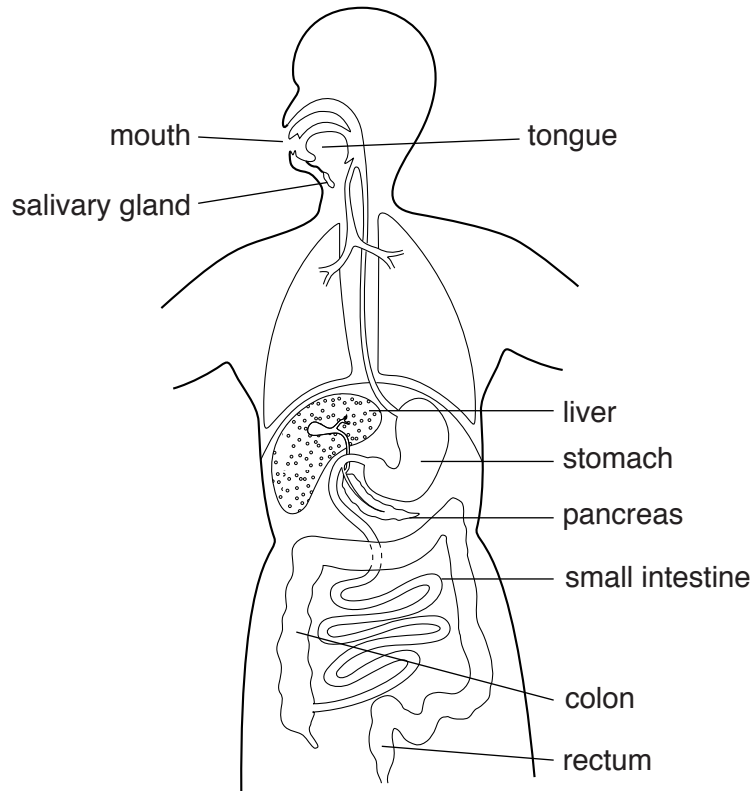

Fig. 1.1

(a) Use the labels in Fig. 1.1 to complete Table 1.1.

Table 1.1

function	name of organ(s)
ingestion
absorption of digested food
secrete digestive enzymes	stomach and and

[4]

- (b) The nutrients that have been absorbed from the digestive system travel in the blood to the body cells.

Fig. 1.2 shows a longitudinal section of a capillary next to some body cells.

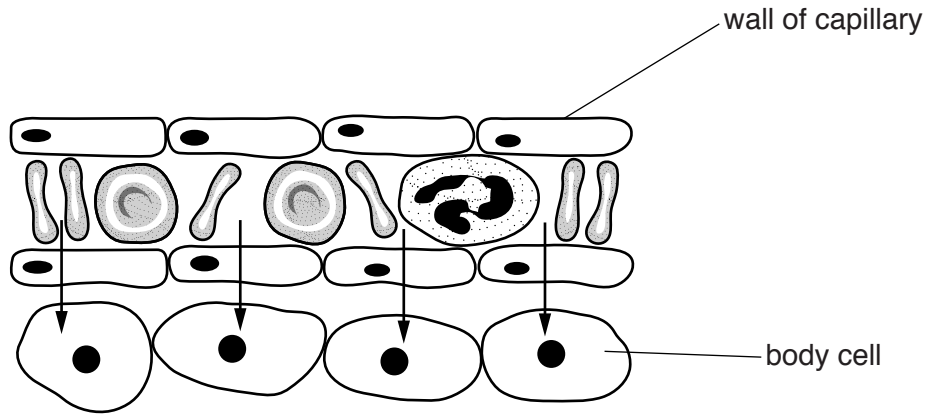

Fig. 1.2

The arrows show the direction of movement of glucose from the blood to the cells of the body.

Describe how the structure of the capillary allows this movement to take place effectively.

.....

.....

.....

..... [2]

- (c) Fig. 1.3 shows the effect of pH on the activity of an enzyme which is secreted into the food in the stomach. The environment in the stomach has a low pH because of the presence of hydrochloric acid.

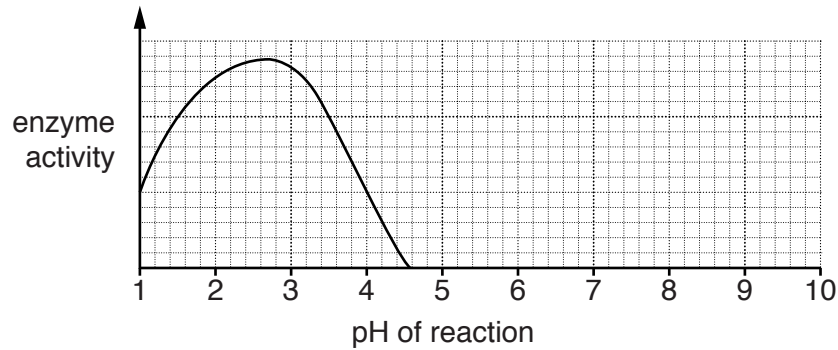

Fig. 1.3

- (i) State the optimum pH for this enzyme.

..... [1]

- (ii) The stomach contents enter the duodenum. The pH there is approximately 8.

Explain in detail why the enzyme shows no activity when it enters the duodenum.

.....

 [2]

- (iii) There are enzymes in the duodenum which digest the food after it has left the stomach.

On Fig. 1.3 draw a curve to suggest how the activity of an enzyme secreted into the duodenum varies with pH. [2]

Please turn over for Question 2

- 2 (a) Lead bromide, PbBr_2 , can be broken down into its elements using the apparatus shown in Fig. 2.1.

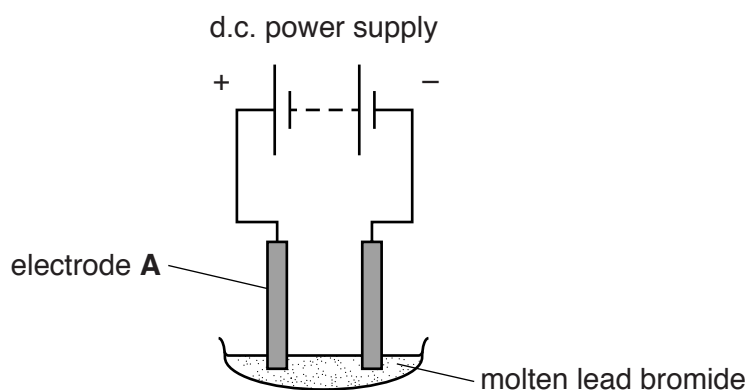

Fig. 2.1

- (i) Name the process shown in Fig. 2.1.

..... [1]

- (ii) Give the symbols of the ions present in molten lead bromide.

..... [1]

- (iii) Name the element produced at electrode **A** and state the colour of this element.

name

colour

[2]

- (b) In a similar process, aqueous copper chloride solution is broken down into a metal and chlorine gas.

- (i) Write the symbol equation for the reaction, including state symbols.

..... [2]

- (ii) Describe the chemical test for chlorine gas.

test

result

.....

[2]

- (c) (i) Describe the trend in the boiling points of the elements going down Group VII of the Periodic Table, from chlorine to iodine.

..... [1]

- (ii) Fluorine is another element in Group VII.

Use the Periodic Table to determine the electronic structure of an atom of fluorine.

..... [1]

- (iii) An atom of fluorine has a nucleon number of 19.

Calculate the number of neutrons in this atom.

number of neutrons = [1]

- 3 Fig. 3.1 shows a gravity racer. A gravity racer is a small cart with four wheels and no engine. It is steered by a driver as it runs down a sloping track.



Fig. 3.1

- (a) The mass of the cart and driver is 100 kg.

State the name given to the force on this mass due to the effect of gravity.

..... [1]

- (b) Fig. 3.2 shows the track becoming horizontal at the bottom of the slope.

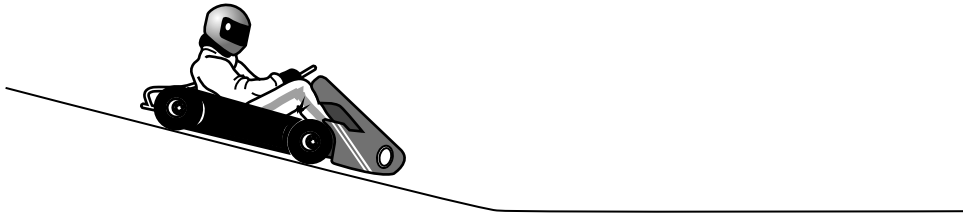

Fig. 3.2

The cart accelerates down the slope and then moves along the horizontal track for a distance before the driver applies the brakes and the cart stops.

Fig. 3.3 shows a speed/time graph for the motion of the cart.

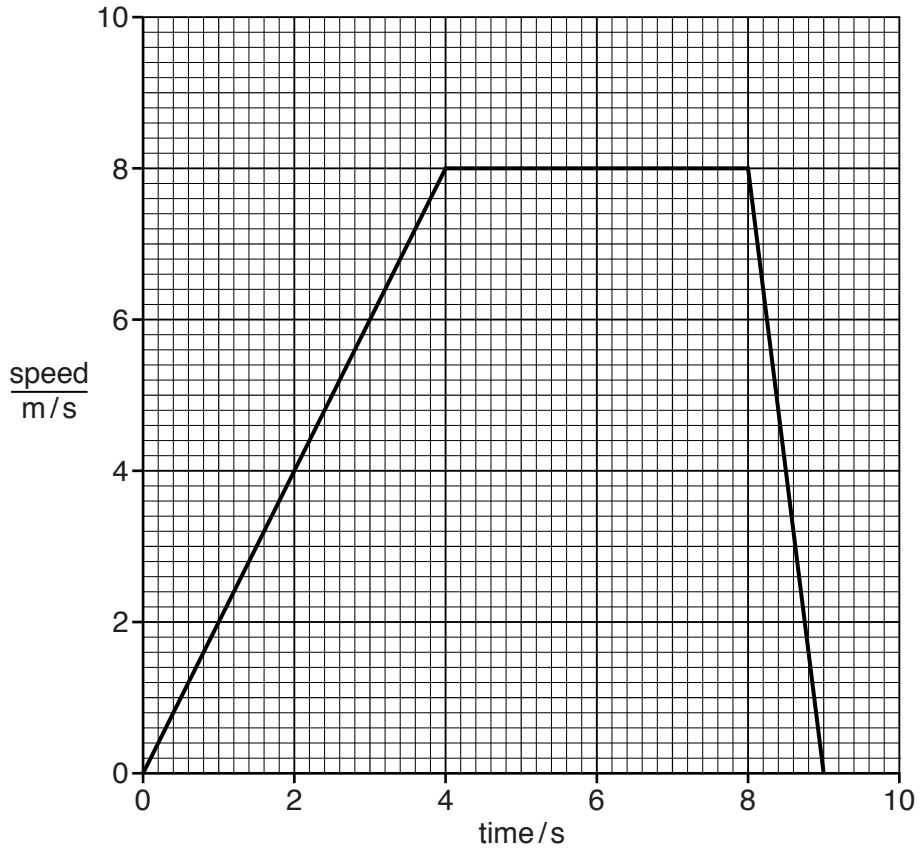

Fig. 3.3

- (i) On Fig. 3.3 write the letter **P** at the point when the brakes are first applied. [1]
- (ii) Use Fig. 3.3 to calculate the distance travelled by the cart

1. while it moves at constant speed.

State any formula you use and show your working.

formula

working

distance = m

2. from the time the brakes are applied until it comes to a stop.

Show your working.

distance = m

[3]

(c) Another cart with driver has a mass of 150 kg.

This cart travels down the slope through a vertical height of 10 m before entering the horizontal section of the track.

(i) Complete the energy transfers that take place while the cart is moving.

Frompotential energy..... at the top of the slope

tokinetic..... energy on the track

to energy as the cart stops.

[1]

(ii) Calculate the potential energy lost.
(gravitational field strength, $g = 10 \text{ N/kg}$).

State the formula you use and show your working.

formula

working

potential energy = J [2]

(iii) Calculate the maximum possible speed of the cart at the bottom of the slope.

State the formula you use and show your working.

formula

working

speed = m/s [3]

- 4 Fig. 4.1 shows a germinating seed and a diagram of one of the root hair cells as seen through the microscope.

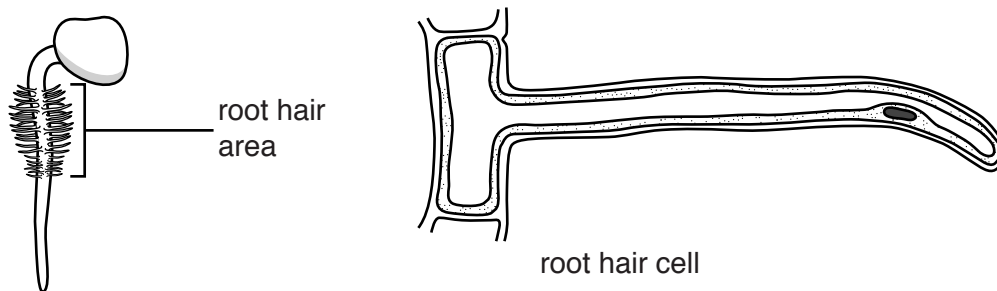

Fig. 4.1

- (a) Use the following terms to complete the sentences.

You may use each term once, more than once, or not at all.

amino acids **cell membrane** **cell wall** **ions**
nucleus **phloem** **xylem**

The root hair cell has a to control what enters and leaves the cell. It has a large surface area to absorb water and Water goes from the cell to the to be taken to the rest of the plant. [3]

- (b) A few days later the seedling in Fig. 4.1 develops leaves above ground and starts to photosynthesise.

- (i) Write the symbol equation for photosynthesis.

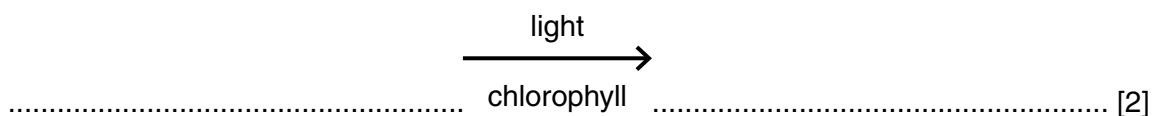

- (ii) Describe the role of chlorophyll in photosynthesis.

.....

 [2]

5 Fig. 5.1 shows the fractional distillation of petroleum.

Four of the fractions are labelled **P**, **Q**, **R** and **S**.

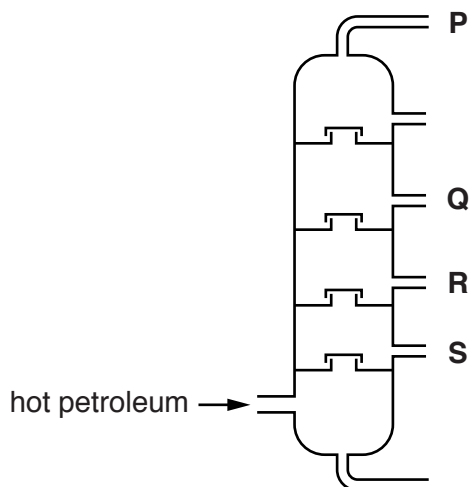

Fig. 5.1

(a) State which fraction from Fig. 5.1 has

the lowest boiling point range,

.....

the greatest molecular size.

.....

[2]

(b) Alkanes and alkenes are two types of hydrocarbon.

(i) Name the process used in the manufacture of alkenes from alkanes.

..... [1]

(ii) Fig. 5.2 shows three molecules.

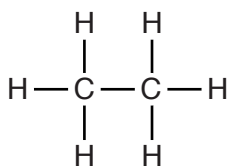

A

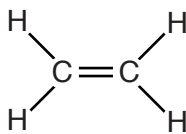

B

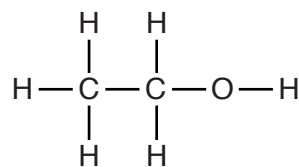

C

Fig. 5.2

State which molecule is an alkene and give a reason for your answer.

molecule

reason

.....

[1]

(iii) Alkanes and alkenes can be distinguished by a chemical test.

Name the chemical used in this test and state the observations for propane and for propene.

chemical name

propane observation

.....

propene observation

.....

[3]

6 Global warming causes ice caps to melt. This causes a rise in sea level.

(a) Warming of the water in the oceans causes the sea level to rise for a different reason.

Explain this reason.

.....
..... [1]

(b) Global warming happens when more of the infra-red radiation coming from the Sun is trapped in the Earth's surface and atmosphere.

(i) Table 6.1 shows part of the electromagnetic spectrum.

Table 6.1

gamma rays	X-rays					radio waves
------------	--------	--	--	--	--	-------------

In Table 6.1, place infra-red radiation in the correct position in the electromagnetic spectrum. [1]

(ii) A student said he thought infra-red radiation travels from the Sun more slowly than sunlight.

Explain why the student is **not** correct.

.....
..... [1]

(c) Global warming causes more water to evaporate from the sea, as the average speed of the molecules in the sea increases. This causes the temperature of the water in the sea surface to decrease slightly.

Suggest why evaporation causes a decrease in temperature in terms of the movement of water molecules.

.....
.....
.....
..... [2]

(d) When the Sun is shining on the Earth's surface, the temperature of the land increases more quickly than the temperature of the sea.

Suggest **one** reason why this happens.

.....
..... [1]

7 Fig. 7.1 shows the energy flow in an ecosystem on an island. The unit for each flow is kJ/m²/year.

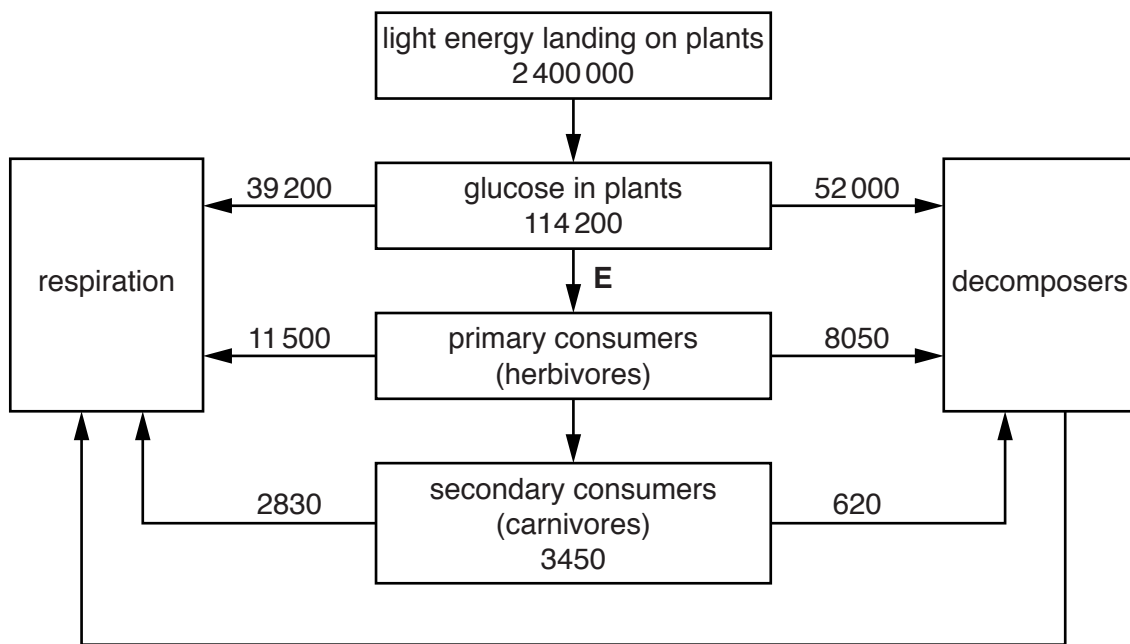

Fig. 7.1

(a) (i) Calculate the efficiency with which light energy landing on the plants is converted to glucose.

Show your working.

efficiency =% [2]

(ii) Calculate **E**, the amount of energy passed on to the primary consumers.

Show your working

E = kJ/m²/year [1]

(iii) Explain why there are not many trophic levels in this ecosystem.

.....

 [1]

(iv) Describe **one** way in which the plants use the energy released by respiration.

..... [1]

(b) Acid rain can affect ecosystems. The island is affected by acid rain that is carried by the wind from a factory on a different island.

(i) Describe how the factory could cause this acid rain.

.....
.....
.....
..... [2]

(ii) The acid rain reduces the growth of the plants on the island.

Suggest and explain how this affects the number of carnivores in the ecosystem in Fig. 7.1.

.....
.....
.....
..... [2]

8 Fig. 8.1 shows a piece of calcium reacting with dilute hydrochloric acid.

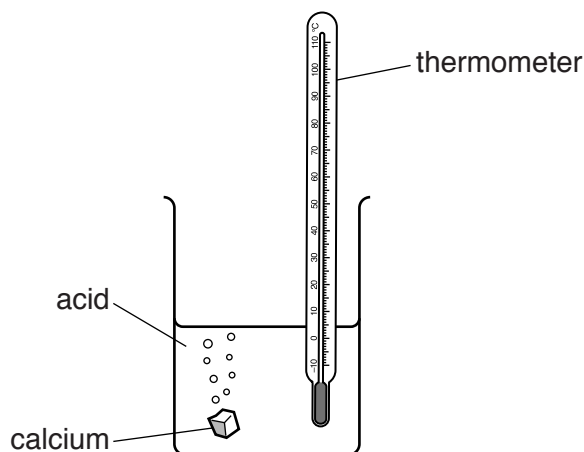

Fig. 8.1

(a) Complete the sentences about this reaction.

In this reaction the temperature increases. This shows that this is an
 reaction. The temperature rises because energy is converted into
 energy. [3]

(b) Describe and explain, in terms of colliding particles, any effect on the speed of the reaction caused by reducing the temperature of the acid.

effect
 explanation
 [2]

(c) (i) Describe and explain any effect on the speed of the reaction in Fig. 8.1 caused by replacing the piece of calcium by a piece of copper.

effect
 explanation
 [2]

(ii) Describe the method of extraction of copper from copper oxide.

.....
 [1]

- 9 A student wants to investigate the current through an electric buzzer. He designs the circuit in Fig. 9.1 to use in his investigation.

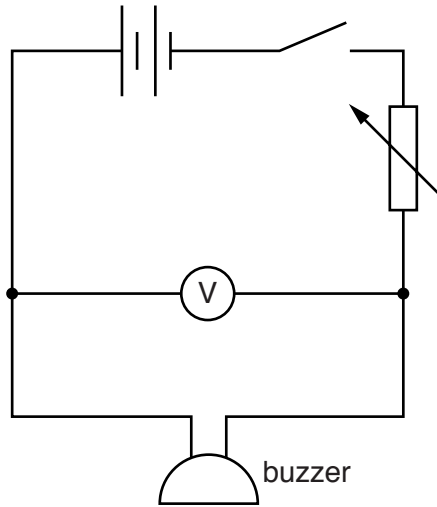
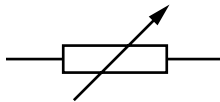

Fig. 9.1

- (a) (i) Name the component represented by this symbol.



..... [1]

- (ii) State and explain why the student includes this component in his circuit.

.....

 [2]

- (iii) The student has left out an important component from his circuit that is needed to measure the current.

On Fig. 9.2 complete the circuit diagram and include the symbol for this missing component in its correct place.

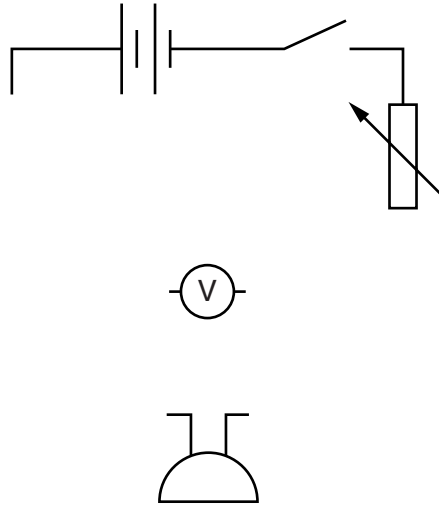

Fig. 9.2

[2]

- (b) The student uses the correct circuit for his experiment. Fig. 9.3 shows his results plotted as a graph.

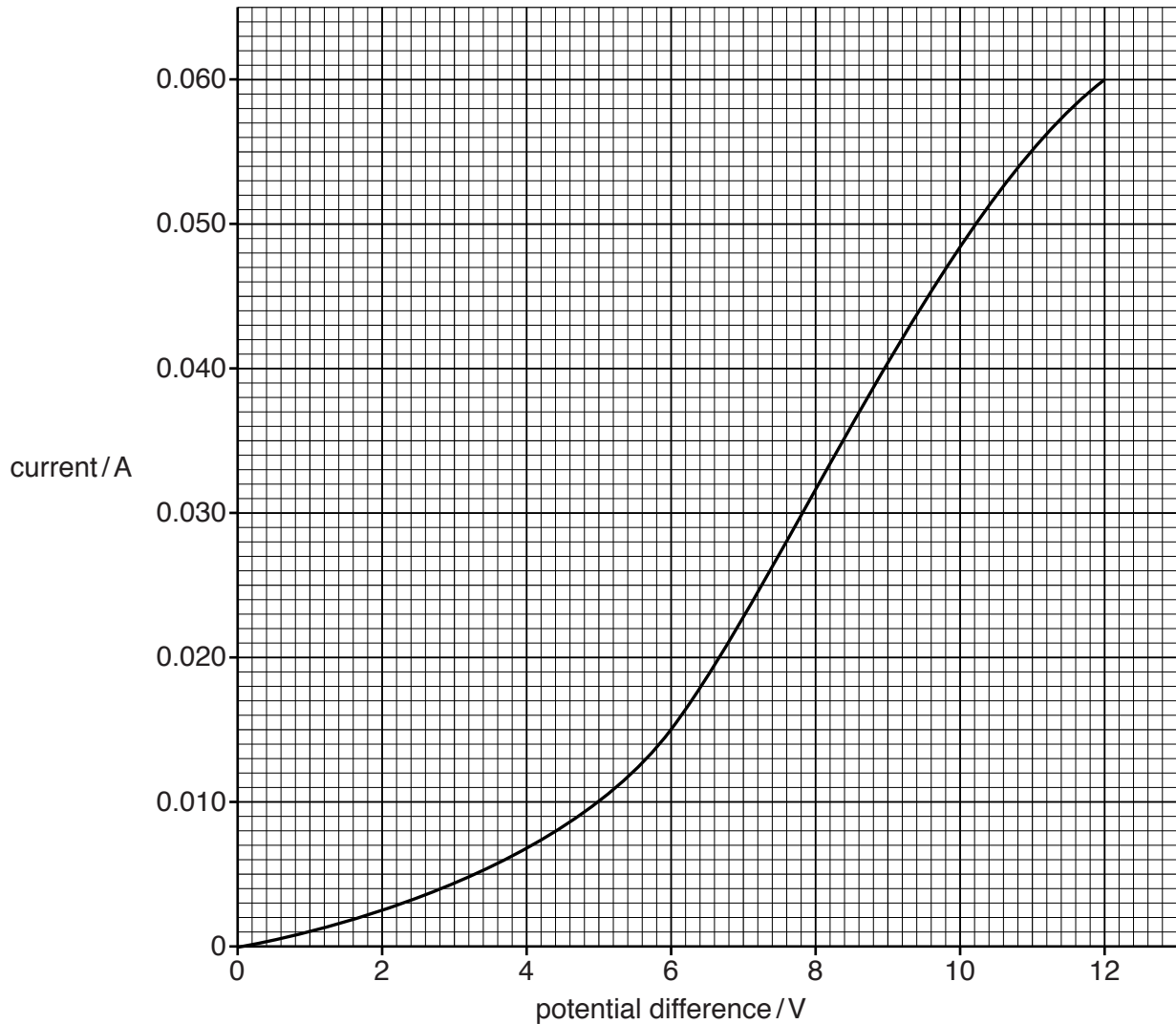

Fig. 9.3

The resistance of the buzzer is given by the formula

$$\text{resistance} = \frac{\text{potential difference (p.d.)}}{\text{current}}$$

The student says that the resistance of the buzzer is lower when the p.d. is 12V than when the p.d. is 6V. The resistance at 12V is 200 Ω .

Use information from the graph in Fig. 9.3 to calculate the resistance at 6V to show that he was correct.

resistance at 6V = Ω [2]

- (c) The buzzer emits a very loud sound at 3000Hz with a wavelength of 0.11m. A student 1km away from the buzzer hears the sound after a short time.

Calculate the time taken by the sound to reach the student.

State any formula you use and show your working.

formula

working

time =s [3]

