



UNIVERSITY OF CAMBRIDGE INTERNATIONAL EXAMINATIONS
International General Certificate of Secondary Education

CANDIDATE NAME

CENTRE NUMBER

--	--	--	--	--

CANDIDATE NUMBER

--	--	--	--

* 7 5 1 4 4 3 7 2 7 0 2 *

COMBINED SCIENCE

0653/21

Paper 2 (Core)

October/November 2011

1 hour 15 minutes

Candidates answer on the Question Paper.

No Additional Materials are required.

READ THESE INSTRUCTIONS FIRST

Write your Centre number, candidate number and name on all the work you hand in.

Write in dark blue or black pen.

You may use a soft pencil for any diagrams, graphs, tables or rough working.

Do not use staples, paper clips, highlighters, glue or correction fluid.

DO NOT WRITE IN ANY BARCODES.

Answer **all** questions.

A copy of the Periodic Table is printed on page 20.

At the end of the examination, fasten all your work securely together.

The number of marks is given in brackets [] at the end of each question or part question.

For Examiner's Use	
1	
2	
3	
4	
5	
6	
7	
8	
9	
Total	

This document consists of **20** printed pages.



- 1 The chemical reaction involved in the manufacture of ammonia requires an iron catalyst.

Fig.1.1 shows a simplified diagram of the reaction vessel in which ammonia is made.

For
Examiner's
Use

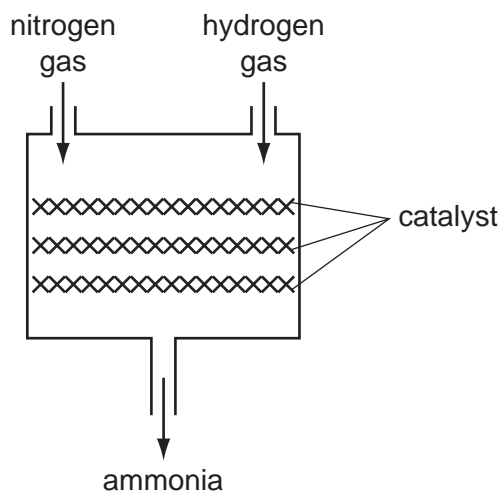

Fig. 1.1

- (a) (i) Explain the meaning of the term *catalyst*.

.....
..... [2]

- (ii) Iron is a member of the family of metals which lies between scandium and zinc in the Periodic Table.

Name this family of metals. [1]

- (iii) The iron catalyst is prepared by reacting iron oxide with hydrogen gas.

The balanced symbolic equation for this reaction is shown below.



State the total number of atoms shown on the **left hand side** of this equation.

..... [1]

- (iv) State the number of hydrogen molecules shown in the equation in (iii).

..... [1]

- (v) Explain why the reaction in (iii) is an example of a *redox reaction*.

.....
.....
..... [2]

- (b) (i) Complete the displayed (graphical) chemical formula of an ammonia molecule, NH_3 , which has been started below.

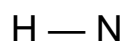

[2]

- (ii) A student states that an ammonia molecule contains **covalent** chemical bonds between its atoms.

Explain whether or not the student is correct.

.....
..... [1]

- 2 (a) The arrows in Fig. 2.1 show the horizontal forces acting on a car moving forwards. In each case the length of the arrow indicates the size of the force.

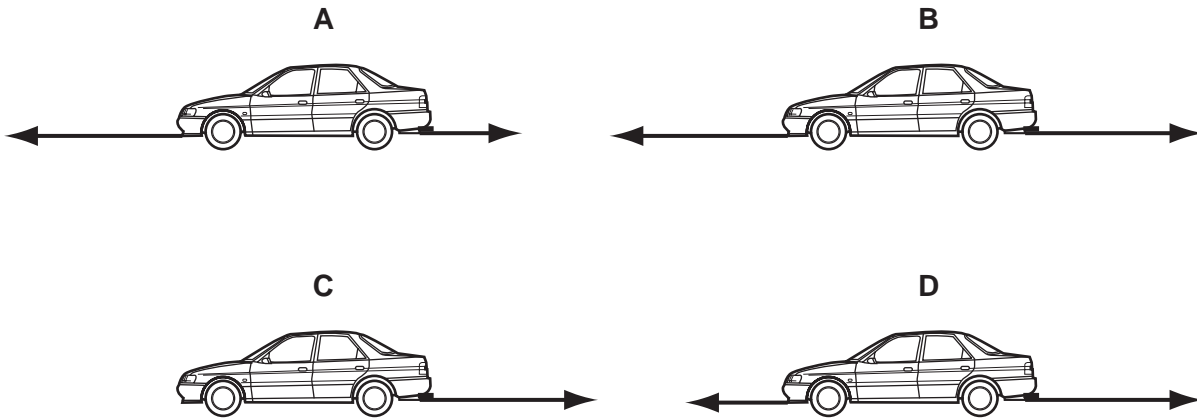

Fig. 2.1

- (i) State which of the diagrams out of **A**, **B**, **C** and **D** show a car that is slowing down.

..... [2]

- (ii) Explain how you decided on your answer to (i).

..... [1]

- (iii) There are other forces acting on the cars that are **not** horizontal.

Name **one** of these forces. [1]

- (b) The car has a radiator. This contains hot water that has been heated by passing it through the hot car engine.

The purpose of the radiator is to cool down the water. The radiator is painted black.

- (i) State the method by which heat is transferred from the hot water to the radiator.

..... [1]

- (ii) Explain why the radiator is painted black.

..... [1]

(c) Fig. 2.2 shows a racing car.

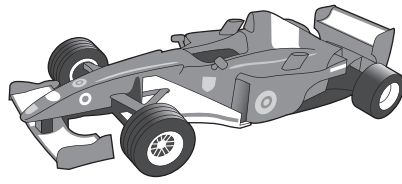

Fig. 2.2

The car took 1.5 hours to complete a race of 330 kilometres.

Calculate the average speed of the car in kilometres per hour.

State the formula that you use and show your working.

formula used

working

..... km/h [2]

(d) Fig. 2.3 shows the speed–time graph for the racing car over a short period of time.

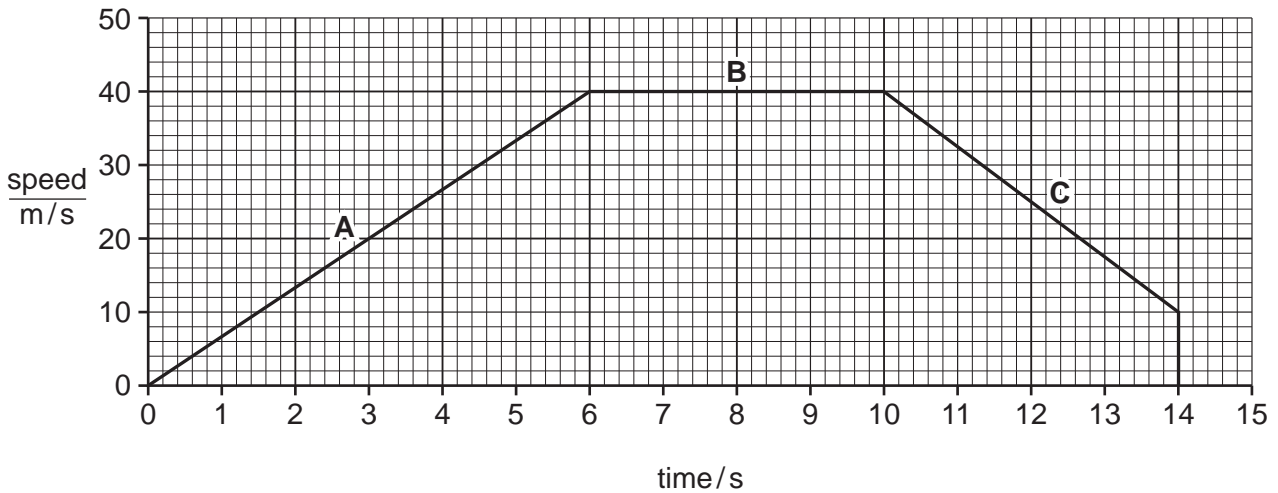

Fig. 2.3

Describe the motion of the racing car during

section **B**,

section **C**. [2]

For
Examiner's
Use

3 Rice and cassava are important parts of a person's diet in some parts of the world.

(a) Table 3.1 shows the main nutrients present in 100g of white rice and 100g of cassava.

Table 3.1

nutrient	white rice	cassava
protein/g	5.0	1.2
carbohydrate/g	58.6	34.7
fat/g	0.4	0.3

(i) Which of the nutrients listed in Table 3.1 can provide energy?

..... [1]

(ii) A diet that consists mostly of rice is better for a young child than a diet that consists mostly of cassava.

Use the information in Table 3.1 to explain **one** reason why this is so.

.....

 [2]

(iii) Carbohydrates include sugars and starch.

Describe how a student could test a sample of cooked rice to find out if it contains reducing sugar.

.....

 [3]

(b) Fig. 3.1 shows a cassava plant.

For
Examiner's
Use

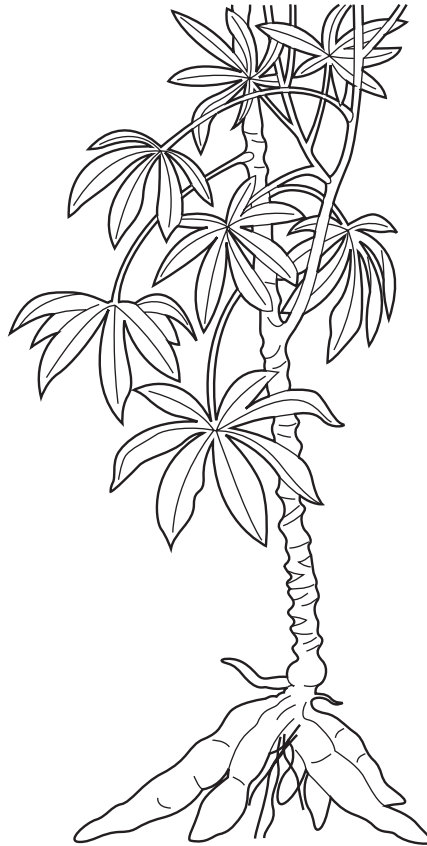

Fig. 3.1

The cassava plant makes food in its leaves.

(i) Describe how food is made by photosynthesis in a plant's leaves.

.....
.....
..... [2]

(ii) Suggest and explain **one** way, visible in Fig. 3.1, in which the structure of a cassava plant's leaves helps them to carry out photosynthesis.

.....
.....
..... [2]

4 (a) Fig. 4.1 shows an incomplete diagram of the electromagnetic spectrum.

radio waves		infra-red	visible light		X-rays	
--------------------	--	------------------	----------------------	--	---------------	--

Fig. 4.1

(i) Complete the diagram using terms from the list:

- gamma radiation microwaves ultraviolet**

[2]

(ii) State **one** use for

infra-red radiation,

.....

microwaves.

..... [2]

(b) Gamma radiation and X-rays are two examples of ionising radiation.

(i) Explain the meaning of the term *ionising radiation*.

.....

..... [2]

(ii) Explain why ionising radiation can be harmful to living things.

.....

.....

..... [2]

(c) Some types of food are treated with gamma radiation. The radiation kills the microbes that make food decay

(i) Explain why gamma radiation can be used for this, even when the fruit is packed in boxes.

.....
..... [1]

(ii) Fig. 4.2 shows how a conveyor belt can be used to move the boxes of fresh fruit past the radioactive source.

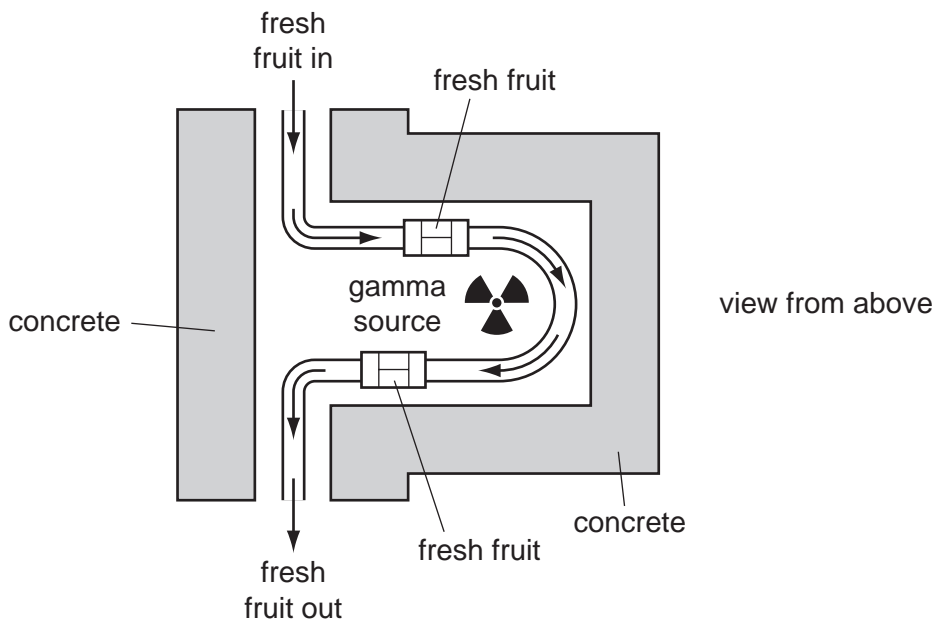

Fig. 4.2

Suggest why concrete is used to surround the radioactive source.

.....
..... [1]

- 5 Fig. 5.1 shows a piece of magnesium ribbon which a student has just dropped into a container of dilute sulfuric acid.

For
Examiner's
Use

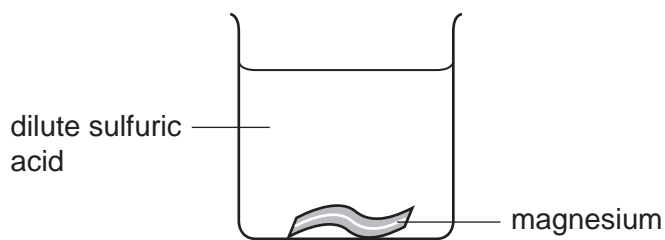

Fig. 5.1

- (a) (i) Describe **two** observations about this reaction which the student could make.

1

.....

2

..... [2]

- (ii) Complete the **word** chemical equation for the reaction in (i).

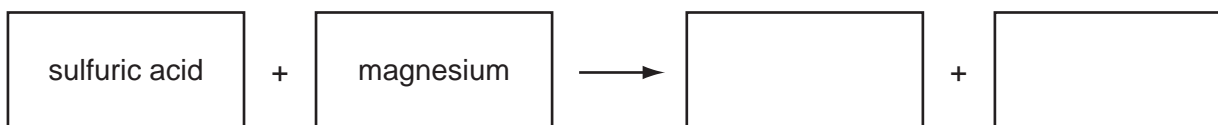

[2]

- (iii) State the **name** of the element which is present in both hydrochloric acid and sulfuric acid.

..... [1]

(b) Containers for dilute sulfuric acid are often made of poly(ethene). Poly(ethene) is a polymer which is formed from hydrocarbon monomers.

For
Examiner's
Use

(i) Suggest **one** property of poly(ethene) which makes it suitable for making sulfuric acid containers.

..... [1]

(ii) One method of dealing with waste poly(ethene) is to burn it.

Predict **two** compounds which will be produced when poly(ethene) is burnt.

1

2 [2]

(iii) Suggest **one** advantage of burning as a means of dealing with waste poly(ethene).

.....
..... [1]

6 Fig. 6.1 shows part of the human nervous system.

For
Examiner's
Use

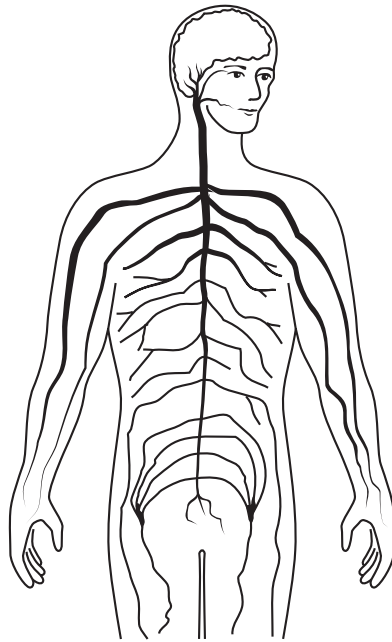

Fig. 6.1

(a) On Fig. 6.1, use label lines to indicate and name the **two** parts of the central nervous system. [2]

(b) If a person touches a hot pan with his finger, signals pass from his hand, through the central nervous system, to a muscle in his arm. The muscle contracts and moves the arm away.

State the correct biological term for each of the following descriptions.

(i) the cells in the finger that detect the hot pan and send signals to the central nervous system

..... [1]

(ii) an organ such as a muscle that responds to the signals

..... [1]

(c) A nerve cell has a nucleus and a cell surface membrane.

*For
Examiner's
Use*

(i) Name **one** type of cell in the human body that does **not** contain a nucleus.

..... [1]

(ii) The nucleus contains DNA. State the function of DNA.

.....
..... [1]

(iii) Outline **one** function of the cell surface membrane.

.....
..... [1]

7 Fig. 7.1 shows some data about the percentage by mass of elements in the Earth's crust.

For
Examiner's
Use

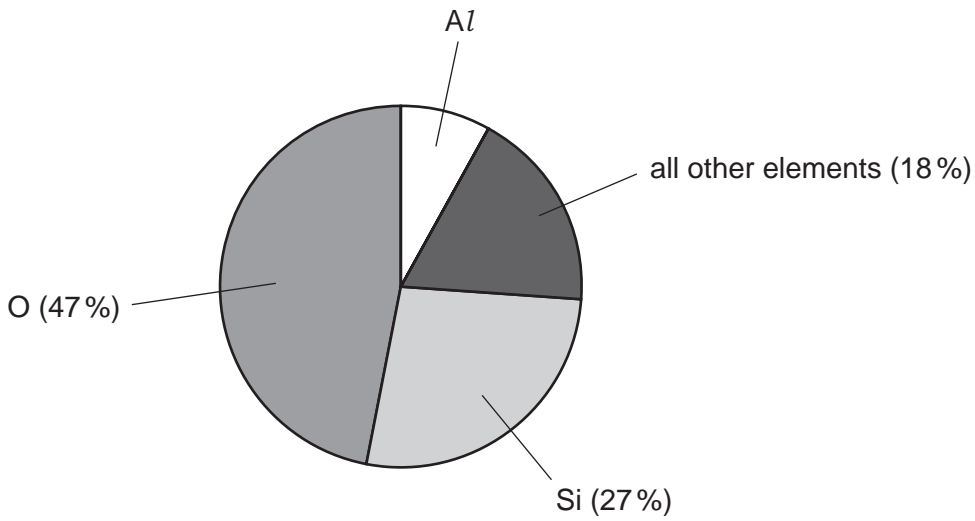

Fig. 7.1

(a) State the percentage by mass of aluminium in the Earth's crust.

..... [1]

(b) Fig. 7.2 shows a diagram of an ion of element E.

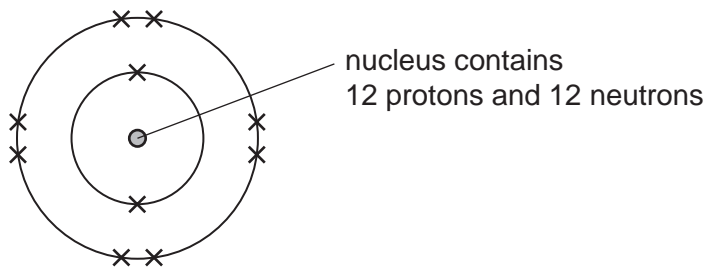

Fig. 7.2

(i) Name element E and explain how the diagram shows that the ion has a positive electrical charge.

name of element E

.....

 [3]

- (ii) Name the noble gas whose **atoms** have the same number of electrons as the ion shown in Fig. 7.2

..... [1]

- (iii) Explain, in terms of electron configuration, why the atoms of all the noble gases are unreactive.

.....
..... [1]

- (c) Fig. 7.3 shows a simplified diagram of a process which could be used to produce the reactive metal, sodium.

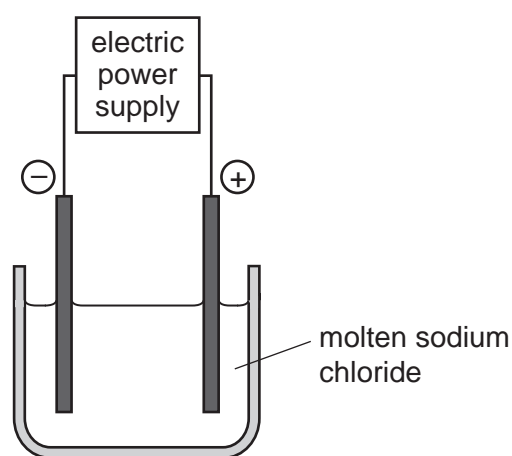

Fig. 7.3

- (i) Name the process shown in Fig. 7.3.

..... [1]

- (ii) Name the element which forms at the anode.

..... [1]

- 8 The golden lion tamarin is a species of monkey that lives in forests in Brazil. Its diet includes fruits and nectar from trees. Its predators include snakes, bamboo rats and owls.

For
Examiner's
Use



- (a) (i) In the space below, complete the food web, using the information above.

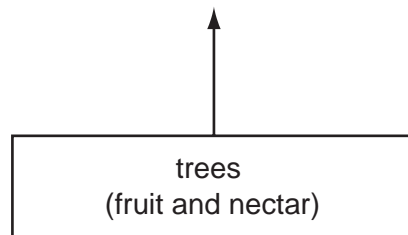

[3]

- (ii) On your food web, draw a circle around the producer.

[1]

- (b) The nectar that the monkeys eat is made by flowers that grow on some of the trees in the forests. The fruits that the monkeys eat develop from the flowers.

For
Examiner's
Use

Fig. 8.1 shows a section through a flower.

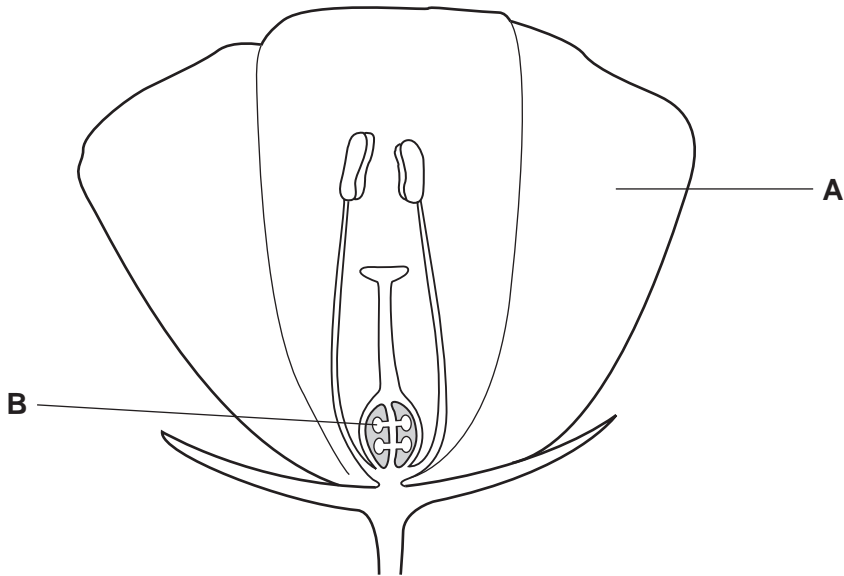

Fig. 8.1

- (i) Name the parts labelled **A** and **B**.

A

B

[2]

- (ii) On Fig. 8.1, label the part that produces pollen, using a label line and the letter **P**. [1]

- (iii) On Fig. 8.1, label the part that will develop into a fruit, using a label line and the letter **F**. [1]

- (iv) Explain why the flower produces nectar.

.....
.....
..... [2]

- 9 (a) Fig. 9.1 shows the circuit diagram of a circuit which a student set up. He measured the current passing through the $2\ \Omega$ resistor. The ammeter reading was 6 A.

For
Examiner's
Use

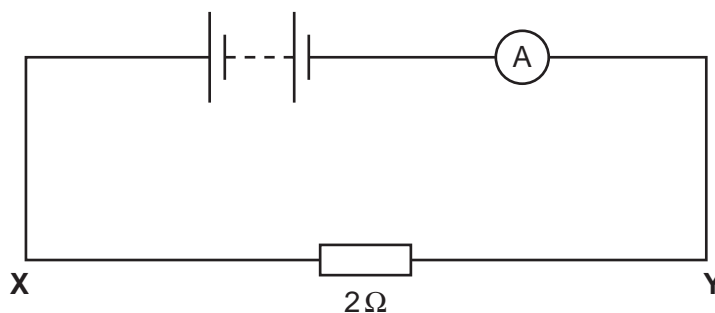

Fig. 9.1

- (i) Show that the voltage across the resistor was 12 V.

State the formula that you use and show your working.

formula used

working

[2]

- (ii) A $4\ \Omega$ resistor is placed in series with the $2\ \Omega$ resistor between X and Y.

Calculate the total resistance between X and Y.

State the formula that you use and show your working.

formula used

working

..... Ω [2]

(b) Many countries are seeking alternatives to fossil fuels as energy sources for generating electricity.

*For
Examiner's
Use*

Explain why is it necessary to find alternative energy sources for generating electricity.

.....
.....
.....
..... [2]

