



UNIVERSITY OF CAMBRIDGE INTERNATIONAL EXAMINATIONS
International General Certificate of Secondary Education

COMBINED SCIENCE

0653/01

Paper 1 Multiple Choice

May/June 2008

45 minutes

Additional Materials: Multiple Choice Answer Sheet
 Soft clean eraser
 Soft pencil (type B or HB is recommended)

* 7 8 0 3 5 4 9 5 2 1 *

READ THESE INSTRUCTIONS FIRST

Write in soft pencil.

Do not use staples, paper clips, highlighters, glue or correction fluid.

Write your name, Centre number and candidate number on the Answer Sheet in the spaces provided unless this has been done for you.

There are **forty** questions on this paper. Answer **all** questions. For each question there are four possible answers **A, B, C** and **D**.

Choose the **one** you consider correct and record your choice in **soft pencil** on the separate Answer Sheet.

Read the instructions on the Answer Sheet very carefully.

Each correct answer will score one mark. A mark will not be deducted for a wrong answer.

Any rough working should be done in this booklet.

A copy of the Periodic Table is printed on page 20.

This document consists of **18** printed pages and **2** blank pages.



1 Which part of a plant cell is formed from cellulose?

- A cell surface membrane
- B cell wall
- C chloroplasts
- D cytoplasm

2 An experiment is set up as shown.

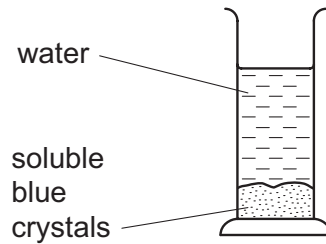

After several hours, the water turns blue.

Which process causes this colour change to take place?

- A absorption
- B diffusion
- C digestion
- D evaporation

3 The enzyme catalase is found in liver cells. A cube of boiled liver and a cube of raw liver are added to solutions of hydrogen peroxide.

Which shows the result of this experiment?

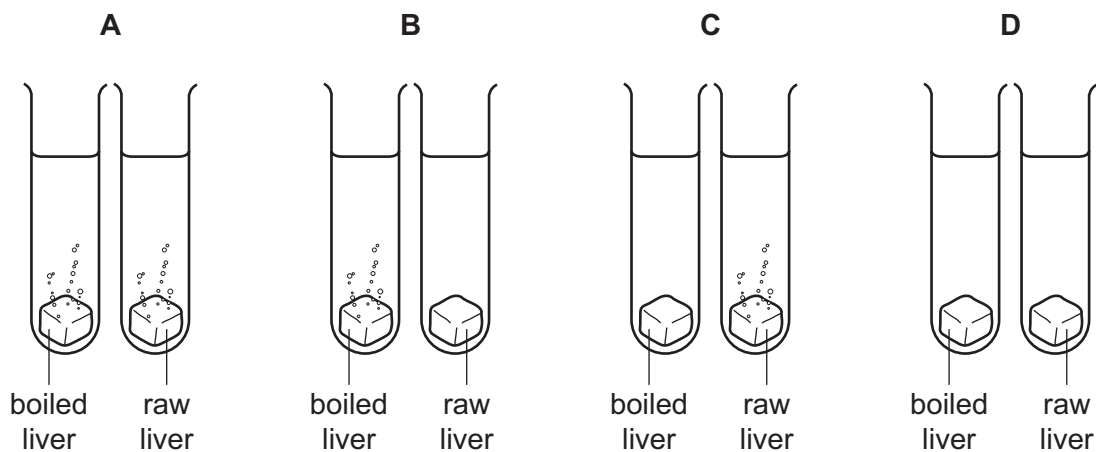

4 Which two chemical substances are required for photosynthesis?

- A carbon dioxide and glucose
- B glucose and oxygen
- C oxygen and water
- D water and carbon dioxide

5 The diagram shows two identical plants in different conditions.

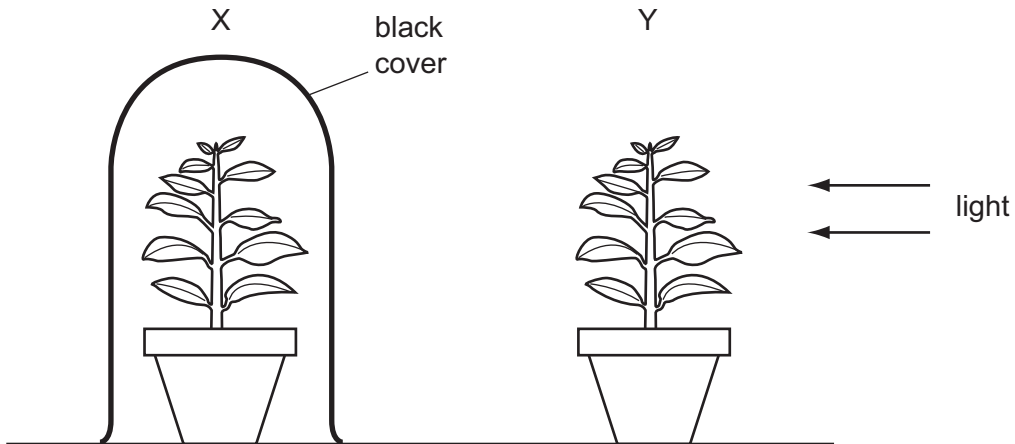

Which processes occur in plant X and in plant Y?

	X		Y	
	photosynthesis	respiration	photosynthesis	respiration
A	✓	x	✓	x
B	x	✓	✓	✓
C	x	✓	✓	x
D	x	x	✓	✓

key

✓ = process occurs

x = process does not occur

6 The blockage of which blood vessel causes a heart attack?

- A aorta
- B coronary artery
- C pulmonary artery
- D pulmonary vein

7 The flow chart shows a green leaf being tested for the presence of starch.

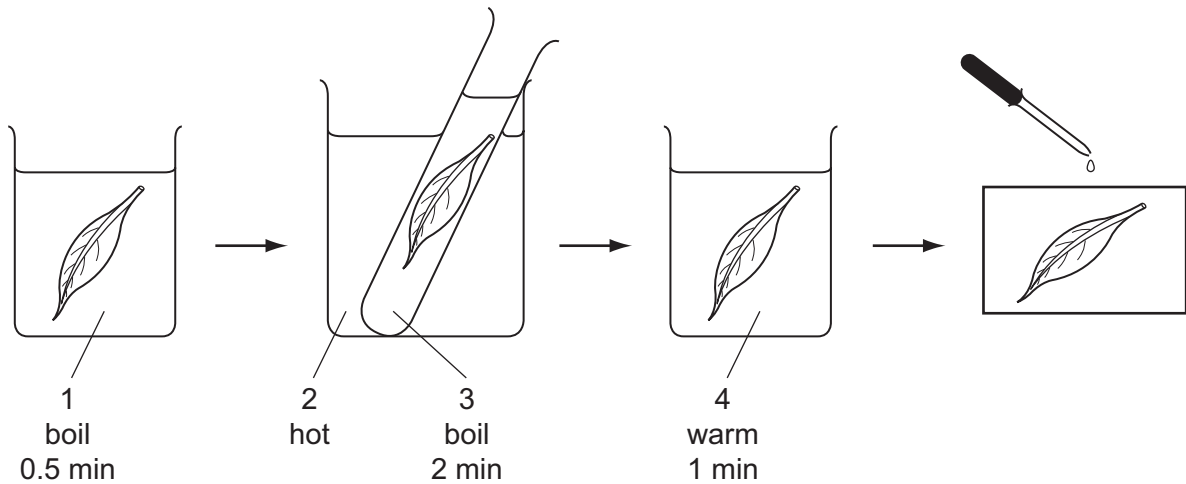

What are substances 1, 2, 3 and 4?

	1	2	3	4
A	alcohol	water	iodine	water
B	water	alcohol	water	iodine
C	water	water	alcohol	iodine
D	water	water	alcohol	water

8 How does drinking alcohol affect the nervous system?

	time taken for impulse to pass from receptor to CNS	time taken for impulse to pass from CNS to effector
A	decreases	decreases
B	decreases	increases
C	increases	decreases
D	increases	increases

9 The diagram shows a section through the female reproductive system.

Where is the fertilised ovum implanted?

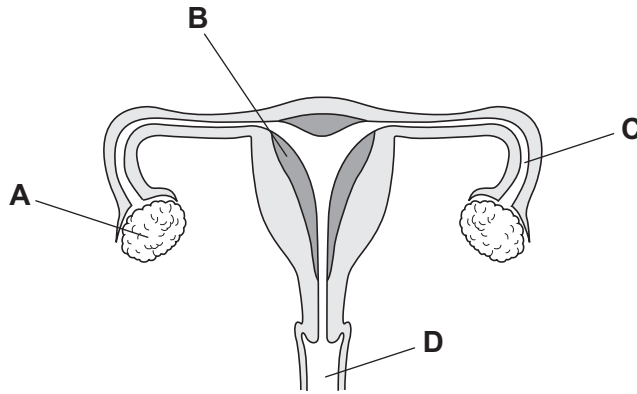

10 A potato is cut into two portions, X and Y. Both portions produce shoots that grow into new plants.

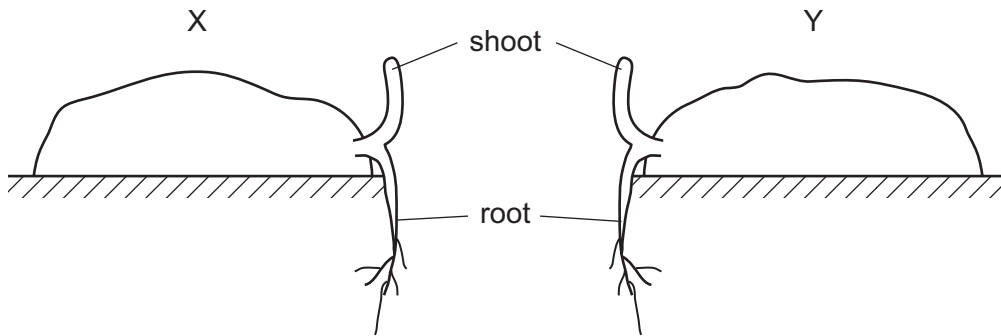

Which statement about the two new plants is **not** true?

- A They are clones.
- B They come from different zygotes.
- C They contain identical genes in each cell.
- D They have the same parent.

11 Which type of variation can be inherited by offspring?

	variation caused by genes	variation caused by environment
A	✓	✓
B	✓	x
C	x	✓
D	x	x

key

✓ = variation can be inherited

x = variation cannot be inherited

12 The diagram shows a food web for a lake.

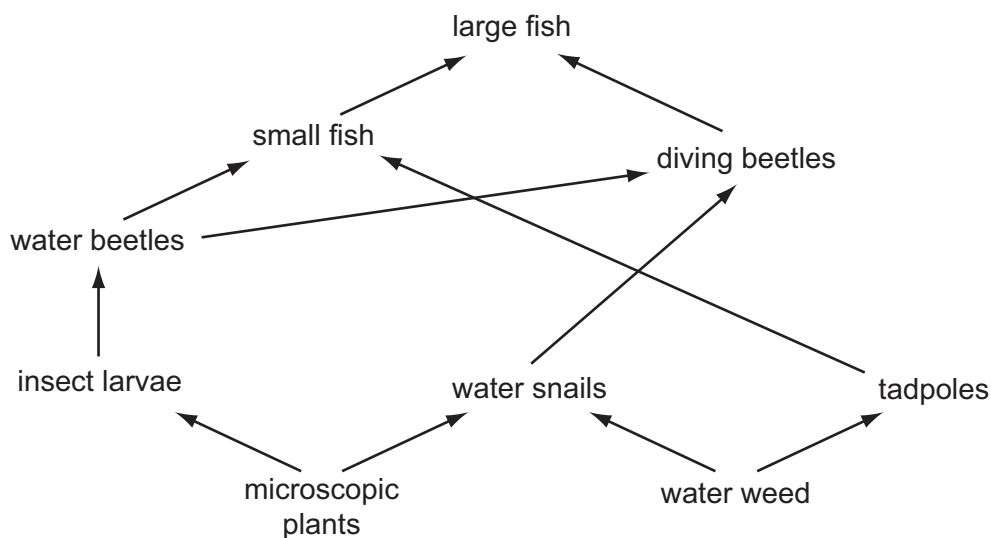

Which is a food chain from this web?

- A microscopic plants → tadpoles → small fish → large fish
 - B microscopic plants → insect larvae → water beetles → tadpoles
 - C microscopic plants → water snails → diving beetles → large fish
 - D microscopic plants → water snails → water weed → tadpoles
- 13 Which procedure would reduce soil erosion?
- A allowing large numbers of sheep to graze on grassland
 - B changing sloping farmland into terraced fields
 - C cutting down rainforests for agricultural use
 - D reducing the number of trees on hillsides
- 14 Which method of separation can be used to obtain pure water from aqueous potassium chloride?
- A chromatography
 - B crystallisation
 - C distillation
 - D filtration

15 Which diagrams correctly show the displayed formula of ammonia and of carbon dioxide?

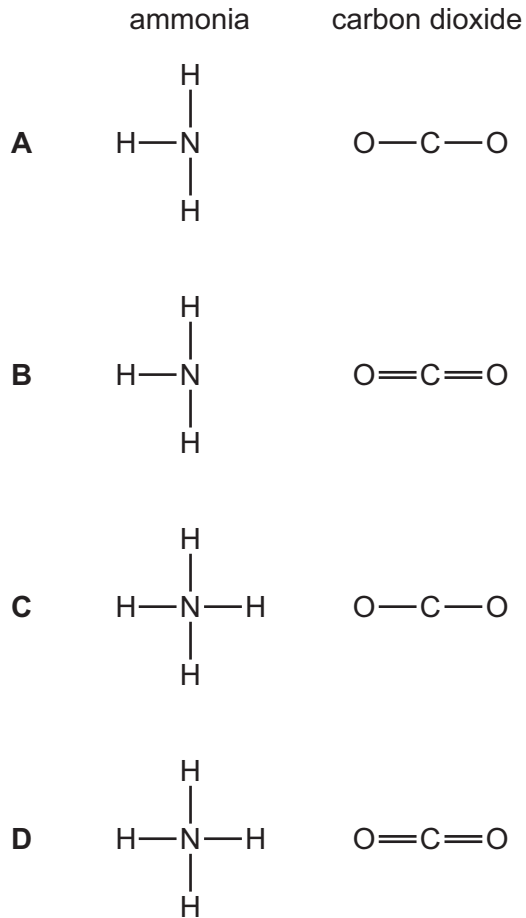

16 The numbers of neutrons and protons present in the nuclei of four atoms are shown.

atom	number of neutrons	number of protons
1	11	12
2	12	11
3	13	13
4	13	11

Which two atoms are of the same element?

- A** 1 and 2 **B** 2 and 3 **C** 2 and 4 **D** 3 and 4

17 How many atoms are present in each of the molecules of the following components in air?

	nitrogen	noble gases	oxygen	water vapour
A	1	1	1	2
B	2	1	2	3
C	2	2	2	2
D	2	2	2	3

18 A solid **X** is placed in the circuit shown. The lamp lights.

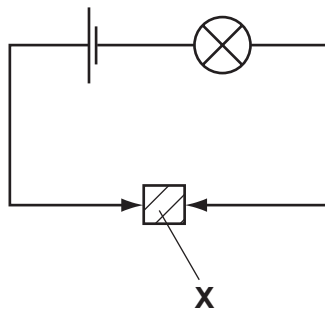

What could solid **X** be?

	steel	graphite
A	✓	✓
B	✓	x
C	x	✓
D	x	x

19 Which metal reacts dangerously when added to dilute sulphuric acid?

- A** copper
- B** magnesium
- C** sodium
- D** zinc

20 The diagram shows a razor used in shaving.

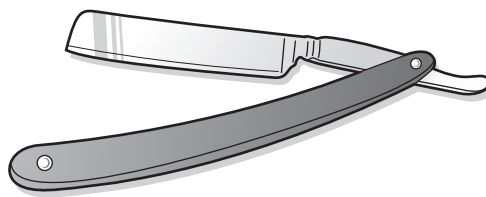

Why is the razor made of stainless steel and **not** pure iron?

- A It is a compound but iron is an element.
- B It is easier to polish than is iron.
- C It is more brittle than iron.
- D It is more resistant to rusting than is iron.

21 The diagram shows an experiment on the composition of air.

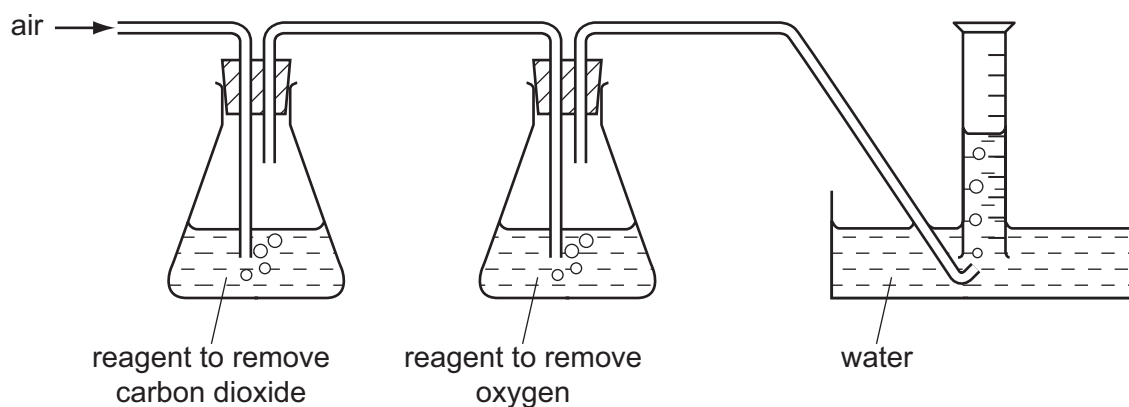

The volume of the air that passes into the apparatus is 100 cm^3 .

What is the volume and the composition of the gas collected in the measuring cylinder?

	volume / cm^3	composition
A	20	pure nitrogen
B	20	nitrogen and other gases
C	80	pure nitrogen
D	80	nitrogen and other gases

22 Which aqueous reagents give a white precipitate when added to aqueous zinc chloride?

	sodium hydroxide	barium nitrate	silver nitrate
A	✓	✓	✓
B	✓	✓	x
C	✓	x	✓
D	x	✓	✓

23 Some calcium carbonate and hydrochloric acid start to react. Water is then added to the reaction mixture.

What happens to the speed of the reaction?

- A** It decreases.
- B** It increases.
- C** It stays the same.
- D** It stops.

24 The apparatus shown is set up.

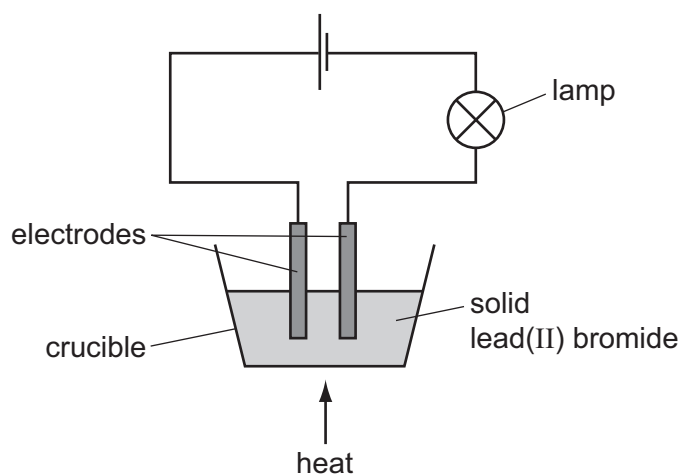

The crucible needs to be heated for the bulb to give out light.

Why is heat needed?

- A** An exothermic reaction takes place in the crucible.
- B** Electrodes only conduct electricity when hot.
- C** Heat causes the lead(II) bromide to react with air.
- D** The lead(II) bromide has to be melted.

25 Crude oil (petroleum) is a source of hydrocarbon fuels.

Other fuels are coal and wood.

Are coal, wood and crude oil described as 'fossil fuels'?

	coal	wood	crude oil
A	yes	yes	no
B	yes	no	yes
C	no	yes	yes
D	yes	yes	yes

26 Why is water often used to extinguish fires?

- A** The boiling point of water is 100°C
- B** Water is a compound containing oxygen and hydrogen.
- C** Water removes heat from the fire.
- D** Water reacts with most fuels.

27 The sentence about making long chain molecules is incomplete.

When a1..... number of molecules called2..... combine, the larger molecule formed is a3..... .

Which words correctly complete gaps 1, 2 and 3?

	1	2	3
A	large	monomers	polymer
B	large	polymers	monomer
C	small	monomers	polymer
D	small	polymers	monomer

28 Some liquid is heated in a flask.

The diagrams show the height of the liquid in the tube when the liquid is cold and when it is hot.

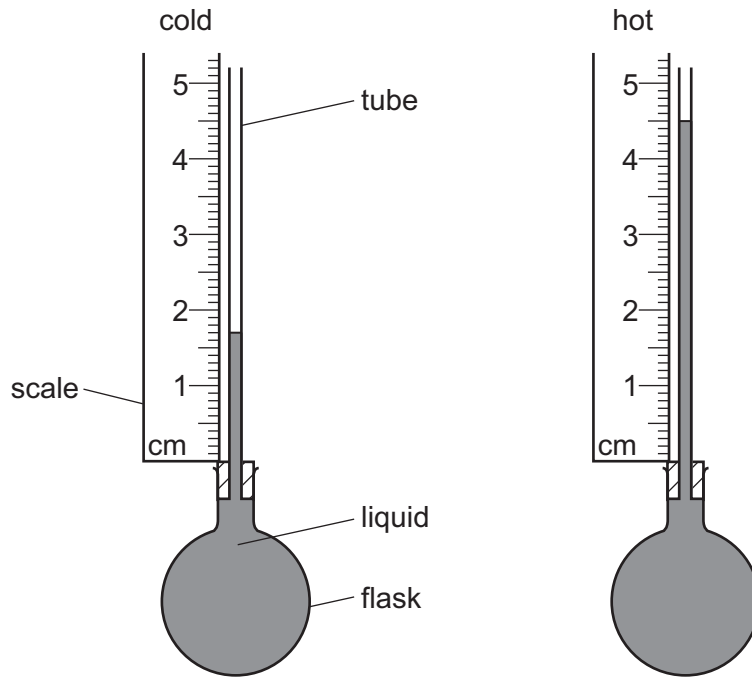

What is the difference in the heights?

- A** 1.7 cm **B** 2.8 cm **C** 3.2 cm **D** 4.5 cm

29 The speed-time graph shown is for a bus travelling between stops.

Where on the graph is the acceleration of the bus the greatest?

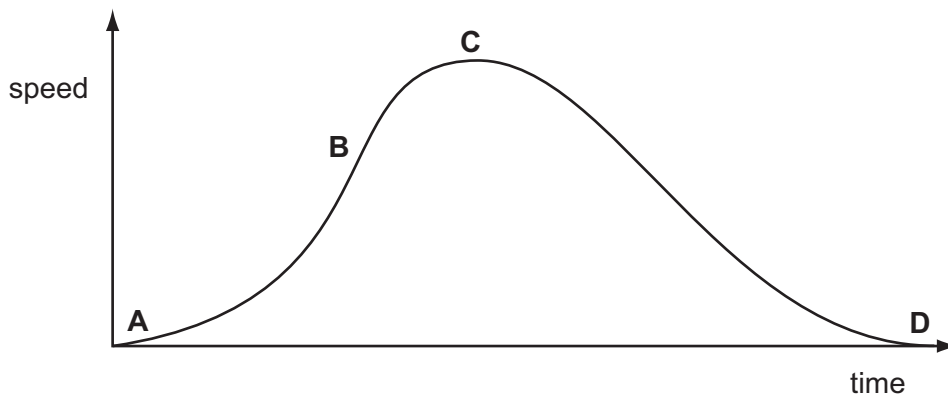

- 30 The circuit of a motor racing track is 3 km in length. In a race, a car goes 25 times round the circuit in 30 minutes.

What is the average speed of the car?

- A 75 km/hour
 B 90 km/hour
 C 150 km/hour
 D 750 km/hour

- 31 The diagram shows a rectangular metal block measuring 10 cm × 5.0 cm × 2.0 cm.

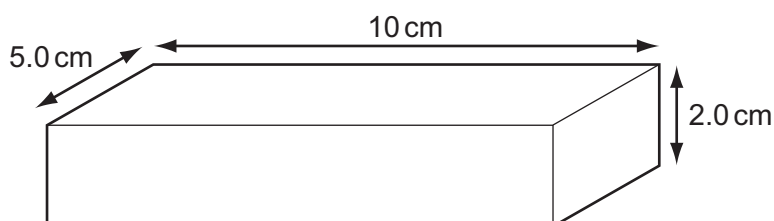

Its mass is 250 g.

What is the density of the metal?

- A 0.20 g/cm³ B 0.40 g/cm³ C 2.5 g/cm³ D 5.0 g/cm³

- 32 The diagram shows an experiment to find the density of a liquid.

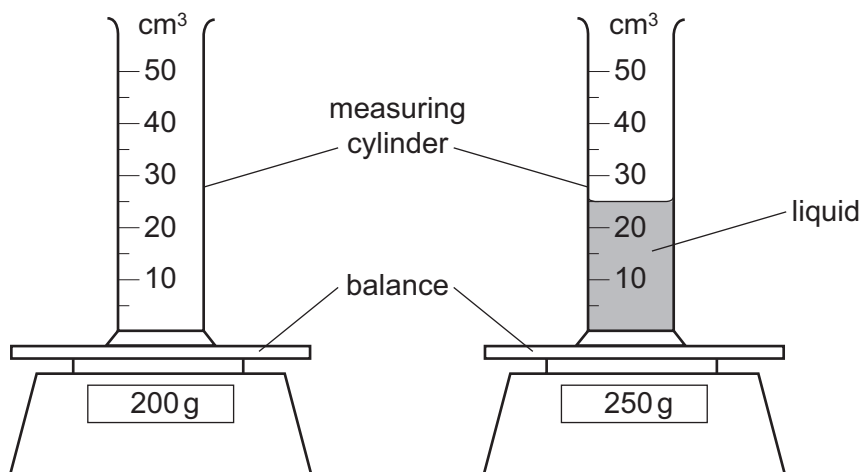

What is the density of the liquid?

- A 0.5 g/cm³ B 2.0 g/cm³ C 8.0 g/cm³ D 10.0 g/cm³

33 A stone is thrown from the edge of a cliff. Its path is shown in the diagram.

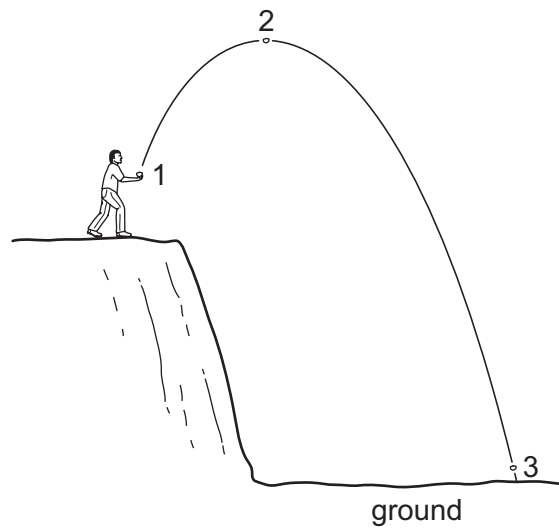

In which position does the stone have its greatest kinetic energy and in which position does it have its lowest potential energy?

	greatest kinetic energy	lowest potential energy
A	1	2
B	2	3
C	3	1
D	3	3

34 A heater is placed in a room.

Which diagram shows the movement of air as the room is heated?

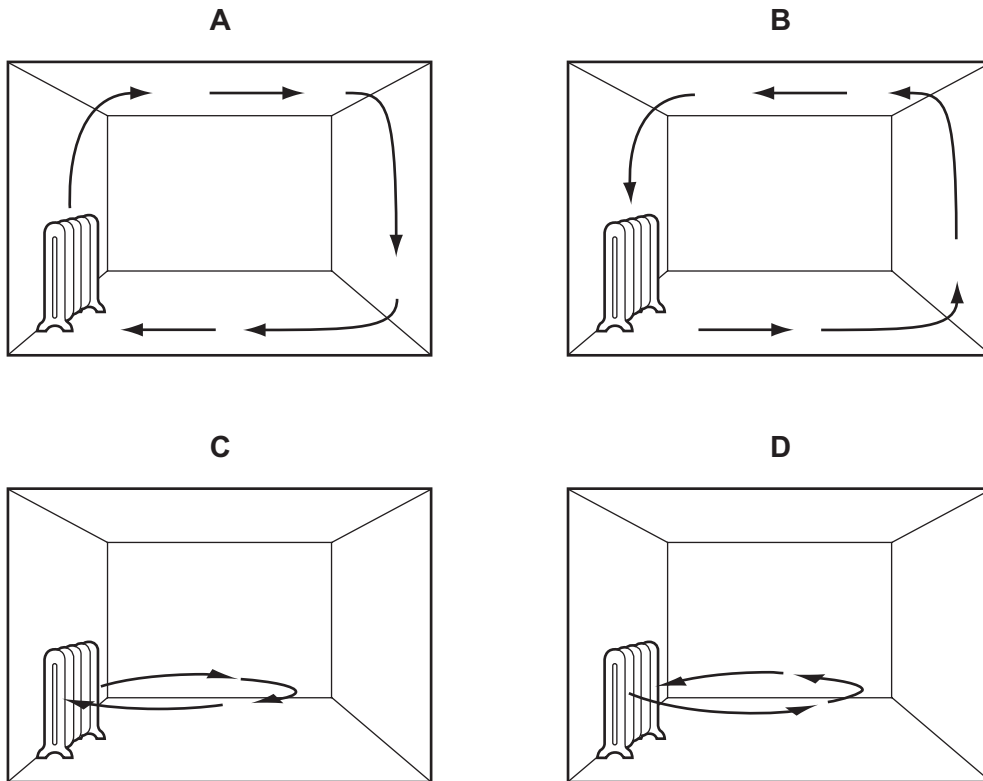

35 Rays from the Sun pass through a narrow slit and a spectrum is produced on a screen.

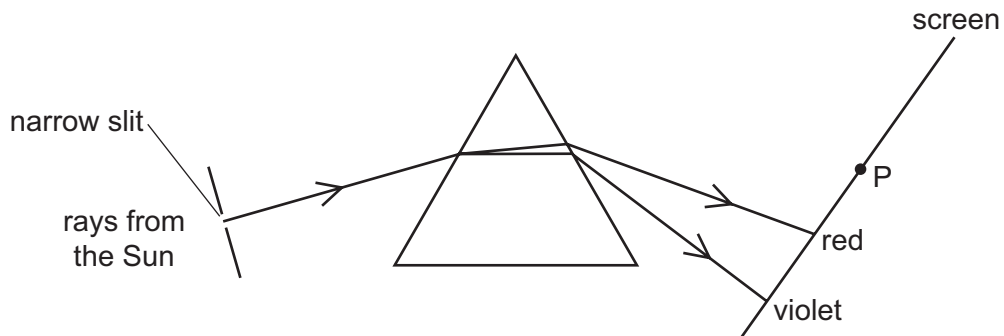

A thermometer placed at P shows a large temperature rise.

Which type of radiation causes this?

- A infra-red
- B microwave
- C ultra-violet
- D visible light

- 36 Two thin converging lenses, X and Y, are used as shown to give a focused image of an illuminated slit. The rays shown are parallel between X and Y.

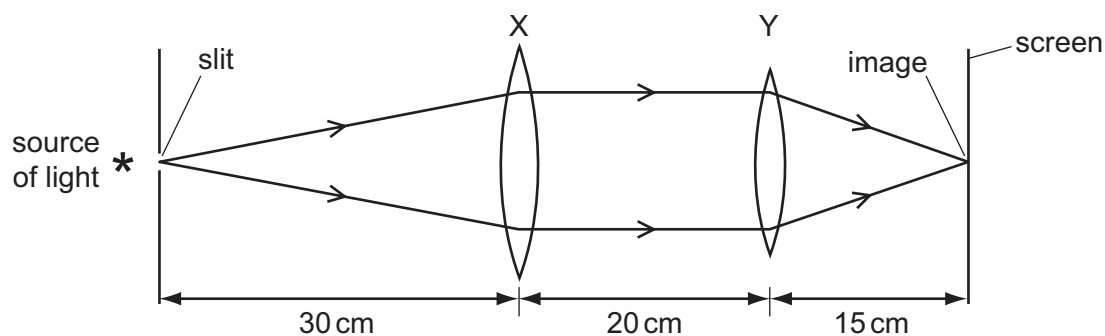

What are the correct values for the focal lengths of X and of Y?

	focal length of X/cm	focal length of Y/cm
A	50	35
B	30	20
C	30	15
D	20	20

- 37 In the circuit shown, the switches S_1 and S_2 may be open (off) or closed (on).

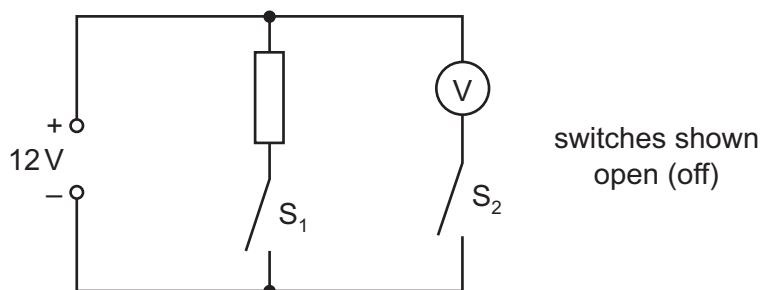

Which line in the table shows the voltmeter reading for the switch positions given?

	S_1	S_2	voltmeter reading /V
A	open	open	12
B	closed	closed	12
C	open	closed	0
D	closed	open	12

- 38 The device X in this circuit is designed to cut off the electricity supply if too much current flows.

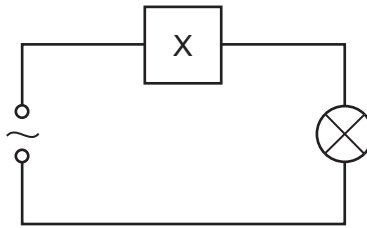

What is device X?

- A a fuse
 - B a relay
 - C a resistor
 - D an ammeter
- 39 The diagram shows a transformer connected to a 240V a.c. supply.

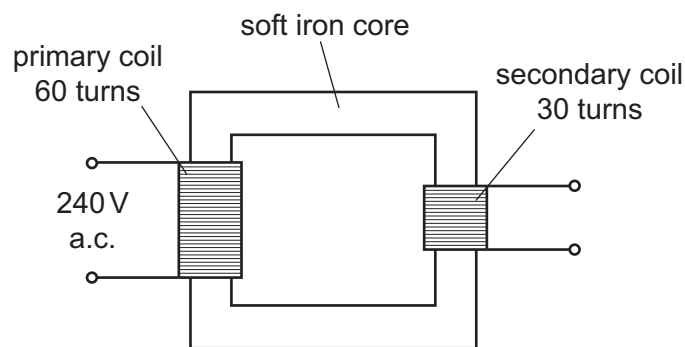

What is the potential difference across the secondary coil of the transformer?

- A 30V
 - B 120V
 - C 240V
 - D 480V
- 40 There are three types of emission from radioactive substances.

Which types carry an electric charge?

- A alpha-particles and beta-particles only
- B alpha-particles and gamma-rays only
- C beta-particles and gamma-rays only
- D all three types

BLANK PAGE

BLANK PAGE

