



UNIVERSITY OF CAMBRIDGE INTERNATIONAL EXAMINATIONS
International General Certificate of Secondary Education

COMBINED SCIENCE

0653/01

Paper 1 Multiple Choice

May/June 2007

45 minutes

Additional Materials: Multiple Choice Answer Sheet
 Soft clean eraser
 Soft pencil (type B or HB is recommended)

* 8 0 4 1 9 9 5 9 3 3 *

READ THESE INSTRUCTIONS FIRST

Write in soft pencil.

Do not use staples, paper clips, highlighters, glue or correction fluid.

Write your name, Centre number and candidate number on the Answer Sheet in the spaces provided unless this has been done for you.

There are **forty** questions on this paper. Answer **all** questions. For each question there are four possible answers **A, B, C** and **D**.

Choose the **one** you consider correct and record your choice in **soft pencil** on the separate Answer Sheet.

Read the instructions on the Answer Sheet very carefully.

Each correct answer will score one mark. A mark will not be deducted for a wrong answer.

Any rough working should be done in this booklet.

A copy of the Periodic Table is printed on page 20.

This document consists of **19** printed pages and **1** blank page.



- 1 The table describes some parts of a plant cell.

Which part is the cellulose cell wall?

part	feature
A	allows free passage of water and dissolved substances
B	contains DNA
C	is partially permeable
D	synthesises glucose in sunlight

- 2 The diagrams show experiments to investigate the activity of the enzyme catalase which is found in potato.

In which test-tube is oxygen produced fastest?

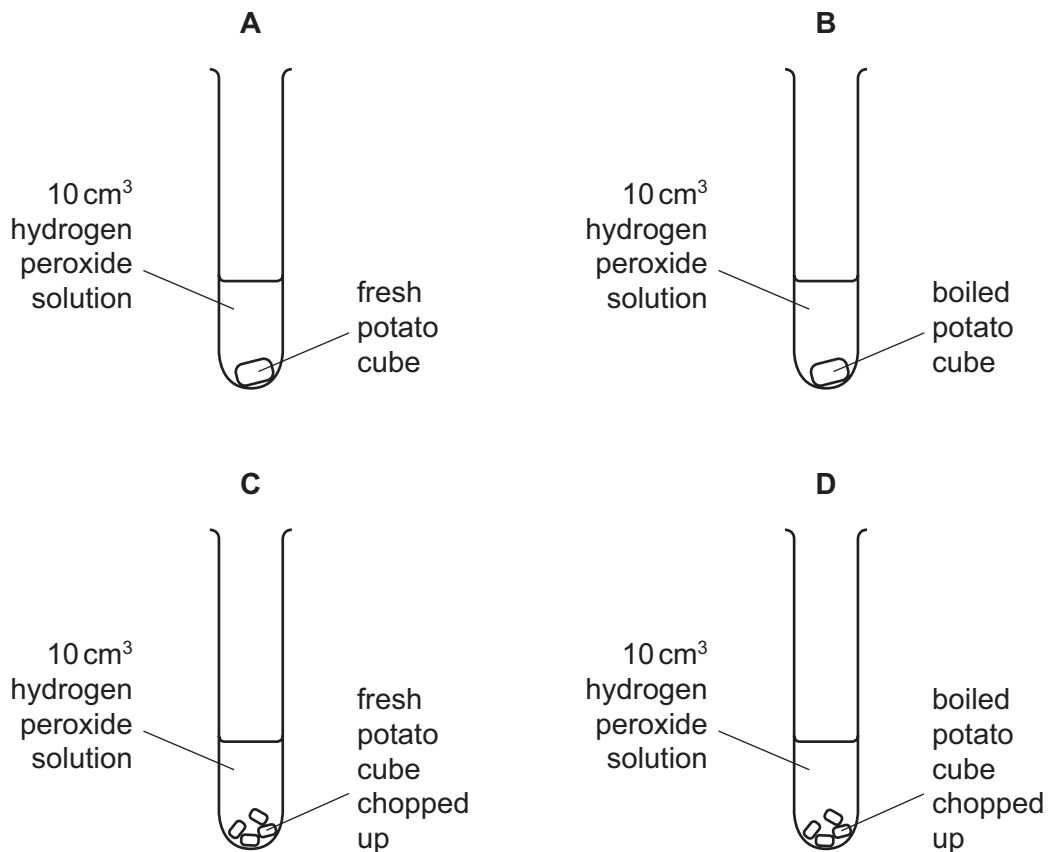

3 The flow diagram shows the stages in testing a green leaf for starch.

1, 2, 3 and 4 are all liquids.

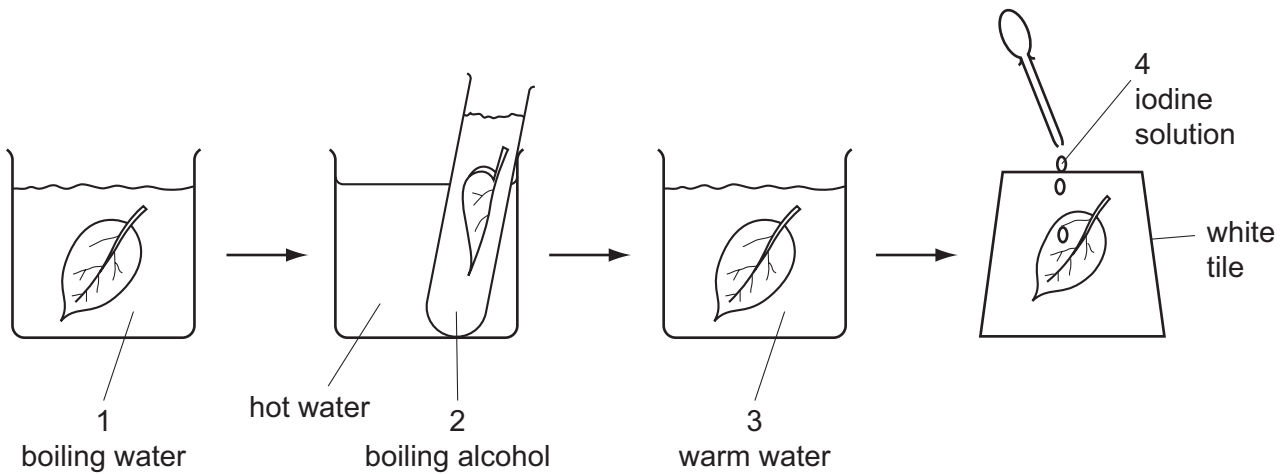

What are the colours of liquids 1, 2, 3 and 4 at the end of each stage for a leaf that contains starch?

	1	2	3	4
A	colourless	green	colourless	blue/black
B	colourless	colourless	green	brown
C	green	colourless	colourless	blue/black
D	green	green	colourless	brown

4 The diagram shows a vertical section through an incisor in the jaw.

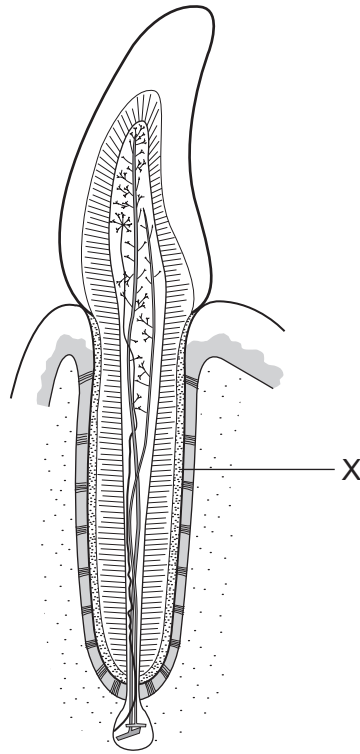

What is the name of the part labelled X?

- A cement
- B dentine
- C enamel
- D pulp

- 5 Four students assembled apparatus intended to show that air breathed out contains more carbon dioxide than air breathed in.

Which apparatus is assembled correctly?

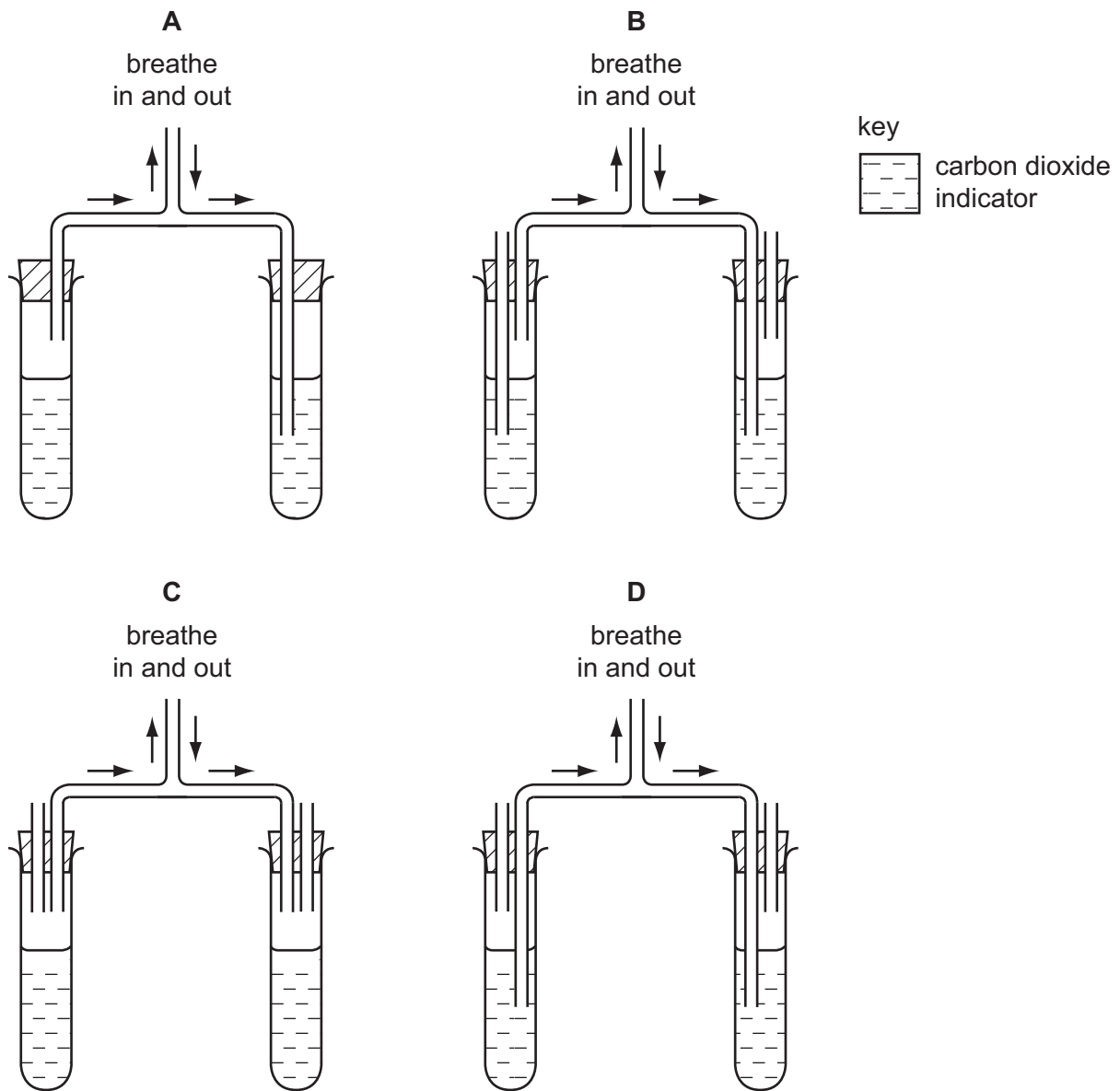

- 6 A person accidentally touches a very hot object with their hand.

What identifies the receptor, the speed of response and the type of response?

	receptor	speed of response	type of response
A	skin	rapid	nervous
B	muscle	slow	hormonal
C	eye	rapid	hormonal
D	brain	slow	nervous

7 The diagram shows an external view of the human heart.

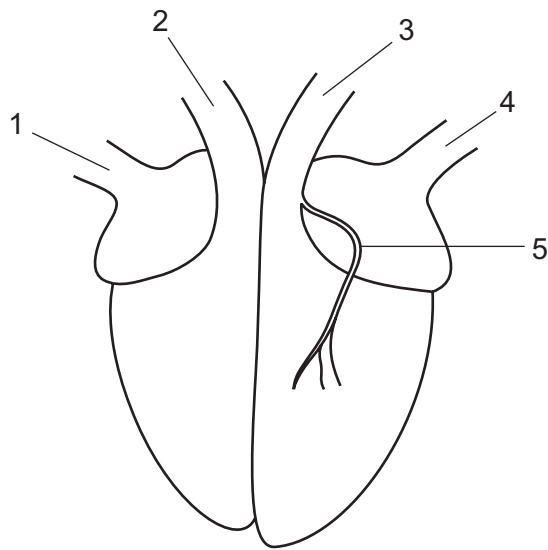

Which vessels contain oxygenated blood?

- A** 1, 2 and 4 **B** 1, 3 and 4 **C** 2, 3 and 5 **D** 3, 4 and 5

8 Water moves through the stomata of leaves during transpiration.

In which direction, and in which form, does it move?

	direction	form
A	into the leaf	liquid
B	into the leaf	vapour
C	out of the leaf	liquid
D	out of the leaf	vapour

- 9 The diagram shows a side view of the female reproductive system in a human.

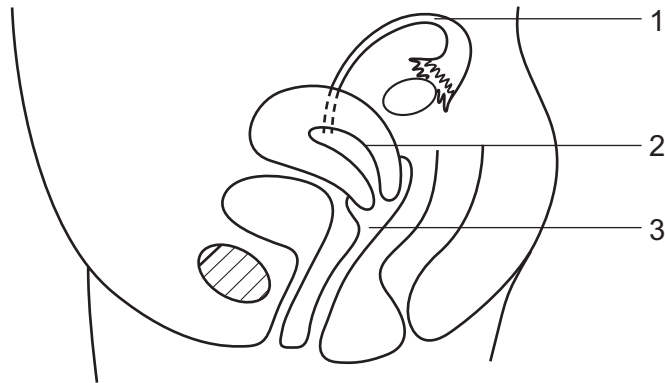

Where do fertilisation and implantation occur?

	fertilisation	implantation
A	1	2
B	2	1
C	2	3
D	3	2

- 10 Which structure in a flower produces pollen?

- A** sepal
- B** stamen
- C** stigma
- D** style

- 11 A gardener uses only asexual reproduction to produce clones of a flowering plant. The original plant had red flowers but some cloned plants had blue flowers.

What explains this change in flower colour?

- A** height of plant
- B** insect pollination
- C** variation caused by genes
- D** variation caused by the environment

12 The diagram represents a feeding relationship through which energy flows.



What is the type of the feeding relationship and the direction in which the energy flows?

	type of relationship	direction of energy flow
A	food chain	P to Q
B	food chain	Q to P
C	food web	P to Q
D	food web	Q to P

13 Which farming practice increases species diversity?

- A** cutting down trees
- B** grazing more cattle
- C** maintaining plant cover
- D** using tractors

14 Which diagram shows how a mixture of dyes in a food colouring can be separated?

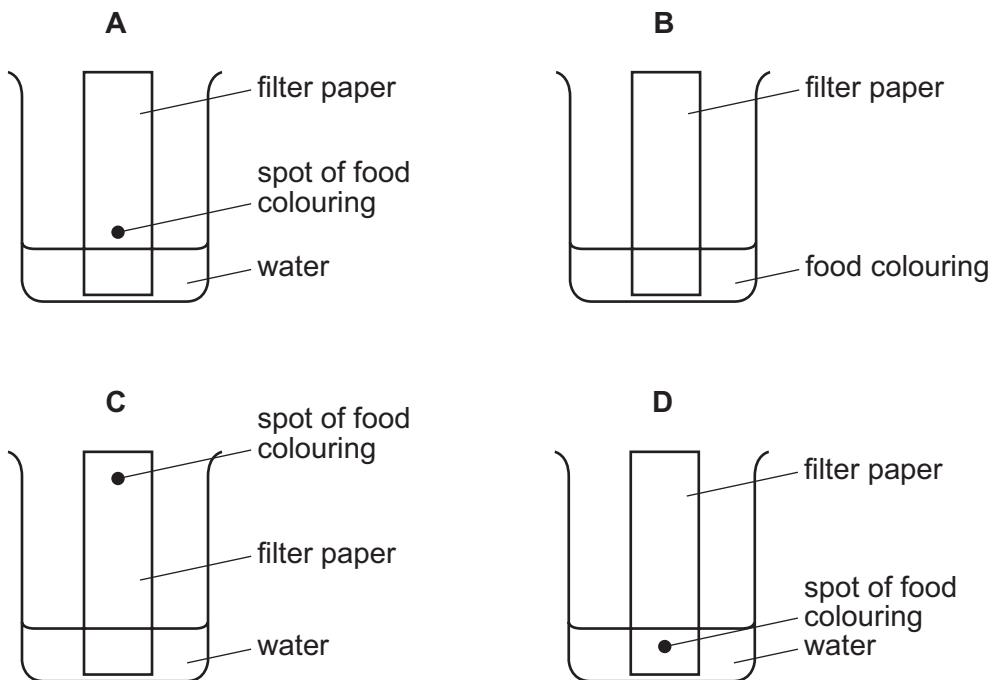

15 Which two elements form covalent bonds when they combine with each other?

- A calcium and oxygen
- B hydrogen and oxygen
- C magnesium and chlorine
- D sodium and chlorine

16 The symbols, nucleon numbers and proton numbers of three elements are shown.



A student is asked to write the nucleon number and proton number of another element.

Using the Periodic Table, which two numbers are correct?

	nucleon number	proton number
A	18	11
B	18	12
C	23	11
D	47	23

17 Why are noble gases unreactive?

- A They have a complete outer shell of electrons.
- B They have an even number of electrons.
- C They have an even number of shells of electrons.
- D They have two electrons in the first shell.

18 Which elements exist as diatomic molecules?

	bromine	calcium	chlorine	magnesium
A	✓	x	x	✓
B	✓	x	✓	x
C	x	✓	✓	x
D	x	✓	x	✓

key

✓ correct

x not correct

19 Which method is used to obtain iron from iron(III) oxide?

- A combustion
- B electrolysis
- C reduction
- D thermal decomposition

20 The diagrams show an experiment.

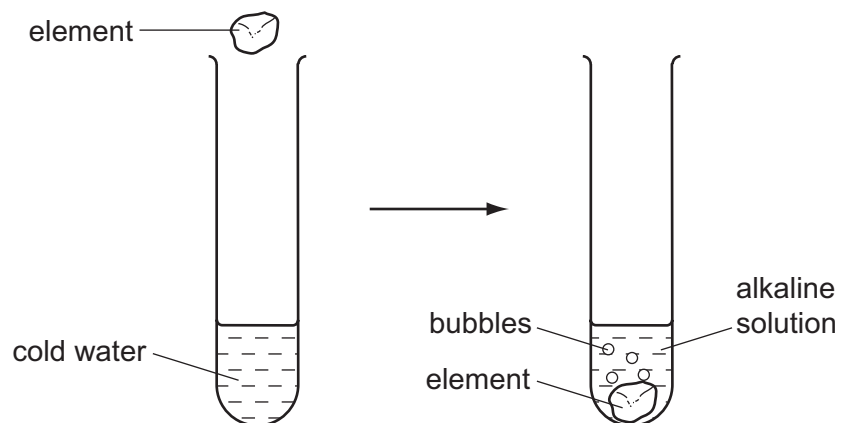

What could the element be?

- A calcium
- B carbon
- C copper
- D sulphur

21 The diagram shows uses of alloys.

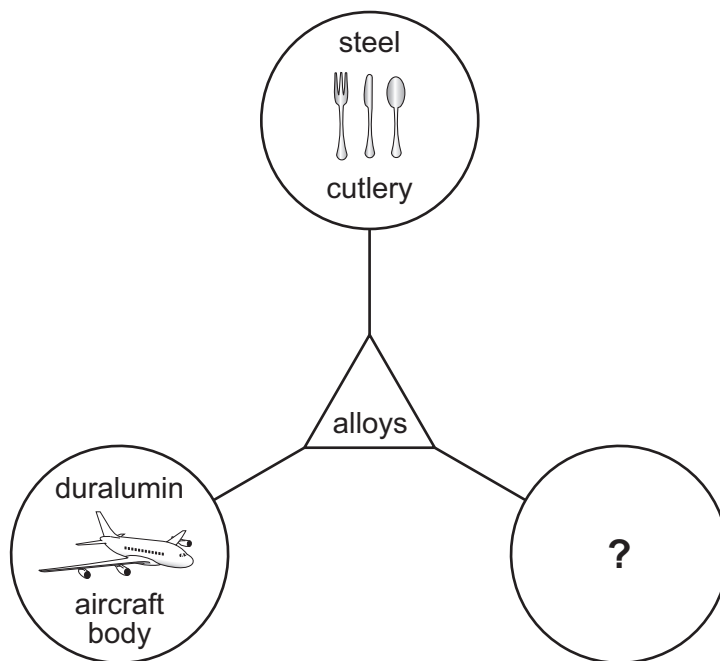

Which picture could be used to complete the diagram?

A	B	C	D

22 Which equation shows the thermal decomposition of a compound?

- A** $\text{CaCO}_3 \rightarrow \text{CaO} + \text{CO}_2$
- B** $2\text{H}_2 + \text{O}_2 \rightarrow 2\text{H}_2\text{O}$
- C** $\text{NaOH} + \text{HNO}_3 \rightarrow \text{NaNO}_3 + 2\text{H}_2\text{O}$
- D** $3\text{H}_2 + \text{N}_2 \rightarrow 2\text{NH}_3$

23 Marble and chalk are two forms of calcium carbonate.

The diagram shows equal masses of lumps of marble and powdered chalk placed in dilute hydrochloric acid.

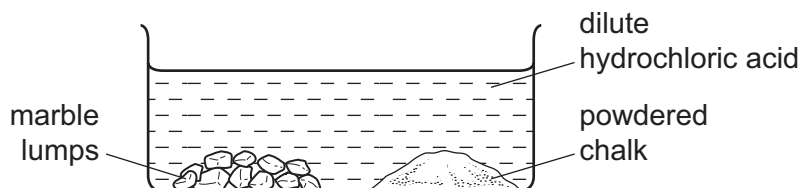

The marble takes longer than the chalk to dissolve in the acid.

Why is this?

- A Marble is more reactive than chalk.
- B Marble is more soluble than chalk.
- C The marble has the smaller surface area.
- D The marble is more basic.

24 The diagrams show the results of adding an excess of

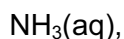
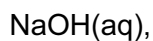

to a solution of salt S.

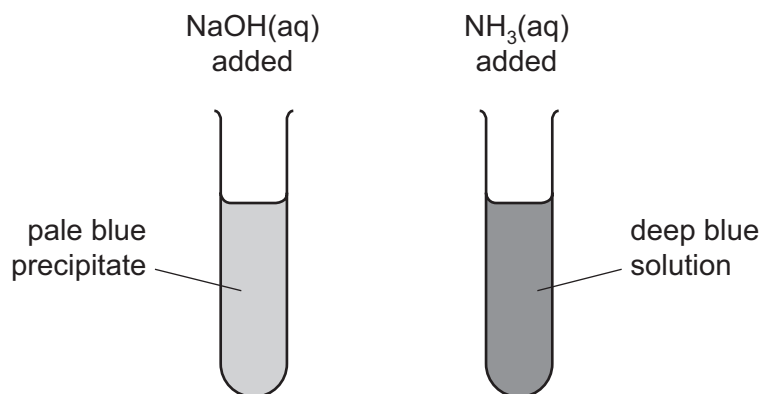

Which metal ion is present in salt S?

- A Cu^{2+}
- B Fe^{2+}
- C Fe^{3+}
- D Zn^{2+}

25 Which substance is reduced during the following reaction?

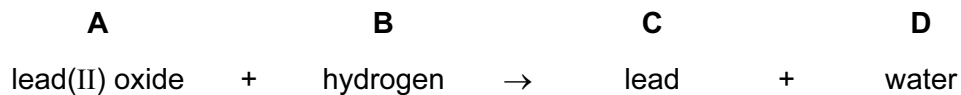

26 The diagrams show models of two molecules found in crude oil.

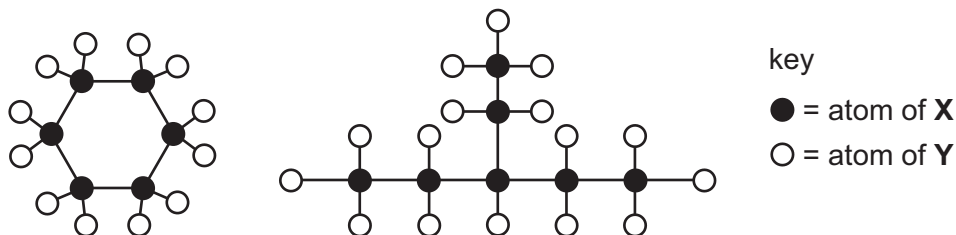

Which element could X be?

- A carbon
- B hydrogen
- C nitrogen
- D oxygen

27 The reaction shown occurs naturally.

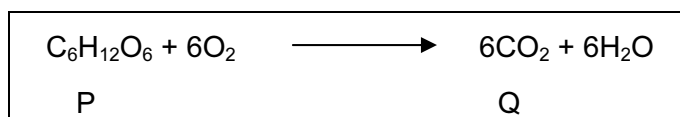

Which descriptions of P and Q are correct?

	P is a hydrocarbon	Q is an acidic oxide
A	yes	yes
B	yes	no
C	no	yes
D	no	no

28 The diagram shows a bird in flight.

In which direction does the weight of the bird act?

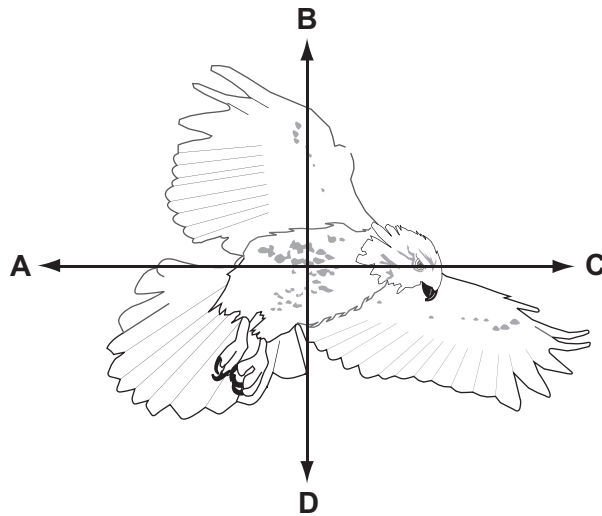

29 Which of the following is a unit of density?

- A** cm^3/g **B** g/cm^2 **C** g/cm^3 **D** kg/m^2

30 Each of the solids shown in the diagram has the same mass.

Which solid has the greatest density?

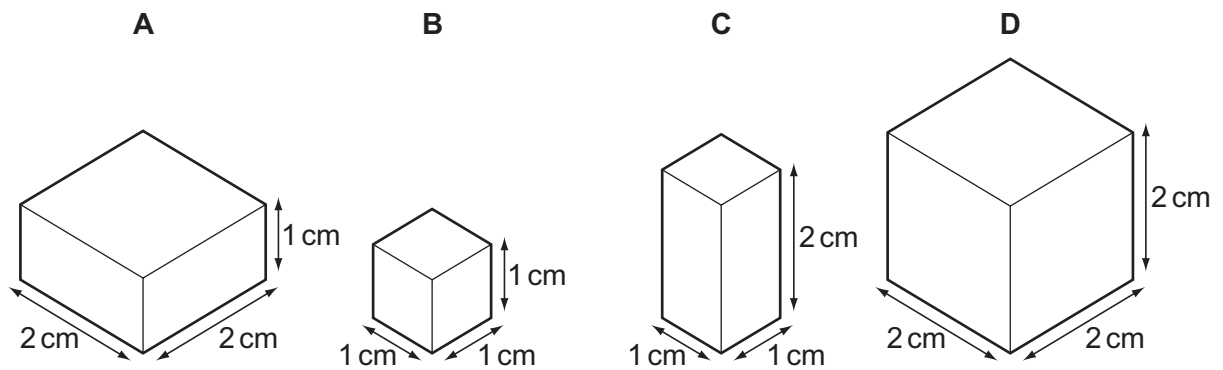

- 31 Meat can be cooked by placing it below, but not touching, a heating element.

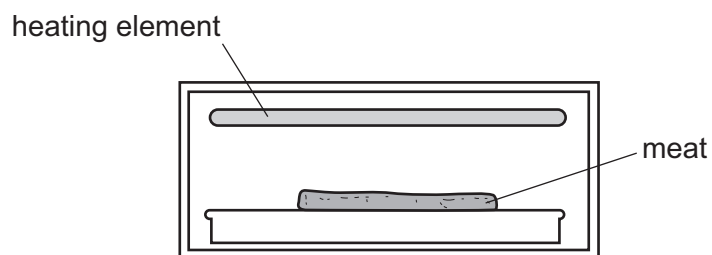

Which process transfers thermal energy from the heating element to the meat?

- A conduction
 - B convection
 - C insulation
 - D radiation
- 32 The diagram shows a refrigerator. The cooling unit is placed at the top. The cooling unit cools the air near it.

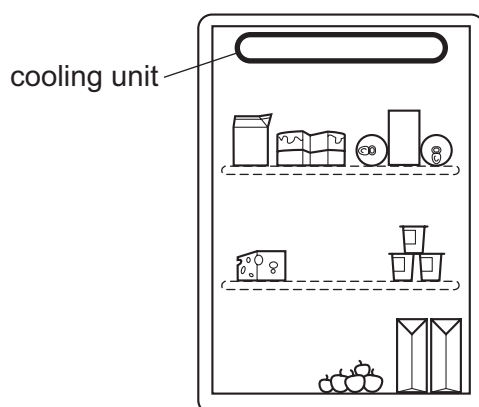

What happens to the density of this air as it cools and how does it move?

	density of the air	movement of the air
A	decreases	moves down
B	decreases	stays where it is
C	increases	moves down
D	increases	stays where it is

33 A man sees a stone at the bottom of a pool of water.

Which path could be taken by light from the stone to the man?

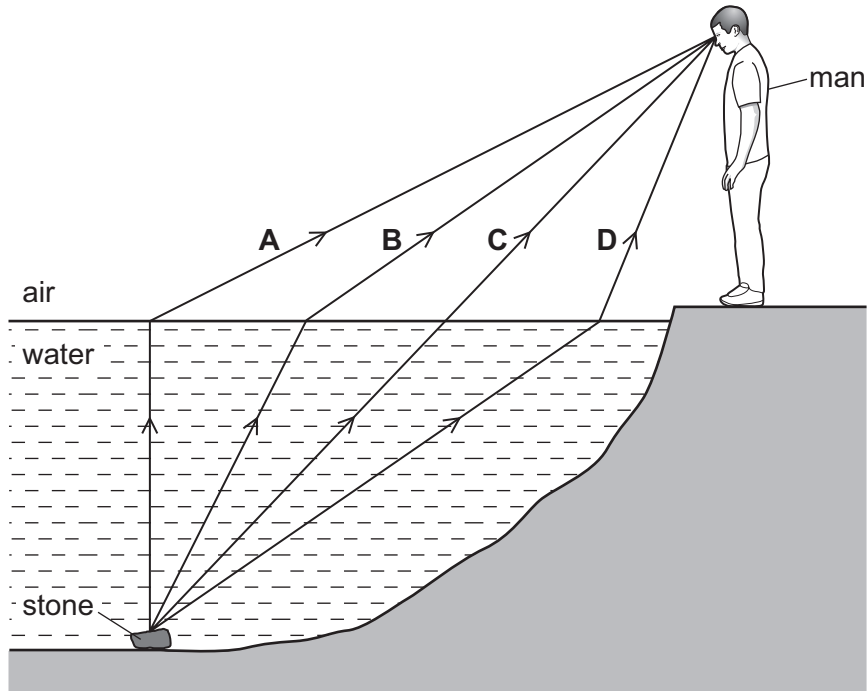

34 A ray of light is reflected by two parallel plane mirrors X and Y.

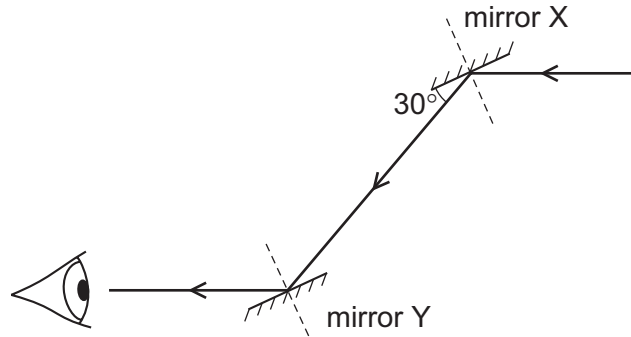

Which statement is correct?

- A The angle of incidence at mirror X is 30° .
- B The angle of incidence at mirror Y is 60° .
- C The angle of reflection at mirror X is 120° .
- D The angle of reflection at mirror Y is 0° .

35 A starting pistol is fired 640 m away from a spectator.

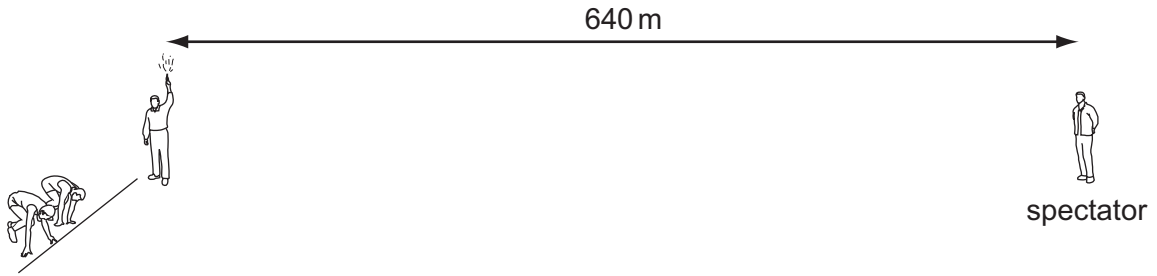

The spectator hears the sound of the starting pistol two seconds after seeing the flash.

What is the speed of sound in air?

- A 160 m/s B 320 m/s C 640 m/s D 1280 m/s

36 Which circuit shows the correct use of a voltmeter in measuring the p.d. across the resistor?

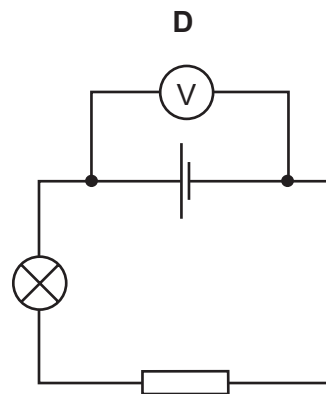
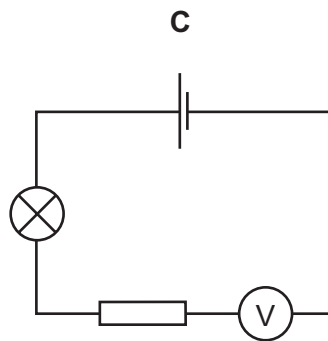
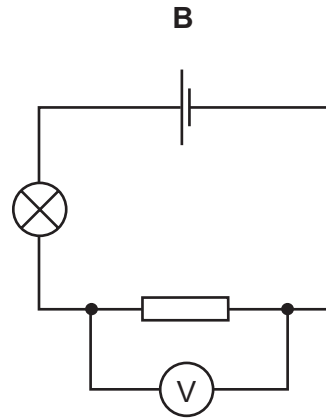
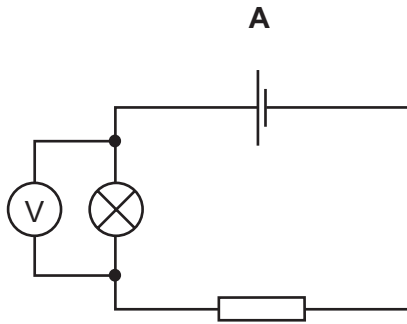

37 Which diagram shows a circuit that will allow the lamps to be switched on and off independently?

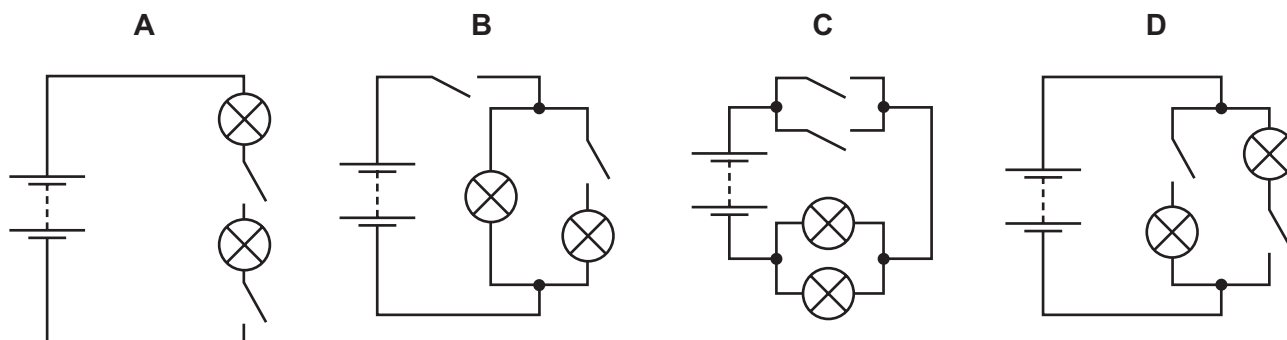

38 A cable in a house is carrying too much current.

What is the greatest danger?

- A appliances not working
- B electric shock
- C fire
- D low power

39 The diagram shows a lamp connected to a transformer.

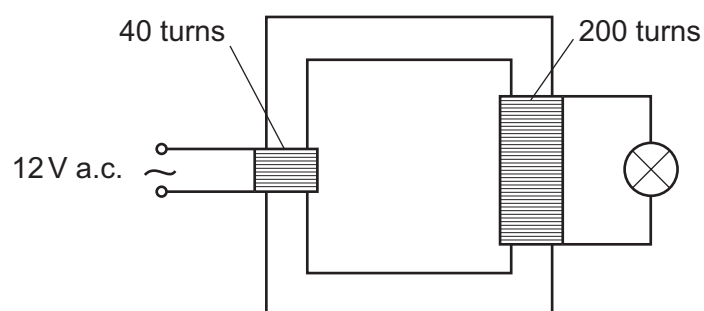

What is the potential difference across the lamp?

- A 2.4V
- B 12V
- C 60V
- D 240V

40 What are the most penetrating and the least penetrating types of radiation?

	most penetrating	least penetrating
A	alpha-particles	beta-particles
B	beta-particles	alpha-particles
C	gamma-rays	alpha-particles
D	gamma-rays	beta-particles

BLANK PAGE

DATA SHEET
The Periodic Table of the Elements

		Group																										
I	II	III	IV	V	VI	VII	0																					
		1 H Hydrogen 1									4 He Helium 2																	
7 Li Lithium 3	9 Be Beryllium 4											20 Ne Neon 10																
23 Na Sodium 11	24 Mg Magnesium 12	27 Al Aluminium 13	28 Si Silicon 14	31 P Phosphorus 15	32 S Sulphur 16	35.5 Cl Chlorine 17	40 Ar Argon 18																					
39 K Potassium 19	40 Ca Calcium 20	48 Ti Titanium 22	51 V Vanadium 23	55 Mn Manganese 25	56 Fe Iron 26	59 Co Cobalt 27	59 Ni Nickel 28	64 Cu Copper 29	65 Zn Zinc 30	70 Ga Gallium 31	73 Ge Germanium 32	75 As Arsenic 33	79 Se Selenium 34	80 Br Bromine 35	84 Kr Krypton 36													
85 Rb Rubidium 37	88 Sr Strontium 38	91 Zr Zirconium 40	93 Nb Niobium 41	96 Mo Molybdenum 42	101 Ru Ruthenium 44	103 Rh Rhodium 45	106 Pd Palladium 46	108 Ag Silver 47	112 Cd Cadmium 48	115 In Indium 49	119 Sn Tin 50	122 Sb Antimony 51	128 Te Tellurium 52	127 I Iodine 53	131 Xe Xenon 54													
133 Cs Caesium 55	137 Ba Barium 56	178 Hf Hafnium 72	181 Ta Tantalum 73	184 W Tungsten 74	186 Re Rhenium 75	190 Os Osmium 76	195 Pt Platinum 78	197 Au Gold 79	201 Hg Mercury 80	204 Tl Thallium 81	207 Pb Lead 82	209 Bi Bismuth 83	210 Po Polonium 84	210 At Astatine 85	222 Rn Radon 86													
226 Fr Francium 87	226 Ra Radium 88	227 Ac Actinium 89											227 Ac Actinium 89															
		*58-71 Lanthanoid series †90-103 Actinoid series										175 Lu Lutetium 71																
		140 Ce Cerium 58	141 Pr Praseodymium 59	144 Nd Neodymium 60	144 Pm Promethium 61	150 Sm Samarium 62	152 Eu Europium 63	157 Gd Gadolinium 64	159 Tb Terbium 65	162 Dy Dysprosium 66	165 Ho Holmium 67	167 Er Erbium 68	169 Tm Thulium 69	173 Yb Ytterbium 70	232 Th Thorium 90	232 Pa Protactinium 91	238 U Uranium 92	238 Np Neptunium 93	238 Pu Plutonium 94	238 Am Americium 95	238 Cm Curium 96	238 Bk Berkelium 97	238 Cf Californium 98	238 Es Einsteinium 99	238 Fm Fermium 100	238 Md Mendelevium 101	238 No Nobelium 102	238 Lr Lawrencium 103

a = relative atomic mass

X = atomic symbol

b = proton (atomic) number

Key

a	X	b
---	----------	---

The volume of one mole of any gas is 24 dm³ at room temperature and pressure (r.t.p.).