

|               |                  |      |
|---------------|------------------|------|
| Centre Number | Candidate Number | Name |
|---------------|------------------|------|

UNIVERSITY OF CAMBRIDGE INTERNATIONAL EXAMINATIONS  
International General Certificate of Secondary Education

**COMBINED SCIENCE**

**0653/05**

Paper 5 Practical Test

October/November 2004

**1 hour 30 minutes**

Candidates answer on the Question Paper.

Additional Materials: As listed in Instructions to Supervisors

**READ THESE INSTRUCTIONS FIRST**

Write your Centre number, candidate number and name on all the work you hand in.  
Write in dark blue or black pen in the spaces provided on the Question Paper.  
You may use a soft pencil for any diagrams, graphs or rough working.  
Do not use staples, paper clips, highlighters, glue or correction fluid.

Answer **all** questions.

At the end of the examination, fasten all your work securely together.

The number of marks is given in brackets [ ] at the end of each question or part question.

Chemistry practical notes for this paper are printed on page 12.

If you have been given a label, look at the details. If any details are incorrect or missing, please fill in your correct details in the space given at the top of this page.

Stick your personal label here, if provided.

**For Examiner's Use**

|              |  |
|--------------|--|
| 1            |  |
| 2            |  |
| 3            |  |
| <b>Total</b> |  |

This document consists of **9** printed pages and **3** blank pages.



- 1 This experiment is to find out how the enzyme catalase is affected by changing temperature. Catalase is released from potato cells when they are cut open. The enzyme speeds up the production of oxygen from hydrogen peroxide.

**Take care when using hydrogen peroxide. If it gets onto your skin or in your eyes wash it off immediately with cold water.**

- (a) • Set up your apparatus as shown in the diagram, Fig. 1.1.

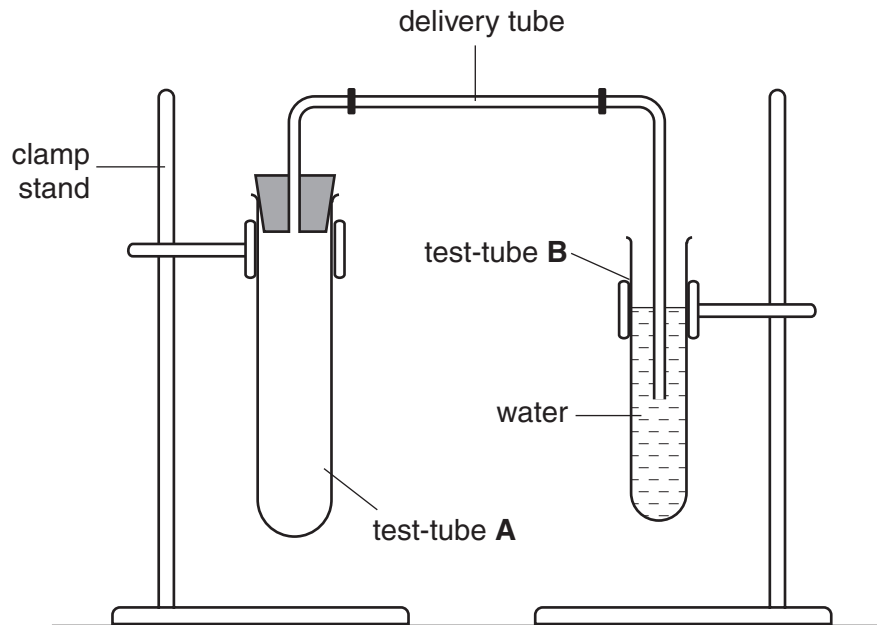

**Fig. 1.1**

- Remove the bung and delivery tube from test-tube **A** and pour  $10\text{ cm}^3$  hydrogen peroxide into it.
- Measure the temperature of the hydrogen peroxide in the tube and record it in the first line of the table, Fig. 1.2.
- Cut five pieces of potato measuring  $2.0\text{ cm} \times 1.0\text{ cm} \times 1.0\text{ cm}$  to the nearest millimetre.
- Put one piece of potato into the hydrogen peroxide, replace the bung firmly in the top of tube **A**, and immediately start timing.
- The oxygen produced will appear as bubbles in test-tube **B**. Wait for 30 seconds to allow the rate of reaction to become steady, then count the number of bubbles produced during the next two minutes. Record the number in Fig. 1.2.
- Rinse out test-tube **A**.
- Pour  $10\text{ cm}^3$  fresh hydrogen peroxide into tube **A** and put a thermometer into the tube.
- Warm the test-tube in a water bath until the temperature reads  $35^\circ\text{C}$ , then remove the thermometer and put tube **A** back in place ready for the next reading.

- Add a piece of potato, start timing and counting bubbles as before. Record your result in Fig. 1.2.
- Repeat the experiment at 45 °C, 55 °C and 60 °C.
- Complete the last column of the table.

| temperature/°C | number of bubbles counted in two minutes | number of bubbles per minute |
|----------------|------------------------------------------|------------------------------|
|                |                                          |                              |
| 35             |                                          |                              |
| 45             |                                          |                              |
| 55             |                                          |                              |
| 60             |                                          |                              |

[3]

Fig. 1.2

(b) Plot the **number of bubbles per minute** (vertical axis) against **temperature** on the grid.

number of  
bubbles per  
minute

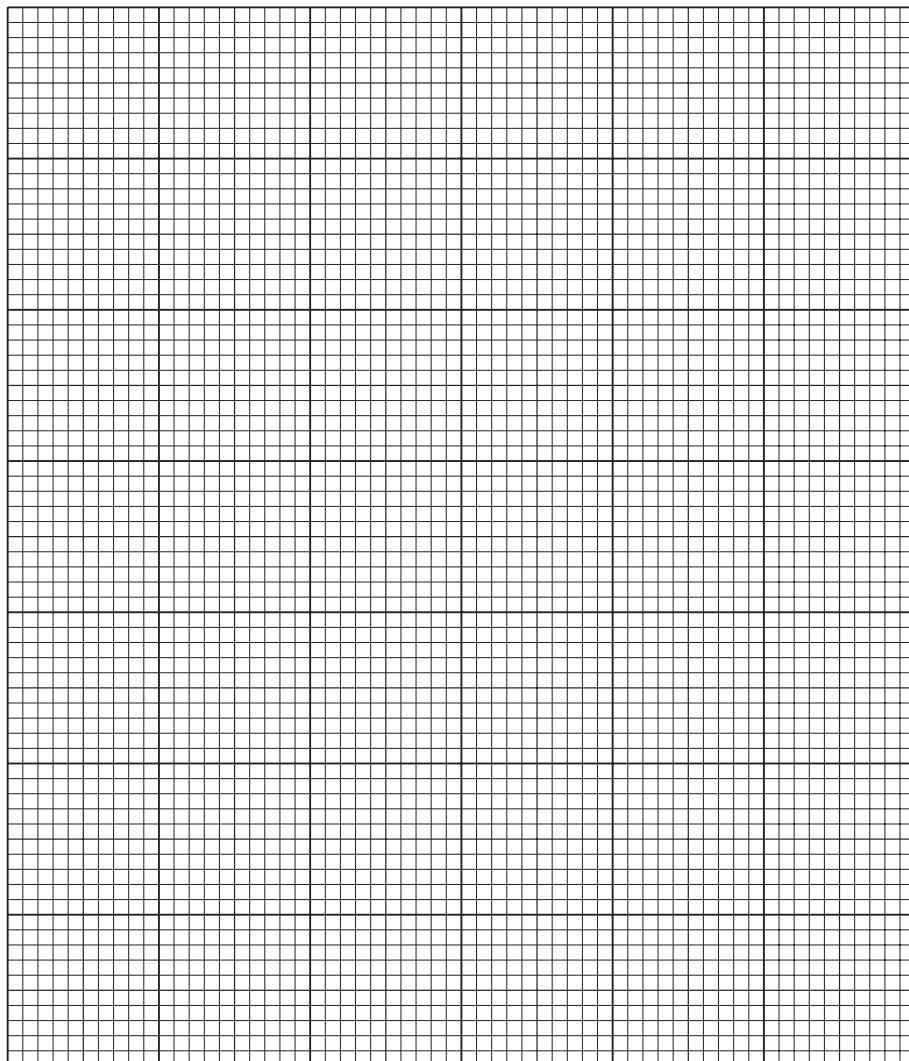

temperature / °C

[3]

(c) Explain the shape of your graph using your knowledge of enzyme action.

.....  
.....  
.....  
.....[2]

(d) (i) State **one** way you could improve the experiment to make it more accurate.

.....  
.....

(ii) Explain why your improvement would work.

.....  
.....[2]

**BLANK PAGE**

2 You are required to find the focal length of the lens provided and then use this value to investigate the type of image produced when an object is placed at different distances from the lens.

- (a) (i) Using plasticine, fix the lens at the 50 cm mark of the metre rule and move the screen, arranged as shown in Fig. 2.1, until a sharp image of an object at the other side of the room, such as a window, is obtained on the screen. Measure and record the distance  $f_1$  between the lens and the screen.

$f_1 = \dots\dots\dots$ mm

- (ii) Place the lens at the 40 cm mark and repeat the experiment. Record your result in the space below.

$f_2 = \dots\dots\dots$ mm

Calculate the average value for the focal length,  $F$ , of the lens.

average value for focal length,  $F = \dots\dots\dots$ mm

[2]

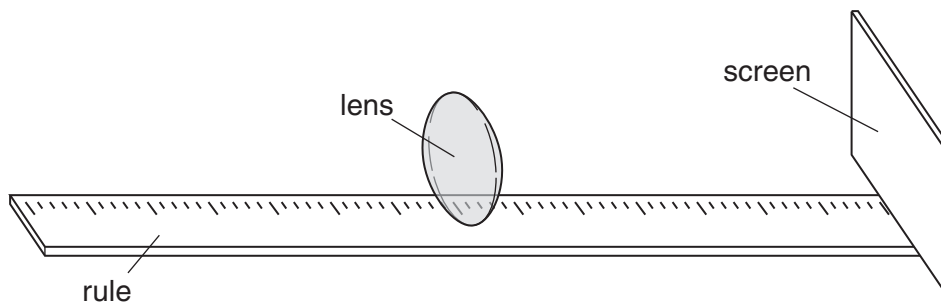

Fig. 2.1

- (b) (i)

- Using plasticine, fix the lens at the 50 cm mark of the metre rule.
- Place a small piece of plasticine on the rule at the point  $F$  mm from the lens on each side. See Fig. 2.2
- Place a small piece of plasticine on the rule at the point  $2F$  mm from the lens on each side. See Fig. 2.2
- Place the lighted candle (the object), on the rule beyond  $2F$  mm. See Fig. 2.2
- Move the screen, on the other side of the lens from the object, to obtain a sharp image of the candle flame on the screen.
- Record in Fig. 2.3 the position of the image, whether it is larger, smaller or the same size as the object, and whether it is upright or inverted.

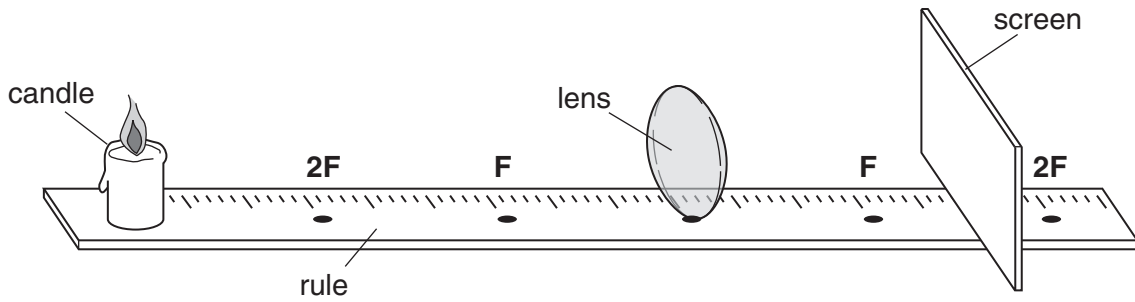

Fig. 2.2

| object position | image position | larger, smaller or same size | upright or inverted |
|-----------------|----------------|------------------------------|---------------------|
| beyond 2F       |                |                              |                     |
| at 2F           |                |                              |                     |

Fig. 2.3

- (ii) Repeat the experiment with the object **at 2F**. Record your observations in Fig. 2.3 as before. [6]
- (c) You are now required to complete the diagram, Fig. 2.4, as described and make measurements as instructed.

Draw a horizontal line from the top of the vertical line **D** to meet the lens. Label this point on the lens, **E**.

Now draw a straight line from **F<sub>2</sub>** through **E** and beyond.

Draw another straight line from **C** to touch the top of the line **D**. These two straight lines should meet beyond **F<sub>1</sub>**.

Measure and record the vertical distance from the line **AB** to where these two lines meet.

distance = .....mm [2]

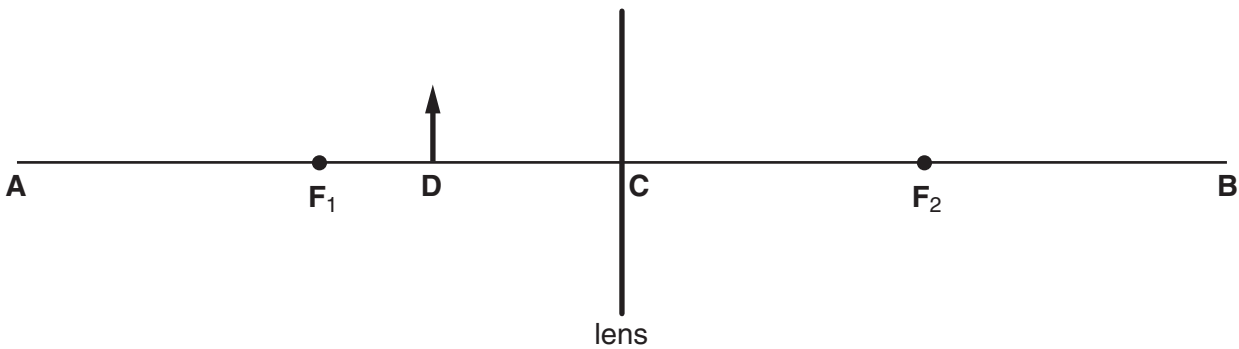

Fig. 2.4

- 3 You are required to find out how the rate of the reaction between hydrochloric acid and magnesium changes with the concentration of the hydrochloric acid.

**P** is a solution of hydrochloric acid, concentration  $2.0 \text{ mol/dm}^3$ .

- (a)
- Place  $80 \text{ cm}^3$  of solution **P** in a beaker.
  - Cut a  $2.0 \text{ cm}$  strip of magnesium.
  - Drop the magnesium into solution **P** and start the clock.
  - Find the time taken in seconds, for the magnesium to disappear. Record this time in Fig. 3.1.

| volume of solution <b>P</b> / $\text{cm}^3$ | volume of water/ $\text{cm}^3$ | concentration of acid in $\text{mol/dm}^3$ | time taken for magnesium to dissolve/s |
|---------------------------------------------|--------------------------------|--------------------------------------------|----------------------------------------|
| 80                                          | 0                              | 2.0                                        |                                        |
| 60                                          | 20                             | 1.5                                        |                                        |
| 40                                          | 40                             | 1.0                                        |                                        |
| 20                                          | 60                             | 0.5                                        |                                        |

**Fig. 3.1**

- (b) Repeat the experiment three more times, using a different concentration of hydrochloric acid each time. The different concentrations are prepared by mixing amounts of solution **P** and water shown in Fig. 3.1. Find the time taken for the magnesium to disappear for each experiment and record it in Fig. 3.1.

[6]



- (c) (i) Plot a graph of time (vertical axis) against the concentration of hydrochloric acid.

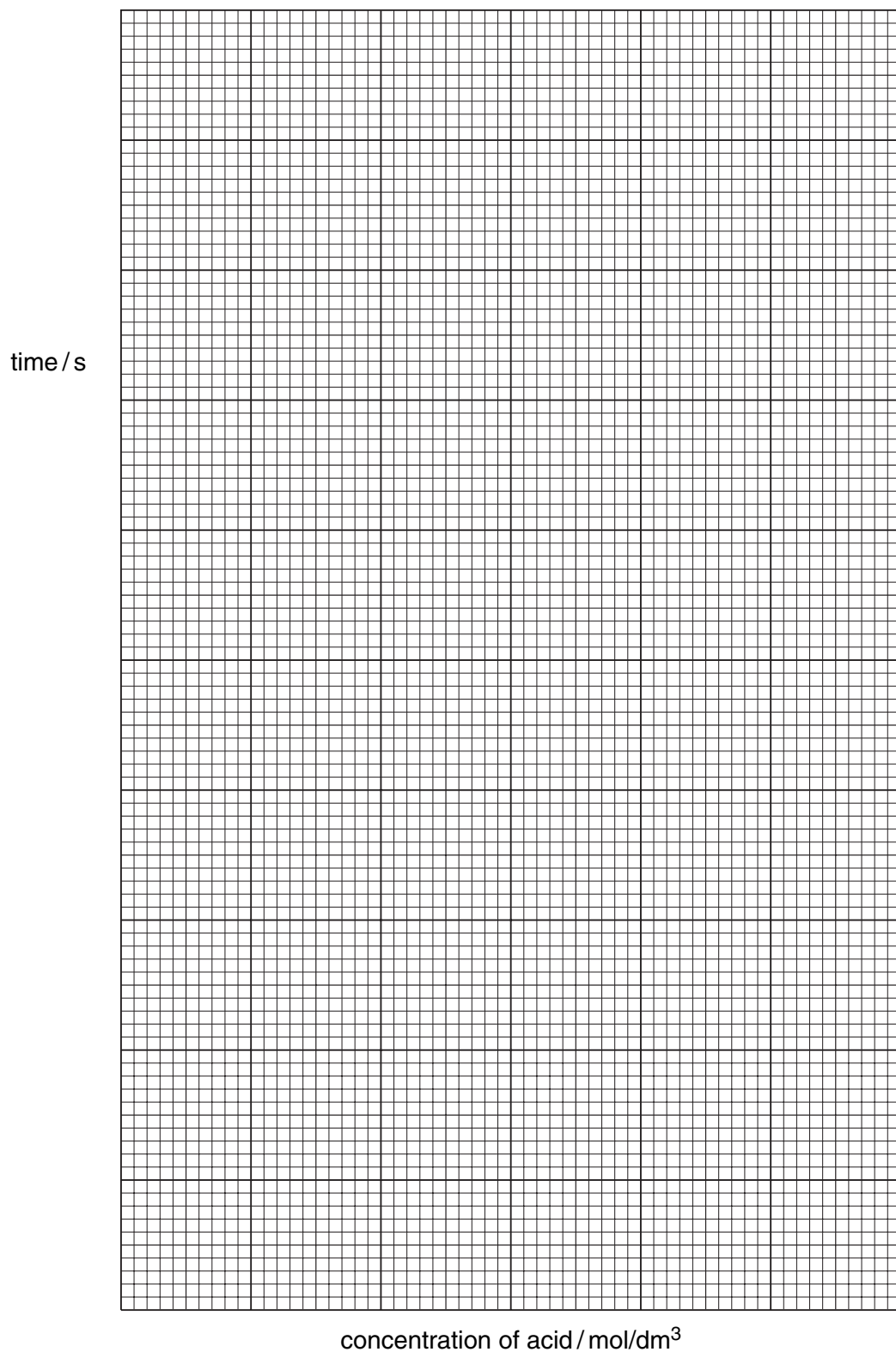

[3]

- (ii) Use your graph to predict the time taken using a concentration of 1.2 mol/dm<sup>3</sup>.

time taken = .....s

[1]





## CHEMISTRY PRACTICAL NOTES

## Test for anions

| <i>anion</i>                                     | <i>test</i>                                                                | <i>test result</i>                     |
|--------------------------------------------------|----------------------------------------------------------------------------|----------------------------------------|
| carbonate ( $\text{CO}_3^{2-}$ )                 | add dilute acid                                                            | effervescence, carbon dioxide produced |
| chloride ( $\text{Cl}^-$ )<br>[in solution]      | acidify with dilute nitric acid, then add aqueous silver nitrate           | white ppt.                             |
| nitrate ( $\text{NO}_3^-$ )<br>[in solution]     | add aqueous sodium hydroxide, then aluminium foil; warm carefully          | ammonia produced                       |
| sulphate ( $\text{SO}_4^{2-}$ )<br>[in solution] | acidify, then add aqueous barium chloride <i>or</i> aqueous barium nitrate | white ppt.                             |

## Test for aqueous cations

| <i>cation</i>                   | <i>effect of aqueous sodium hydroxide</i>                   | <i>effect of aqueous ammonia</i>                                |
|---------------------------------|-------------------------------------------------------------|-----------------------------------------------------------------|
| ammonium ( $\text{NH}_4^+$ )    | ammonia produced on warming                                 | –                                                               |
| copper(II) ( $\text{Cu}^{2+}$ ) | light blue ppt., insoluble in excess                        | light blue ppt., soluble in excess, giving a dark blue solution |
| iron(II) ( $\text{Fe}^{2+}$ )   | green ppt., insoluble in excess                             | green ppt., insoluble in excess                                 |
| iron(III) ( $\text{Fe}^{3+}$ )  | red-brown ppt., insoluble in excess                         | red-brown ppt., insoluble in excess                             |
| zinc ( $\text{Zn}^{2+}$ )       | white ppt., soluble in excess, giving a colourless solution | white ppt., soluble in excess, giving a colourless solution     |

## Test for gases

| <i>gas</i>                       | <i>test and test result</i>  |
|----------------------------------|------------------------------|
| ammonia ( $\text{NH}_3$ )        | turns damp litmus paper blue |
| carbon dioxide ( $\text{CO}_2$ ) | turns limewater milky        |
| chlorine ( $\text{Cl}_2$ )       | bleaches damp litmus paper   |
| hydrogen ( $\text{H}_2$ )        | 'pops' with a lighted splint |
| oxygen ( $\text{O}_2$ )          | relights a glowing splint    |