

CANDIDATE
NAME

--

CENTRE
NUMBER

--	--	--	--	--

CANDIDATE
NUMBER

--	--	--	--

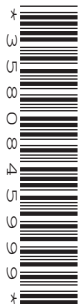

BIOLOGY

0610/42

Paper 4 Theory (Extended)

October/November 2018

1 hour 15 minutes

Candidates answer on the Question Paper.

No Additional Materials are required.

READ THESE INSTRUCTIONS FIRST

Write your Centre number, candidate number and name on all the work you hand in.

Write in dark blue or black pen.

You may use a pencil for any diagrams or graphs.

Do not use staples, paper clips, glue or correction fluid.

DO NOT WRITE IN ANY BARCODES.

Answer **all** questions.

Electronic calculators may be used.

You may lose marks if you do not show your working or if you do not use appropriate units.

At the end of the examination, fasten all your work securely together.

The number of marks is given in brackets [] at the end of each question or part question.

- 1 Wetlands are important ecosystems. Researchers studied the feeding relationships between the organisms in an area of wetland on the coast of Texas.

Fig. 1.1 shows part of the food web that they studied.

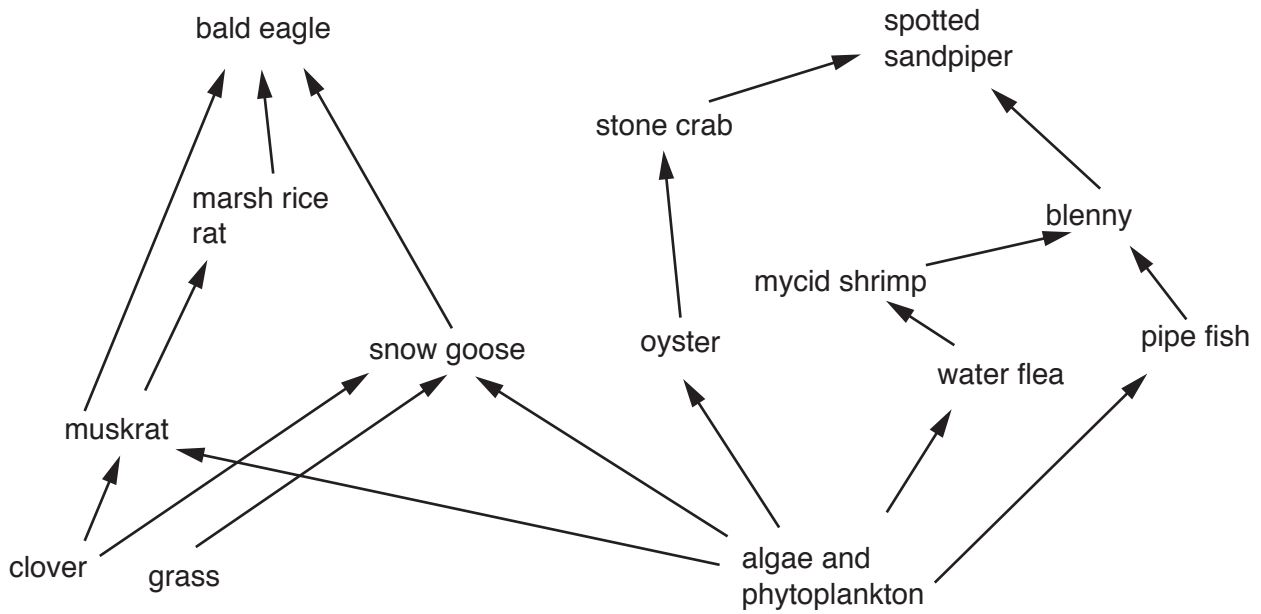

Fig. 1.1

- (a) Complete Table 1.1 by giving the name of **one** organism from the food web in Fig. 1.1 for each row.

Table 1.1

	name of organism from Fig. 1.1
producer	
secondary consumer	
an animal that feeds at two trophic levels	

[3]

The functioning of ecosystems relies on the cycling of nutrients.

Fig. 1.2 shows part of the nitrogen cycle.

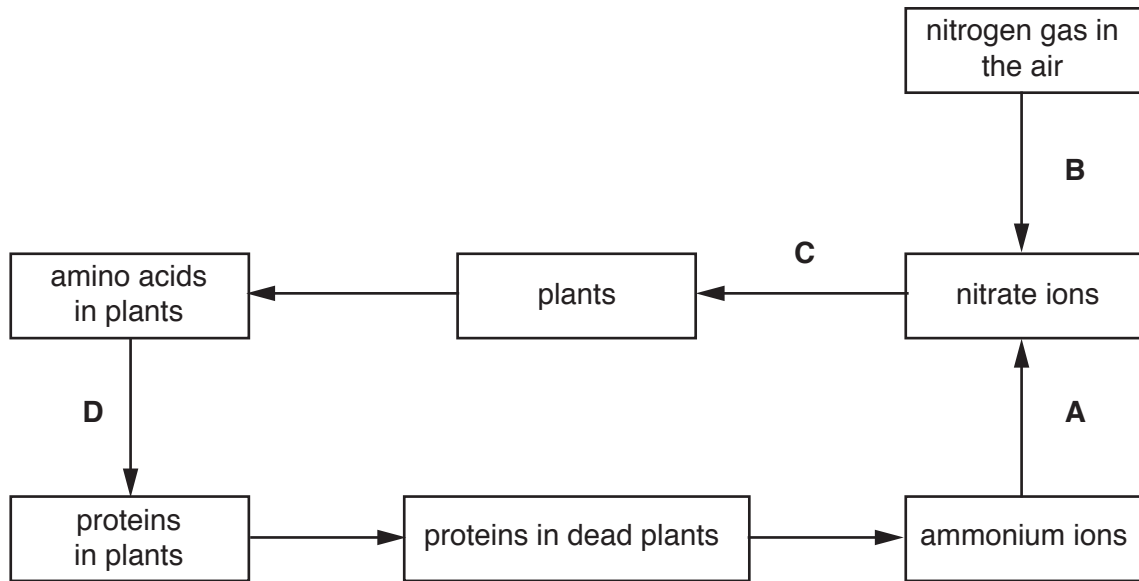

Fig. 1.2

(b) State the name of process **A** in Fig. 1.2 and give the type of organism that converts ammonium ions to nitrate ions.

A

type of organism

[2]

(c) Describe how nitrate ions enter the roots of plants shown by arrow **C** on Fig. 1.2.

.....

.....

.....

.....

.....

.....

.....

.....

.....

.....

[3]

(d) State the name of the structure in plant cells where process **D** occurs.

..... [1]

(e) State the process that occurs at **B**.

..... [1]

(f) A pyramid of numbers for the wetland ecosystem showed that there were very large numbers of organisms at the base of the pyramid and very few at the top.

Explain why.

.....
.....
.....
.....
.....
.....
.....
.....
.....
..... [3]

[Total: 13]

- 2 Fig. 2.1 shows a dwarf sunflower and a tall sunflower, *Helianthus annuus*. The height of the dwarf sunflower is 0.45 m and the height of the tall sunflower is 4.5 m.

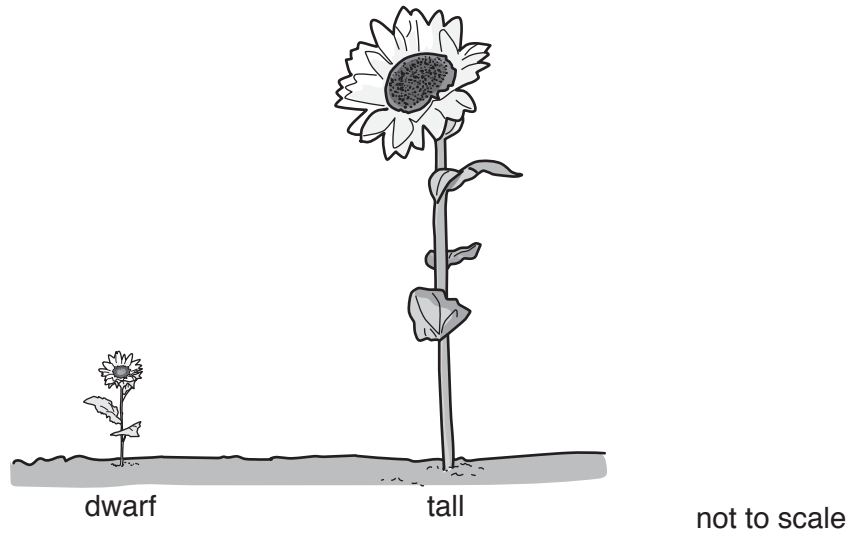

Fig. 2.1

Dwarf plants like the one in Fig. 2.1 have mutant alleles.

- (a) Define the term *allele*.

.....
..... [1]

- (b) Shoot growth in plants is controlled by auxins. An enzyme in shoot tips converts molecules of an amino acid into auxins as shown in Fig. 2.2.

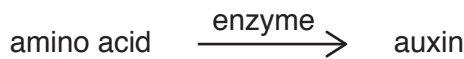

Fig. 2.2

Explain how a mutation in DNA results in an abnormal enzyme which does **not** catalyse the reaction shown in Fig. 2.2.

.....
.....
.....
.....
.....
.....
.....
.....
.....
..... [3]

(c) Two tall sunflower plants were crossed. 25% of the offspring produced were dwarf.

Explain how it is possible for two tall parent plants to have this percentage of dwarf offspring.

.....

.....

.....

.....

..... [2]

(d) Fig. 2.3 shows how several strawberry plants can be formed from one parent plant.

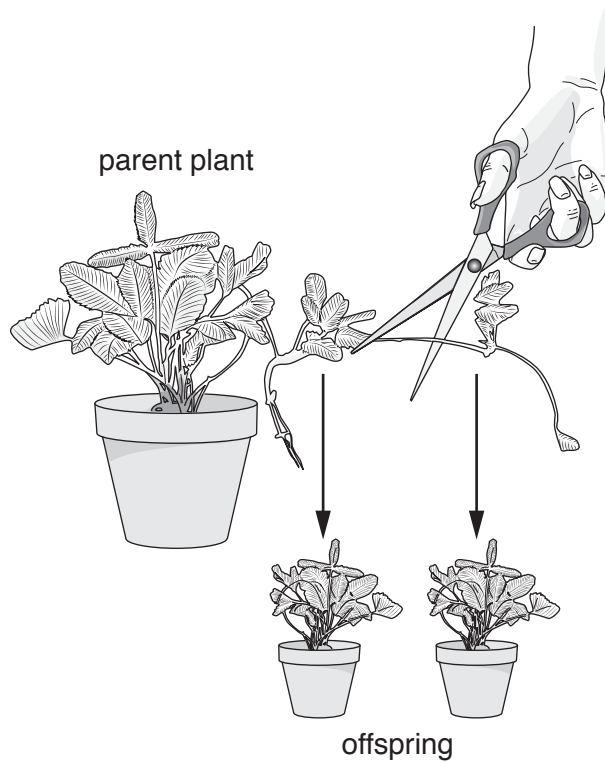

Fig. 2.3

(i) Explain the type of reproduction that produces plants by the method shown in Fig. 2.3.

.....

.....

.....

.....

.....

.....

..... [3]

(ii) Explain the **disadvantages** of the type of reproduction shown in Fig. 2.3.

.....

.....

.....

.....

.....

.....

.....

.....

..... [3]

[Total: 12]

3 (a) Fig. 3.1 is a photomicrograph of some xylem vessels.

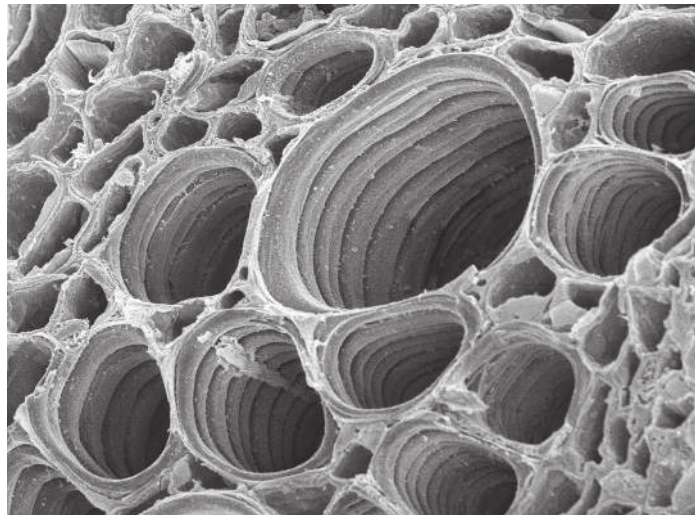

Fig. 3.1

(i) State **one** structural feature of xylem vessels and explain how this is related to the function of water transport.

feature

.....

explanation

.....

.....

.....

[2]

(ii) Explain the mechanism that is responsible for the movement of water in xylem vessels.

.....

.....

.....

.....

.....

.....

.....

.....

..... [4]

(iii) State **one** role of xylem vessels **other than** transport.

..... [1]

(b) The rate of transpiration is affected by several factors including the temperature and the humidity of the air.

State **and** explain the effect of an increase in temperature on the rate of transpiration.

.....

.....

.....

.....

.....

.....

.....

.....

.....

.....

.....

..... [3]

[Total: 10]

4 Insulin is a hormone that regulates the concentration of glucose in the blood.

(a) Define the term *hormone*.

.....

.....

.....

.....

.....

.....

..... [3]

(b) Two people, **A** and **B**, visited a doctor to discuss their similar symptoms. The doctor thought that their blood glucose concentrations were not very well controlled. A glucose tolerance test was carried out on both people.

A and **B** did not eat or drink anything other than water for eight hours before the test. They then drank a glucose solution. Blood samples were taken at 30 minute intervals. The samples were tested for glucose concentration.

The results are shown in Fig. 4.1.

blood glucose
concentration
/mg per 100cm³

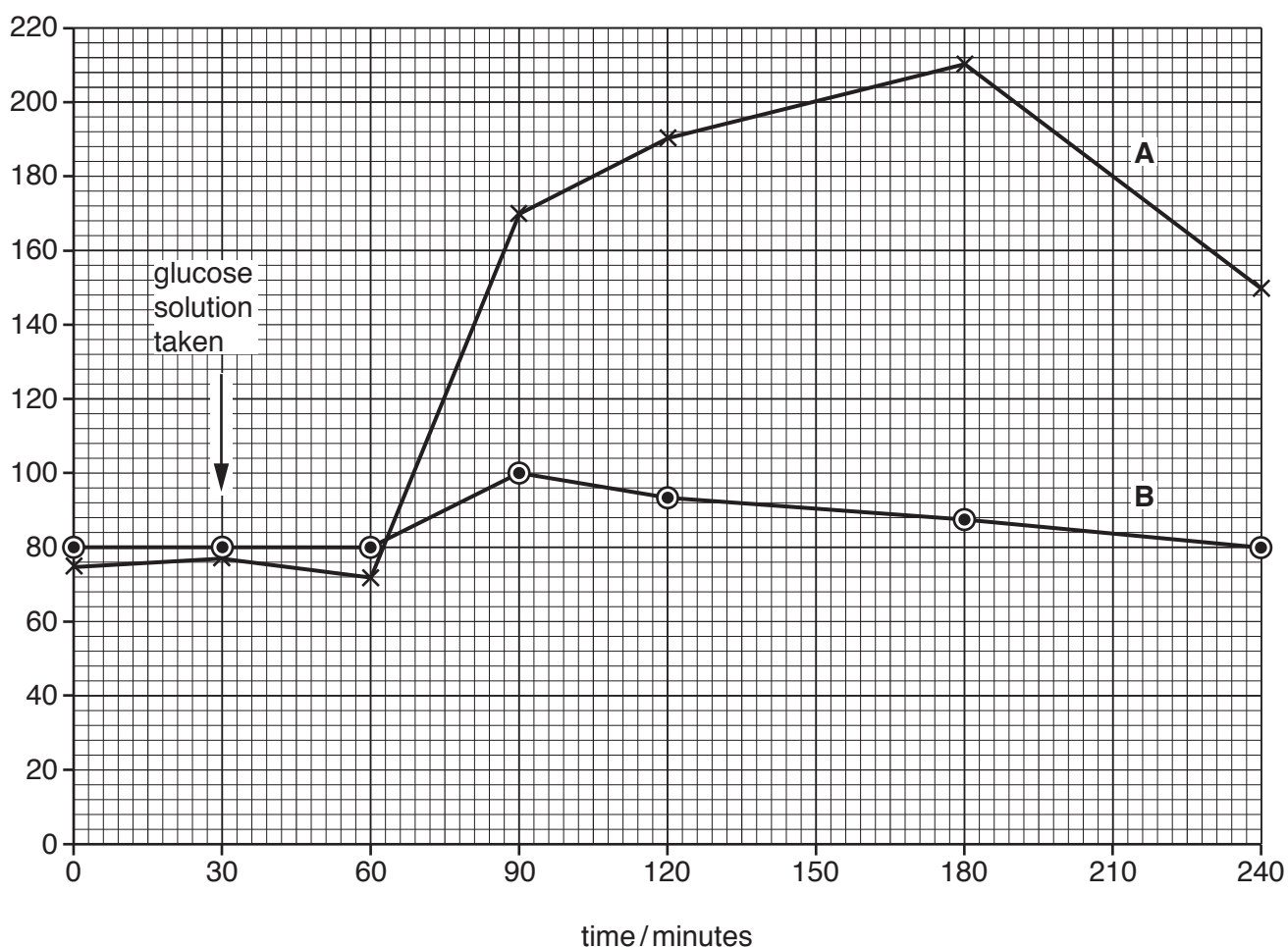

Fig. 4.1

(i) Use Fig. 4.1 to state the blood glucose concentrations of **A** and **B** at 180 minutes.

A mg per 100 cm³
B mg per 100 cm³
[1]

(ii) Calculate the percentage increase in the blood glucose concentration in person **A** between 60 and 90 minutes.

Give your answer to the nearest whole number.

Show your working.

..... %
[2]

(iii) Describe how the response of person **A** differs from the response of person **B** in Fig. 4.1.

.....
.....
.....
.....
..... [2]

(iv) Explain the results of the glucose tolerance test shown by person **B**.

.....
.....
.....
.....
.....
.....
.....
.....
.....
..... [4]

(v) The doctor thought that person **A** had Type 1 diabetes.

Describe **three** symptoms of Type 1 diabetes.

.....

.....

.....

.....

..... [3]

[Total: 15]

(b) Fig. 5.2 shows some of the stages of blood clotting.

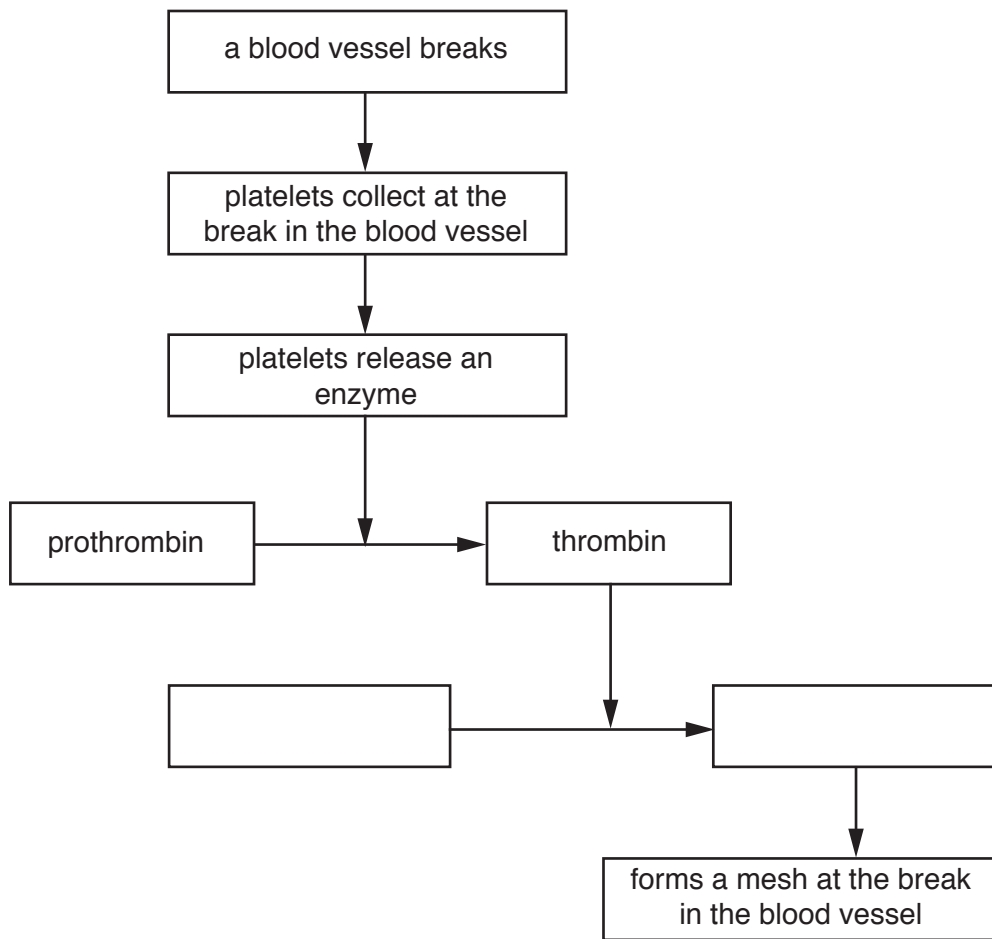

Fig. 5.2

(i) Complete Fig. 5.2 by filling in the **two** empty boxes. [1]

(ii) State **two** roles of blood clotting.

.....

.....

.....

.....

..... [2]

(c) Haemophilia is a sex-linked blood disorder in which blood takes a long time to clot. Fig. 5.3 is a pedigree diagram showing the inheritance of haemophilia.

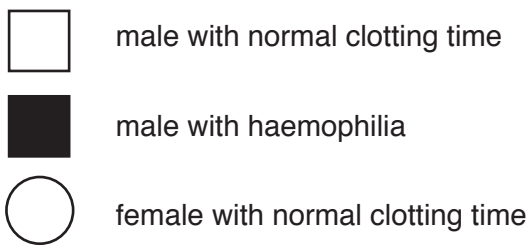
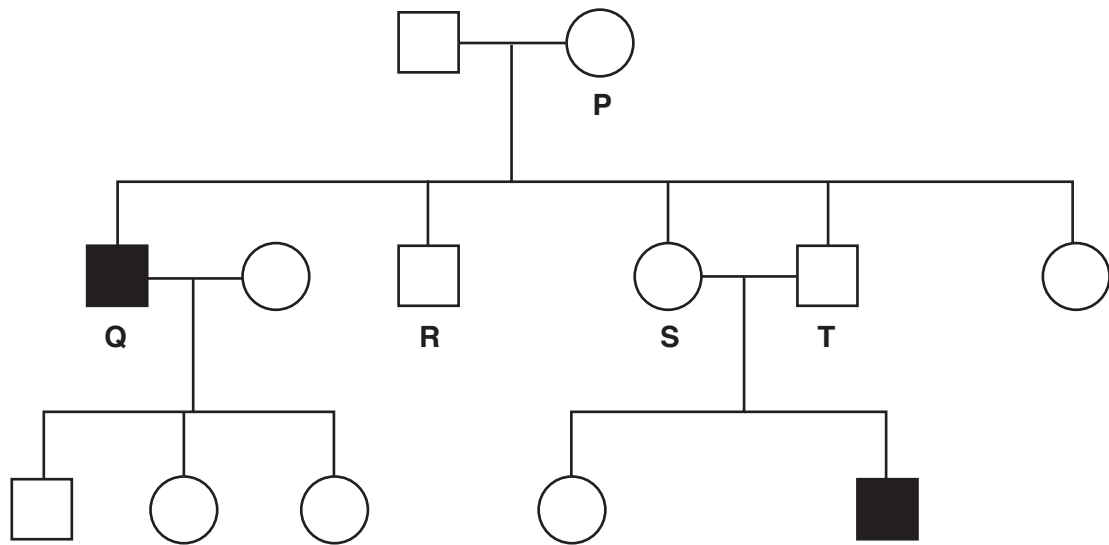

Fig. 5.3

The normal allele is represented by X^H and the mutant allele is represented by X^h .

(i) State the genotypes of the people identified as **P**, **Q** and **R** in Fig. 5.3.

P

Q

R

[3]

(ii) The couple **S** and **T** are expecting another child.

What is the probability that the child will have haemophilia?

Space for working

..... [1]

(iii) Define the term *sex-linked characteristic*.

.....
.....
.....
.....
.....
..... [2]

[Total: 15]

- 6 Fig. 6.1 shows the Galapagos iguana, *Amblyrhynchus cristatus*.



Fig. 6.1

- (a) (i) State **two** features that are used to classify animals, such as the Galapagos iguana, as reptiles.

1

2

[2]

- (ii) State **two** features that are present in plant cells that are **not** present in the cells of reptiles.

1

2

[2]

- (b) Galapagos iguanas feed on seaweed which contains starch and other carbohydrates.

- (i) State the name of the enzyme that digests starch.

..... [1]

- (ii) State the names of **two** parts of the alimentary canal where starch is digested.

1

2

[2]

