



UNIVERSITY OF CAMBRIDGE INTERNATIONAL EXAMINATIONS
International General Certificate of Secondary Education

CANDIDATE
NAME

CENTRE
NUMBER

--	--	--	--	--

CANDIDATE
NUMBER

--	--	--	--



TWENTY FIRST CENTURY SCIENCE

0608/04

Paper 4

May/June 2013

1 hour 30 minutes

Candidates answer on the Question Paper.

No Additional Materials are required.

READ THESE INSTRUCTIONS FIRST

Write your Centre number, candidate number and name on all the work you hand in.

Write in dark blue or black pen.

You may use a pencil for any diagrams or graphs.

Do not use staples, paper clips, highlighters, glue or correction fluid.

DO NOT WRITE IN ANY BARCODES.

Answer **all** questions.

Electronic calculators may be used.

At the end of the examination, fasten all your work securely together.

The number of marks is given in brackets [] at the end of each question or part question.

This document consists of **17** printed pages and **3** blank pages.



- 1 Scientists measure the nitrogen dioxide concentration in the air in a city centre. They take their measurements over a period of 24 hours. Their results are shown in the bar chart.

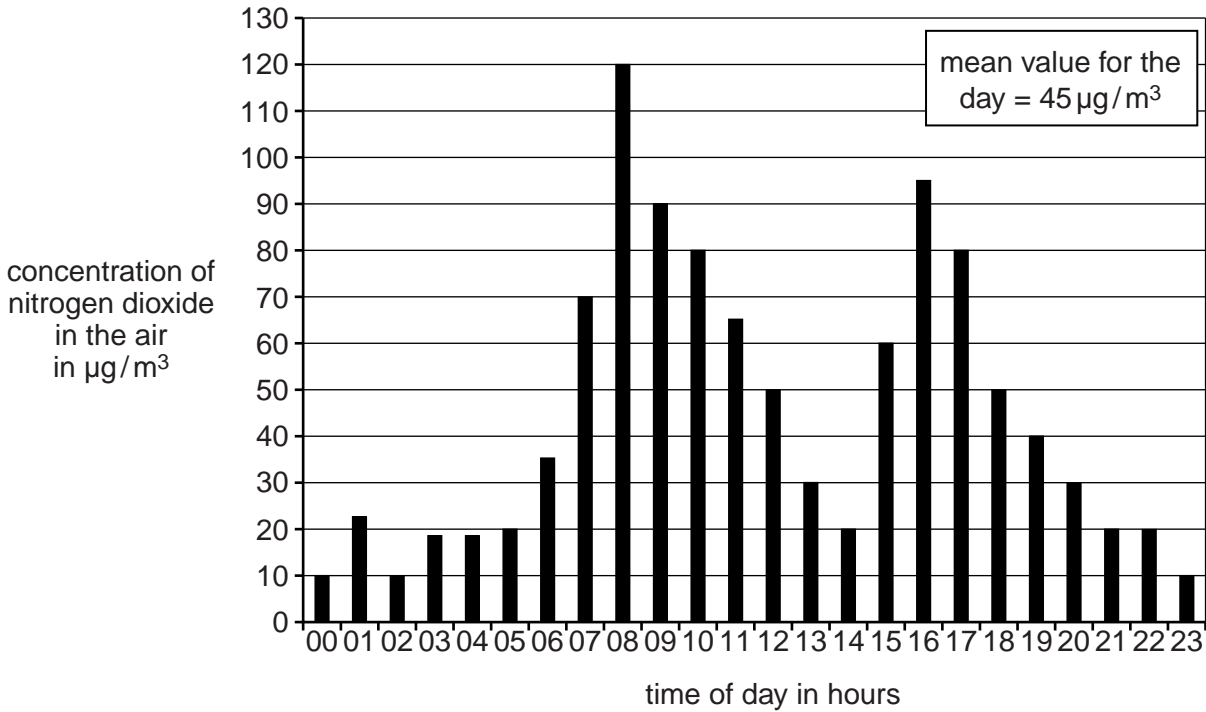

- (a) What is the range of the measurements taken by the scientists on this day?

range = from to µg/m³ [1]

- (b) The main source of nitrogen dioxide is from cars driving in the town.

Suggest why the concentration reaches two peak levels each day.

.....

 [2]

(c) The fumes from car engines contain nitrogen monoxide, but they cause the air to be polluted with nitrogen dioxide.

For
Examiner's
Use

(i) Describe how nitrogen monoxide is formed in car engines.

.....
.....
..... [2]

(ii) Explain how cars cause the air to be polluted with nitrogen dioxide.

.....
..... [1]

[Total: 6]

2 Fibres made from a new polymer are tested using the apparatus shown below.

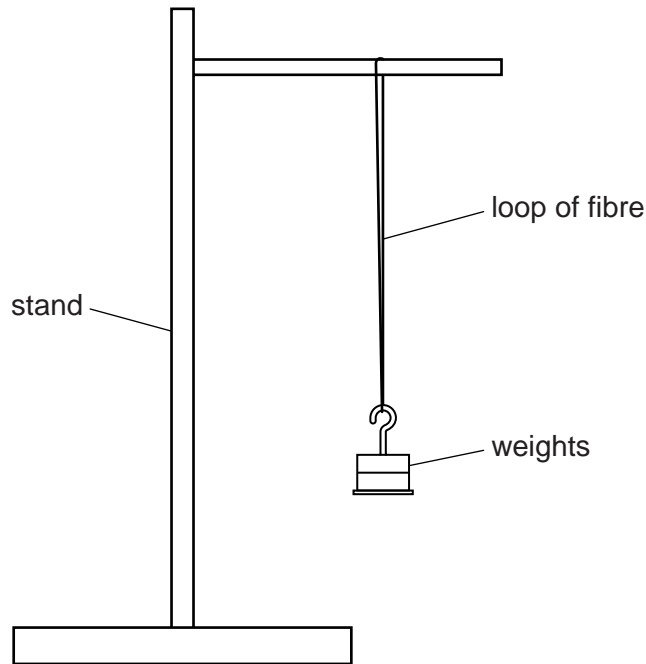

A 20 cm loop of fibre is stretched by adding weights one at a time.

The length of the loop is measured after each weight is added.

The length of the loop of fibre just before it breaks is written down. This is used to calculate how much the fibre has stretched.

The test is then repeated five more times and a best estimate is calculated.

(a) The same diameter of fibre is used for each test.

Explain why it is important to keep this variable constant.

.....

.....

.....

..... [2]

(b) Results of these tests on the new polymer are shown in Table 1.

For
Examiner's
Use

Table 1

sample number	1	2	3	4	5	6
stretch in mm	13	11	19	13	14	12

Show that the best estimate for the stretch of fibres made from the new polymer is 12.6 mm.

[1]

(c) A plasticiser is added to the new polymer.

Fibres of the plasticised polymer are then tested in the same way as the unplasticised polymer.

Results of these tests are shown in Table 2.

Table 2

sample number	1	2	3	4	5	6	best estimate
stretch in mm	21	20	22	21	23	22	21.5

(i) The results in Tables 1 and 2 show that there is a real difference between the properties of the fibres from the plasticised and unplasticised polymers.

Explain how they show a real difference.

.....

 [1]

(ii) Adding a plasticiser has changed the properties of the polymer.

Explain how the plasticiser caused this change in properties.

Use ideas about forces between molecules in your answer.

.....

.....

.....

.....[3]

[Total: 7]

For
Examiner's
Use

3 (a) Complete these sentences about the digestion of food.

During digestion large food molecules are broken down into small molecules.

Starch is broken down into

Protein is broken down into [1]

(b) Eating too much of some food types can lead to health problems. For example, eating too much sugar can lead to diabetes.

(i) The labels on many food packets give details of what is in the food.

A person could use this information to avoid the health problems that may be caused by eating too much of some food types.

Explain how.

.....
.....
..... [2]

(ii) A high sugar intake can lead to the development of diabetes.

Many people eat large quantities of foods that contain a lot of sugar.

Use ideas of risk and consequence to discuss whether they should or should not do this.

.....
.....
.....
..... [3]

(c) Obesity is also associated with the development of diabetes.

Use ideas about energy to explain why a person may become obese.

.....
..... [1]

[Total: 7]

4 This question is about near-Earth asteroids. These are asteroids with orbits which cross the Earth's orbit.

(a) Some astronomers spend a lot of time looking for near-Earth asteroids.

(i) Explain why it is important to discover near-Earth asteroids.

.....
.....
.....
.....[2]

(ii) Detecting near-Earth asteroids is difficult.

Suggest and explain why this is so.

.....
.....
.....
.....[2]

(b) The dinosaurs died out about 65 million years ago.

In 1980, scientists suggested that this happened when an asteroid crashed into the Earth. This idea was supported by asteroid dust found in rocks of that age.

In 1990, the remains of a large crater was discovered near Chicxulub, in Mexico. Evidence in the rocks suggested that this crater was about 65 million years old.

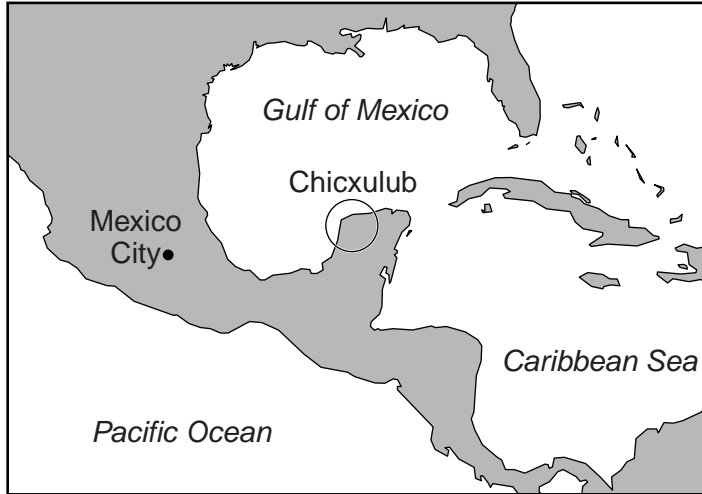

Explain why the discovery of this crater was important to the scientists developing the theory of extinction of dinosaurs.

.....

.....

..... [2]

[Total: 6]

5 (a) The table below shows how the mean surface temperature of the Earth changed between 1900 and 2000.

year	1900	1910	1920	1930	1940	1950	1960	1970	1980	1990	2000
mean surface temperature in °C	13.75	13.65	13.70	13.80	13.95	13.90	14.00	13.95	14.05	14.20	14.40

(i) Seven points from the data in the table have been plotted on the grid below.

Plot the remaining points.

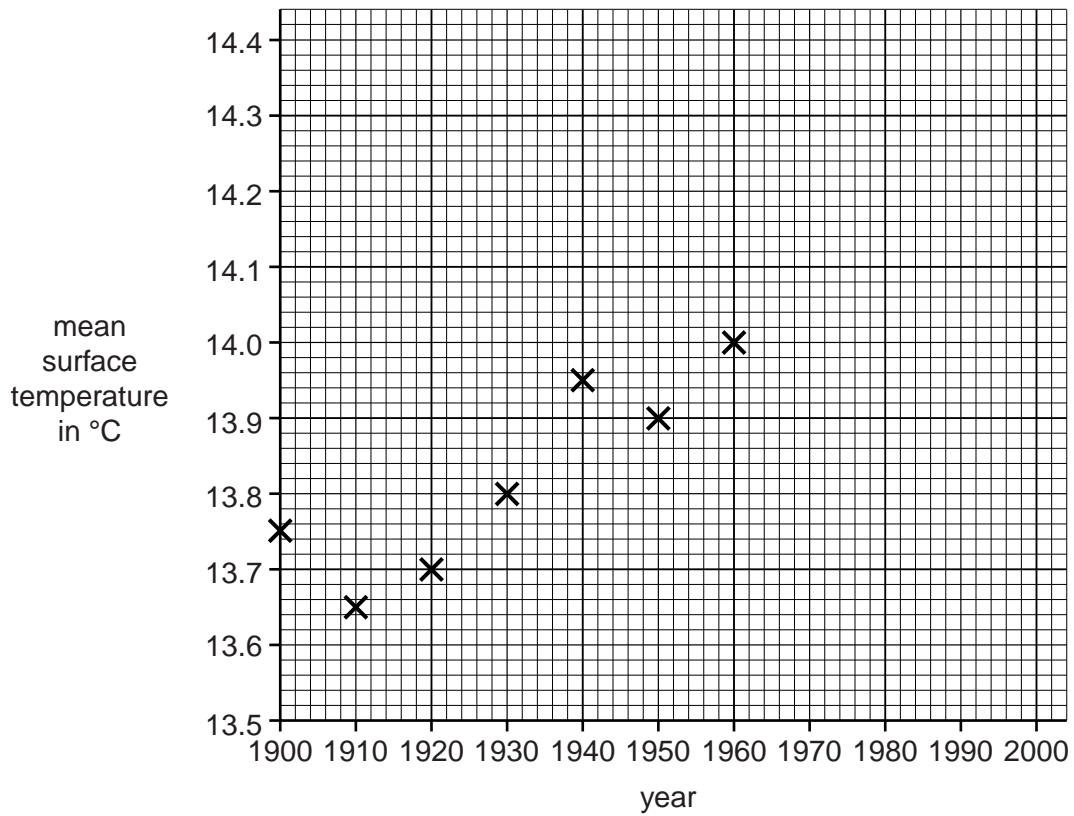

[2]

(ii) Draw a smooth best-fit curve through the data.

[1]

(b) Two scientists have different descriptions of the graph.



Dr Chang
The results show a definite trend. This is global warming.



Dr Hussein
The results are very variable. They do not show a definite trend.

(i) Write down a scientific explanation Dr Chang would give for the rise in temperature.

.....
.....
.....
.....
.....
.....
..... [3]

(ii) Dr Chang and Dr Hussein are both scientists.

Explain why they can have different interpretations of the graph.

.....
.....
..... [1]

[Total: 7]

6 Nuclear power stations produce radioactive waste.

(a) Radioactive waste must be processed before disposal.

There are plans to build a new waste processing plant.

Some people who live nearby are very worried about the possible risks.

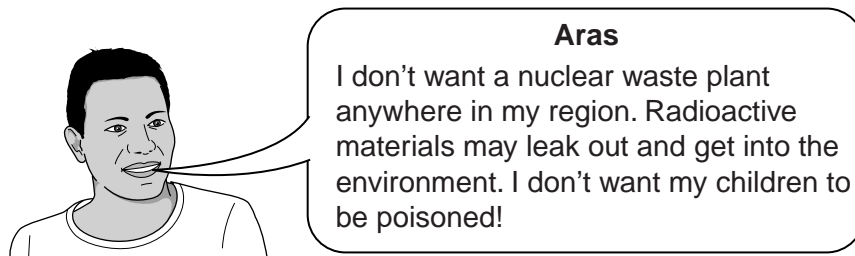

(i) Give one benefit of having the processing plant built in the region.

.....[1]

(ii) Give one way in which the risk could be kept as small as possible.

.....
.....[1]

(b) Radioactive waste becomes less active with time.

One part of the radioactive waste, plutonium, has a half-life of 24 000 years.

Calculate the time that the plutonium must be kept securely before its activity drops to one quarter of its initial value.

Show your working clearly.

time = years [2]

(c) The following table shows the properties of three different radioactive elements present in nuclear waste.

For
Examiner's
Use

element	radiation emitted	half-life in years
caesium-137	gamma	30
strontium-90	beta	29
americium-241	alpha	400

(i) Suggest and explain how you could tell which element was which if you were given a sample of each.

Use information from the table in your answer.

.....

.....

.....

.....

.....

..... [2]

(ii) The radioactive waste needs to be stored safely until it is no longer hazardous.

Both americium-241 and caesium-137 pose problems in storage.

Explain why.

americium-241

.....

caesium-137

..... [1]

[Total: 7]

7 A newborn baby cannot produce antibodies.

(a) A baby begins to make her own antibodies when she is about 12 weeks old.

Many babies are vaccinated at this age.

(i) Suggest why a baby is not usually vaccinated before 12 weeks.

.....
.....[1]

(ii) Parents are encouraged to get their babies vaccinated.

Explain why it is important that as many babies as possible are vaccinated.

.....
.....[1]

(iii) Some people think it should be compulsory for all babies to be vaccinated.

In many countries it is not compulsory to vaccinate all babies, even though it would be possible.

Suggest reasons why vaccination remains optional in these countries.

.....
.....
.....[2]

(b) The graph shows what happens to the concentration of antibodies in a baby's bloodstream after vaccination at time **A** and then after exposure to the disease at time **B**.

For
Examiner's
Use

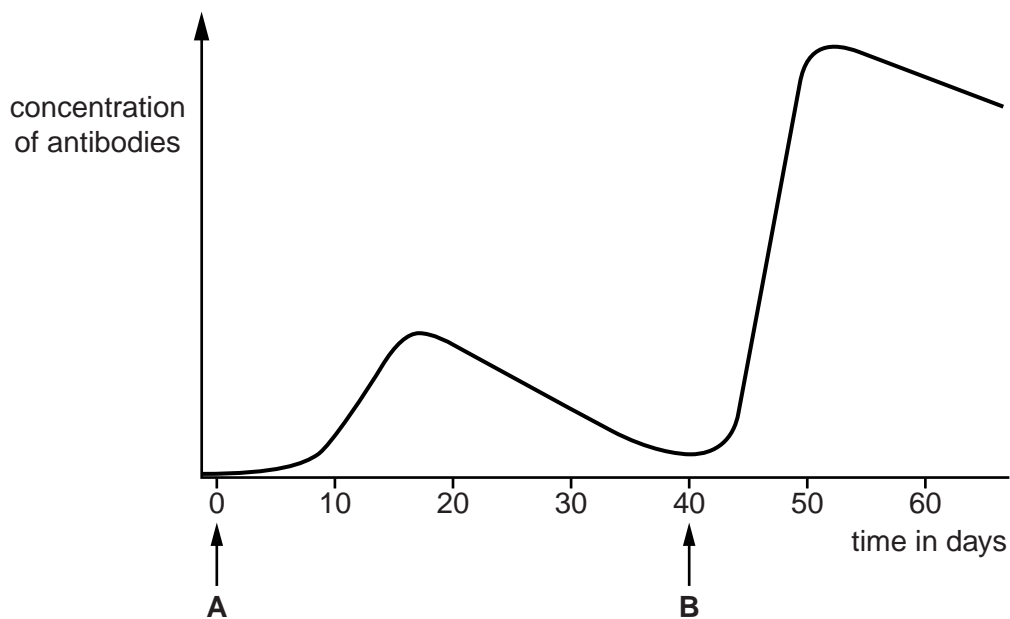

(i) **Describe** two differences between the increases in antibody concentration after the vaccination at time **A** and after exposure to the disease at time **B**.

.....
.....
.....
..... [2]

(ii) **Explain** these differences.

.....
.....
.....
..... [2]

[Total: 8]

8 Our bodies have communication systems that allow us to respond to changes in our environment.

For
Examiner's
Use

(a) (i) Write down **two** examples of **nervous** communication in humans.

.....

 [2]

(ii) The nervous system consists of nerve cells, receptor cells and effector cells.

Explain how these cells work together to respond to a stimulus.

.....

 [2]

(iii) The speed of nerve impulses is different in different animals.

Look at the table of data.

animal	speed of impulse in m/s	vertebrate or invertebrate
human	30.4	vertebrate
crab	6.4	invertebrate
frog	12.2	vertebrate
horse	18.3	vertebrate
lugworm	3.1	invertebrate

Write down a conclusion that can be made about the speed of impulses in vertebrate and invertebrate animals.

Use data in your answer to support your conclusion.

.....

 [2]

- (b) The effect of hormonal communication in humans is more widespread through the body than the effect of nervous communication.

Explain why.

.....

.....

..... [2]

[Total: 8]

- 9 Read the article about stem cells.

First stem cell trial in stroke patient

A British man has had stem cells injected into his brain to replace the cells damaged by a stroke. A stroke is a serious medical condition that occurs when the blood supply to part of the brain is cut off.

The stem cells used in this clinical trial were taken from embryos.

Many people support this step forward in the treatment of stroke patients. Others are worried about the ethical issues it raises.

- (a) Explain why stem cells can be used to replace damaged cells.

.....

.....

..... [2]

- (b) Stem cell therapy has the potential to save many lives. It may help to treat or cure some serious illnesses.

Despite this potential benefit of stem cell therapy, some people believe it should never be carried out.

Suggest two reasons why.

1

2 [2]

[Total: 4]

BLANK PAGE

Permission to reproduce items where third-party owned material protected by copyright is included has been sought and cleared where possible. Every reasonable effort has been made by the publisher (UCLES) to trace copyright holders, but if any items requiring clearance have unwittingly been included, the publisher will be pleased to make amends at the earliest possible opportunity.

University of Cambridge International Examinations is part of the Cambridge Assessment Group. Cambridge Assessment is the brand name of University of Cambridge Local Examinations Syndicate (UCLES), which is itself a department of the University of Cambridge.