



UNIVERSITY OF CAMBRIDGE INTERNATIONAL EXAMINATIONS
International General Certificate of Secondary Education

TWENTY FIRST CENTURY SCIENCE (EXTENDED)

0608/02

Paper 2 Multiple Choice

May/June 2013

1 hour

Additional Materials: Multiple Choice Answer Sheet
Soft clean eraser
Soft pencil (type B or HB is recommended)



READ THESE INSTRUCTIONS FIRST

Write in soft pencil.

Do not use staples, paper clips, highlighters, glue or correction fluid.

Write your name, Centre number and candidate number on the Answer Sheet in the spaces provided unless this has been done for you.

DO NOT WRITE IN ANY BARCODES.

There are **forty** questions on this paper. Answer **all** questions. For each question there are four possible answers **A, B, C** and **D**.

Choose the **one** you consider correct and record your choice in **soft pencil** on the separate Answer Sheet.

Read the instructions on the Answer Sheet very carefully.

Each correct answer will score one mark. A mark will not be deducted for a wrong answer.

Any rough working should be done in this booklet.

Electronic calculators may be used.

This document consists of **15** printed pages and **1** blank page.



1 Which statement best describes genes?

- A Genes are proteins found in cells.
- B Genes are sections of very long DNA molecules.
- C Genes are very long chromosomes.
- D Genes are very short DNA molecules.

2 The genetic diagram shows the inheritance of cystic fibrosis. Cystic fibrosis is a recessive condition.

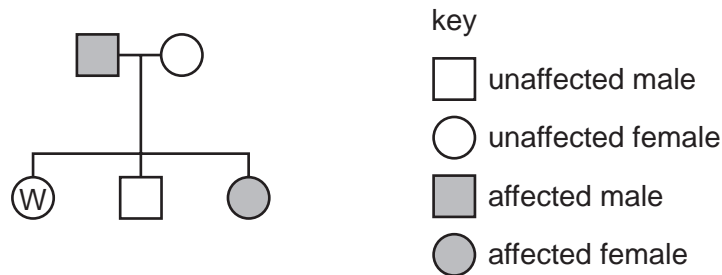

What are the chances of person W being a **carrier** for cystic fibrosis?

- A 0%
- B 33%
- C 50%
- D 100%

3 Women with the BRCA1 gene have an increased risk of developing breast cancer.

It is possible for a woman to have a test for the BRCA1 gene.

What reason might best persuade a woman to have the test?

- A If she did have the gene she could choose to have more regular tests for breast cancer.
- B If she did have the gene she would know that she would definitely get breast cancer.
- C She could inform her health insurance company if she had the gene.
- D She would then know if she had passed the gene on to her daughters.

4 Duncan and David are twins. In their baby photographs it is impossible to tell them apart.

Their sister says that they are clones.

She is correct, but what does she mean?

- A They both inherited all of their genes from their father.
- B They developed from different eggs and sperm, which had the same combination of genes in them.
- C They have exactly the same alleles because they developed from the same fertilised egg.
- D They have slightly different combinations of alleles, but they are growing up in the same environment.

- 5 Now that they are adults, David's friends can easily identify him as different from his twin brother, Duncan.

What is the best explanation for this?

- A Their appearance depends on both the environment and their alleles.
- B As they grew up, their alleles developed and changed.
- C David's cells have different alleles to the ones in Duncan's cells.
- D Their environment completely controlled their appearance as they grew up.

The following information should be used to answer questions 6 and 7.

A scientist took some readings of the amount of carbon particles in the air near a power station.

She repeated the same test five times. She did her tests at 12 noon each day.

The table shows her results.

day	amount of carbon particles in $\mu\text{g}/\text{m}^3$					
	test 1	test 2	test 3	test 4	test 5	mean
Monday	60	59	58	51	62	60
Tuesday	77	73	75	76	74	75

- 6 What evidence is there that the tests are reliable?
- A On each day all five test results are similar to each other.
 - B The scientist calculated a mean of her results each day.
 - C The tests were all done at the same time of the day.
 - D The tests were repeated.

- 7 The mean values for Monday and Tuesday are different.

What is the most likely explanation of this difference?

- A The amount of carbon particles varies at different times in the day.
- B The mean can indicate the true value for the amount of carbon particles.
- C The power station burned more fuel on Tuesday.
- D There are outliers in the results.

- 8 A leaflet gives ideas about what people can do to reduce their impact on the environment.

1. Turn off lights when you leave a room.
2. Use low sulfur petrol.
3. Make sure your car has a catalytic converter.
4. Travel to work by bus instead of using the car.

Which ideas will reduce the amount of carbon dioxide we produce?

- A 1 and 3 only
 B 1 and 4 only
 C 1, 3 and 4 only
 D 1, 2, 3 and 4
- 9 When methane, a hydrocarbon, burns it reacts with oxygen from the air.

The diagram shows methane and oxygen molecules before the reaction.

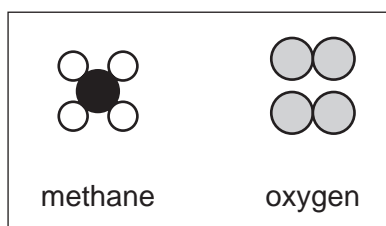

Which diagram shows the molecules after the reaction?

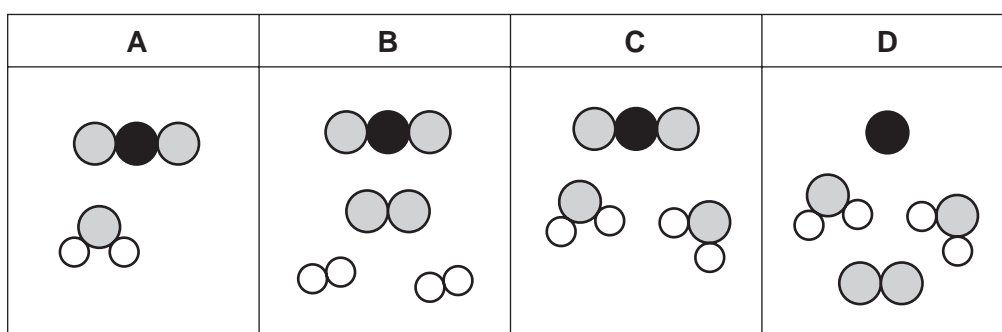

- 10 The diagram shows the arrangement of atoms in some molecules.



Which molecule is **not** shown in the diagram?

- A CO B CO₂ C H₂O D SO₂

11 Which statement about the theory of continental drift describes an explanation rather than an observation that supports the idea?

- A Coastal rocks on the opposite sides of oceans contain similar fossils.
- B Some continents have a close geometrical fit.
- C The Earth's crust is made up of plates moving over the mantle.
- D There are chains of mountains under most oceans.

12 Astronomers' measurements of the distances to galaxies are uncertain.

What is the best explanation for this?

- A The further away a galaxy is, the slower it is moving away from us.
- B The observations needed are very difficult to make.
- C The Universe started with a 'big bang'.
- D We do not know the mass of the Universe.

13 Scientists have found moons in distant solar systems.

Which statement about moons is true?

- A A moon is an object moving in orbit around asteroids.
- B A moon is an object moving in orbit around a planet.
- C A moon is an object moving in orbit around a star.
- D A moon is an object moving in orbit around the Sun.

14 A scientist studies two similar stars that are at different distances from Earth.

She measures the parallax angle and brightness of each star.

How does the parallax angle and brightness of the nearer star compare to the more distant star?

	parallax angle	brightness
A	larger	brighter
B	larger	dimmer
C	smaller	brighter
D	smaller	dimmer

15 How fast does light travel in space?

- A 300 000 000 km/s
- B 300 000 km/s
- C 300 000 m/s
- D 30 000 m/s

16 Fatty deposits in blood vessels supplying the heart muscle can cause a heart attack.

Which statement explains why?

- A The fat increases the blood flow to the heart muscle.
- B The fat kills heart muscle cells.
- C The fat reduces the amount of oxygen reaching the heart muscle.
- D The fat stops blood from leaving the heart muscle.

17 Vaccination protects us from disease-causing organisms.

Which statement explains why?

- A Vaccines are injected straight into the blood stream.
- B Vaccines contain safe forms of the disease-causing microorganism.
- C Vaccines cause the production of antibodies before the disease-causing microorganism enters the body.
- D Vaccines stop microorganisms entering the body.

18 The diagram represents the development of an antibiotic resistant strain of a type of bacterium.

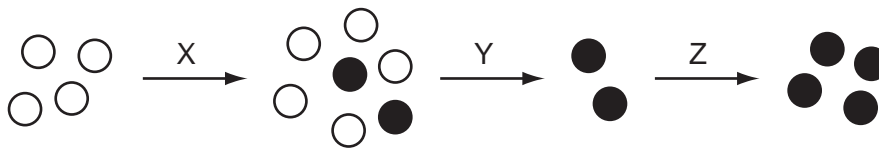

Which statement about this diagram is **not** correct?

- A In step X, mutations in the genes of the bacteria occur.
- B In step Y the resistant bacteria die.
- C The black circles represent the antibiotic resistant bacteria.
- D In step Z, antibiotic resistance is passed on to offspring.

19 Jane has a cold. It is the second time this year that she has been ill with a cold.

Which two statements best explain why Jane was able to catch a cold for the second time?

- 1 There is no effective vaccine against the cold virus.
- 2 There are many different types of cold virus.
- 3 Antibiotics do not work against viruses.
- 4 Different types of virus need different antibodies to destroy them.

A 1 and 2 **B** 1 and 4 **C** 2 and 3 **D** 2 and 4

20 Placebos are not used in some human drug trials.

Why is this?

- A** It is unfair to give an ill person a treatment that will not help them.
- B** They make it harder to work out the effect of the real drug.
- C** They make the trial last much longer.
- D** They may make the person more susceptible to disease.

21 Crude oil is a mixture of hydrocarbons.

Which statement about these hydrocarbon molecules is **not** correct?

- A** They are all the same length.
- B** They contain chains of atoms.
- C** They contain only carbon and hydrogen atoms.
- D** They produce carbon dioxide when they burn.

The following information should be used to answer questions **22** and **23**.

The table shows information about some polymers.

polymer	effect of heat	flexibility
melamine	does not melt	not flexible, hard and brittle
PVC	melts at about 300 °C	flexible
vulcanised rubber	does not melt	not very flexible, hard
nylon	melts at about 200 °C	flexible

22 Which polymer in the table has the weakest forces between molecules?

- A** melamine
- B** PVC
- C** vulcanised rubber
- D** nylon

23 Which polymers in the table contain cross links?

- A** all four polymers
- B** melamine and vulcanised rubber
- C** PVC and nylon
- D** melamine only

24 Synthetic rubber is made from crude oil.

The rubber can be used to make car tyres and surfaces for children's playgrounds.

Why is the Life Cycle Assessment different for rubber used in car tyres compared to rubber used in playground surfaces?

- A** Car tyres wear out more quickly than playground surfaces.
- B** More people drive cars than use playgrounds.
- C** The amount of rubber needed for a playground is more than for a car tyre.
- D** Synthetic rubber is non-biodegradable.

25 Which equation describes a reaction that does **not** produce carbon dioxide?

- A $\text{CH}_4 + 2\text{O}_2 \rightarrow \text{CO}_2 + 2\text{H}_2\text{O}$
- B $2\text{C}_3\text{H}_8 + 7\text{O}_2 \rightarrow 2\text{CO}_2 + 2\text{CO} + 2\text{C} + 8\text{H}_2\text{O}$
- C $6\text{CO}_2 + 6\text{H}_2\text{O} \rightarrow \text{C}_6\text{H}_{12}\text{O}_6 + 6\text{O}_2$
- D $\text{C}_6\text{H}_{12}\text{O}_6 + 6\text{O}_2 \rightarrow 6\text{CO}_2 + 6\text{H}_2\text{O}$

26 Some bricks are heated by the same non-ionising radiation but with different intensities and for different lengths of time.

Which combination of intensity and length of time has the greatest heating effect on the bricks?

	intensity	length of time
A	0.25	48 seconds
B	0.2	60 seconds
C	0.5	40 seconds
D	1	10 seconds

27 A radio wave signal gets weaker the further away it is from the transmitter.

Which statement correctly explains the decrease in intensity of the radio beam?

- A Photons cannot travel very far as they have relatively low energy.
- B Photons lose energy as they travel away from the transmitter.
- C Photons slow down as they travel away from the transmitter.
- D Photons spread out as they travel away from the transmitter.

28 What is the best description of the ALARA principle?

- A Accidents will happen whatever precautions you take.
- B Avoid all risk.
- C If you do not know what may happen, do not do it.
- D Reduce all hazards as much as possible.

29 The information in the table describes some differences in the features of two hominid species.

feature	<i>Homo erectus</i>	<i>Homo sapiens</i>
bones	large and heavy	slim and light
brain size	1000 cm ³	1300 cm ³
height	145 cm	170 cm
skull shape	large brow ridges	small brow ridges

Homo erectus is extinct. *Homo sapiens* is still alive.

The difference in which feature is most likely to be the reason for this?

- A bones
- B brain size
- C height
- D skull shape

30 This article appeared in a recent newspaper.

Trees are being killed by a 'sudden death' fungus.
 This fungus is thought to have been introduced into Britain in some trees that were shipped from Europe.
 It is spreading because of the recent warm wet summers.
 It results in many of the leaves on the trees turning brown and dying.

What are the main reasons for the death of the trees?

- A direct human activity and a change in the environmental conditions
- B direct human activity and a natural disaster
- C indirect human activity and a change in the environmental conditions
- D indirect human activity and a natural disaster

31 The first living things developed from non-living complex molecules.

Which statement about these molecules is **least** likely to be correct?

- A The molecules could copy themselves.
- B The molecules existed in many different varieties.
- C The molecules were produced by special conditions on Earth.
- D The molecules may have come from somewhere other than Earth.

32 In some parts of the world, farmers use 'slash and burn' techniques to create farmland.

The forest is cut down and left to dry out. Later, the dry wood is burned to ashes.

Why do the farmers burn the wood?

- A to increase the temperature of the soil
- B to provide nutrients for the soil
- C to put more carbon dioxide into the air for photosynthesis
- D to remove oxygen and water from the soil

33 After farmers have used 'slash and burn' the land is fertile for a short time but then after a few years crops do not grow well.

What is the best explanation for this?

- A Burning the trees has removed nutrients from the soil.
- B Nitrogen is taken from the soil when the crops are grown and harvested.
- C The soil only contains nutrients for growing trees, not crops.
- D Without the shade of the trees, the sun breaks down nutrients in the soil.

34 The diagram shows the label on a bottle of mayonnaise.

Ingredients: vegetable oil, egg, vinegar, sugar, salt, flavourings (mustard powder), preservative (potassium sorbate), stabilisers (guar gum), antioxidant (calcium disodium EDTA)
--

Which ingredient is used to stop the oil and vinegar in the mayonnaise separating?

- A calcium disodium EDTA
- B guar gum
- C potassium sorbate
- D salt

35 Antioxidants are added to mayonnaise.

Why are antioxidants added to mayonnaise?

- A to improve the appearance of the food
- B to improve the flavour of the food
- C to prevent oxygen reacting with the food
- D to prevent the growth of micro-organisms

36 The table shows information about the nuclei of four atoms.

	number of protons	number of neutrons
atom P	53	74
atom Q	54	73
atom R	53	78
atom S	52	73

Which pair of atoms are the same element?

- A P and Q
- B P and R
- C Q and R
- D Q and S

37 The following diagram shows the main parts of a coal fired power station.

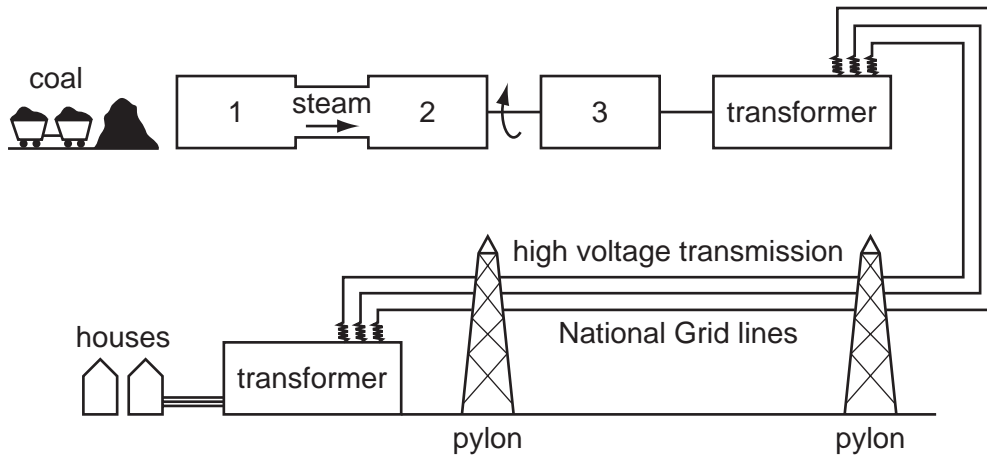

Which labels should be in positions 1, 2 and 3 on the diagram?

	position 1	position 2	position 3
A	furnace/boiler	generator	turbine
B	furnace/boiler	turbine	generator
C	generator	turbine	furnace/boiler
D	turbine	generator	furnace/boiler

- 38 A science teacher used the equipment shown to investigate the radiation emitted by a particular radioactive source.

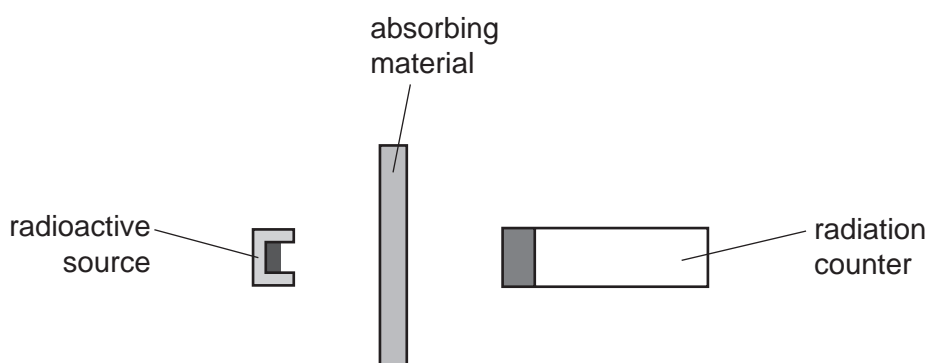

absorbing material	average number of counts in one minute
none	98
thin paper	27
1 mm aluminium	27
1 cm lead	8

What types of radiation were emitted by this source?

- A alpha particles and beta particles
 - B alpha particles and gamma rays
 - C beta particles and gamma rays
 - D beta particles only
- 39 Lee went to the hospital and had an injection of a radioactive material, technetium-99m.

Technetium-99m has a half-life of 6 hours.

What proportion of the technetium-99m will have decayed after 12 hours?

- A $\frac{1}{12}$
- B $\frac{1}{6}$
- C $\frac{3}{4}$
- D none

40 A student wrote a sentence about nuclear fission.

A1..... splits a large unstable nucleus into two smaller parts. These.....2..... in size and release more3..... .

Which words correctly complete gaps 1, 2 and 3 in the sentence?

	1	2	3
A	neutron	are roughly equal	neutrons
B	neutron	vary	neutrons
C	proton	are roughly equal	protons
D	proton	vary	protons

BLANK PAGE

Permission to reproduce items where third-party owned material protected by copyright is included has been sought and cleared where possible. Every reasonable effort has been made by the publisher (UCLES) to trace copyright holders, but if any items requiring clearance have unwittingly been included, the publisher will be pleased to make amends at the earliest possible opportunity.

University of Cambridge International Examinations is part of the Cambridge Assessment Group. Cambridge Assessment is the brand name of University of Cambridge Local Examinations Syndicate (UCLES), which is itself a department of the University of Cambridge.