

GREENLAWNS HIGH SCHOOL

PRELIMINARY EXAMINATION YEAR 2007-08

SUBJECT : TECHNICAL DRAWING APPLICATION
TIME : 3 HOURS

CLASS : X
MARKS : 100

THEEXAMPAPERS.COM

INSTRUCTIONS:

Solve any 3 questions from section A and 2 questions from section B.

Each section must be answered on a SEPARATE paper.

All construction lines must be shown.

Figures to the right indicate marks.

All dimensions are in mm.

Follow first angle method of Projection unless otherwise mentioned.

SECTION A (48 Marks)

Attempt any 3

Q.1

- a) On a map, the distance between two points is 14cm. The real distance between them is 20 km. Draw a diagonal scale of this map to read kilometres and hectametres and to measure upto 25km. Show a distance of 17.6km on this scale. (10)
- b) Construct a regular octagon of 40 mm side. Inscribe another octagon with its corners on the midpoints of the first octagon. (6)

Q.2. Refer figure [1]. Draw the oblique view using CABINET method. (16)
Use 45° as the receding angle. Mention length, width, height of the object.

Q.3.

- a) Draw an ellipse having Major axis = 160 mm and minor axis = 90 mm. use "CONCENTRIC CIRCLES" method. (8)
- b) Draw an auxiliary Top view of a cone of radius 25mm and axis 65 mm long with its axis inclined at 30° to HP and parallel to V.P. (8)

Q.4.

- a) Refer figure [2] copy the given Template. Insert all dimensions neatly. (10)
- b) An arc AB drawn with 50 mm radius subtends an angle of 45° at the centre. Determine the length of Arc AB and mention it. (6)

Q.5.

- a) Draw a series of four circles, each touching the preceding circle and two converging lines which makes an angle of 25° between them. Take the radius of the smallest circle as 10 mm. measure the radii of each circle and mention it. (10)
- b) Construct a square ABCD whose area is equal to the area of the kite PQRS such that diagonal QS = 40 and PS = PQ = 80 and QR = RS = 40 (6)
Measure the side of the square.

SECTION B (52 Marks)

Attempt any two questions

Q.6. REFER Figure [3]. Copy the given isometric view. Insert 10 dimensions. (26)
Show all construction work neatly.

Q.7.

a) Refer figure [4]. It shows the F.V and T.V of a Hexagonal Pyramid (14)
of side 30 mm and axis height 75mm. it is cut by a section plane inclined
at 45° to V.P. and 10mm away from the axis as shown. Draw

i) Sectional Front view

ii) Top View

iii) Auxilliary Front view showing True shape of the section.

iv) Development of the lateral surface

b) Refer figure [5]. It shows the F.V. and L.H.S.V of a cylinder of (12)
radii = 30mm, axis = 100mm in third angle. It is cut by a cutting plane
inclined at 30° to H.P as shown. Draw

i) Front View

ii) Sectional Top view

iii) Sectional left hand side view

iv) True shape of the section.

Q.8. Refer figure [6]. It shows the Front View and Top view of an object. Draw the
following views.

i) Sectional Front view along A-A

ii) Sectional Top view along B - B

iii) Left hand side view

iv) Insert 10 major dimensions. (26)

SECTION I

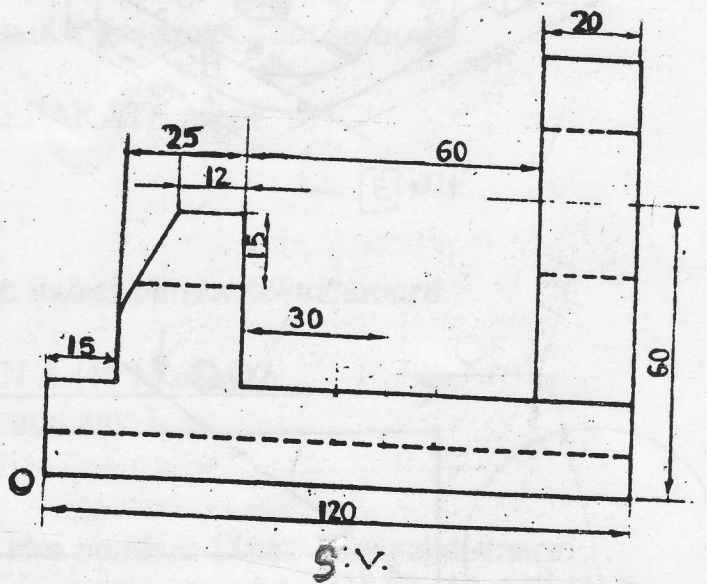
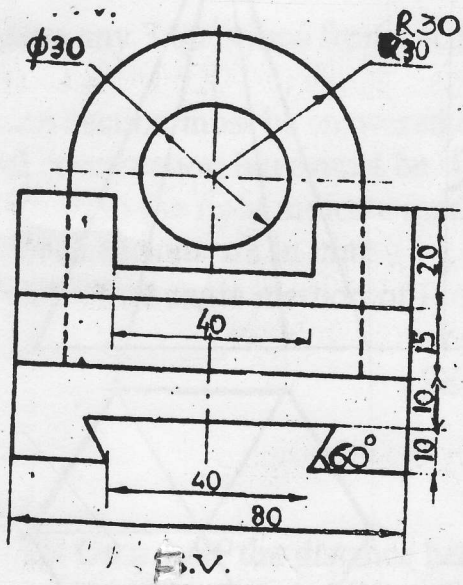

↑
FIG [1]

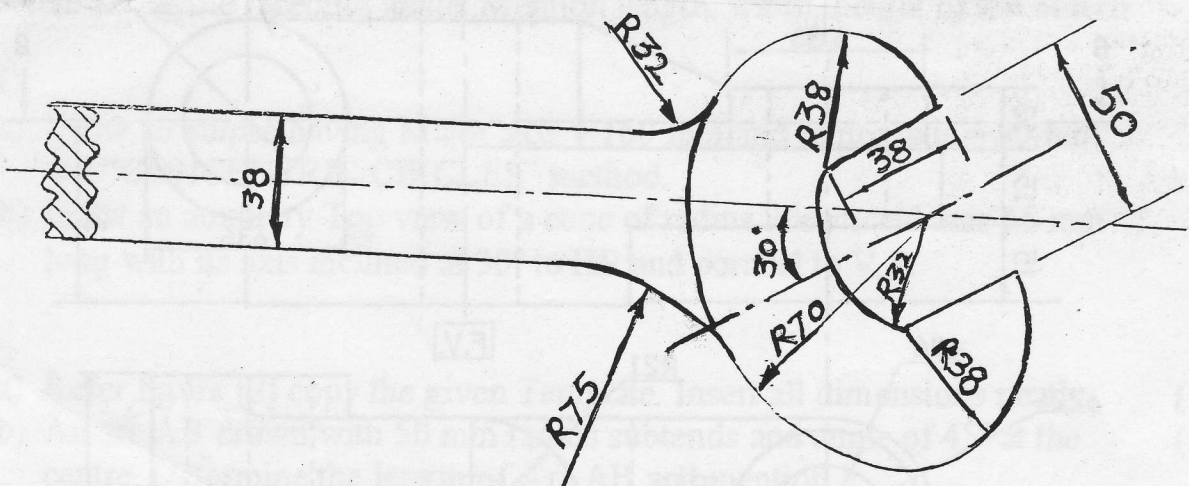

↑
FIG. [2]

SECTION B

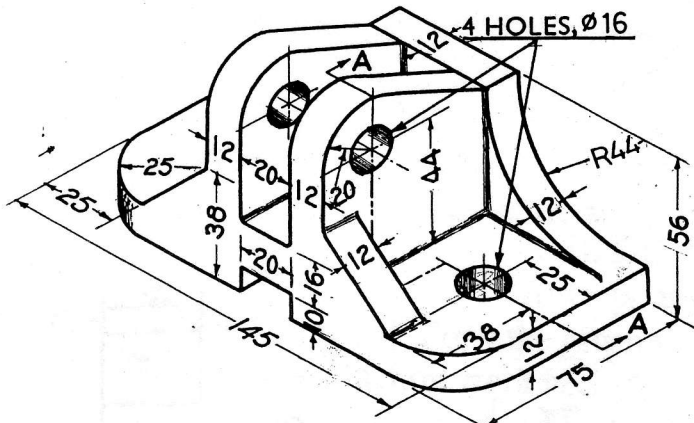
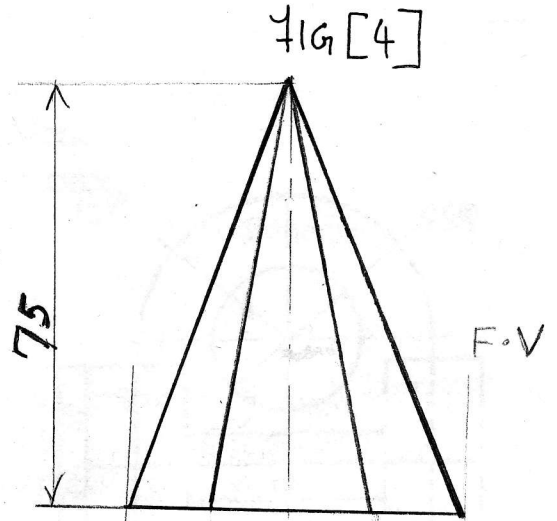
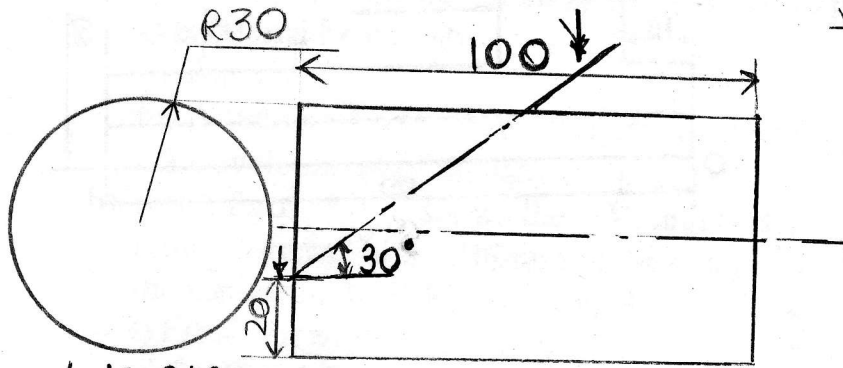

FIG [3]



F.V



L.H.S.V

F.V

FIG [5]

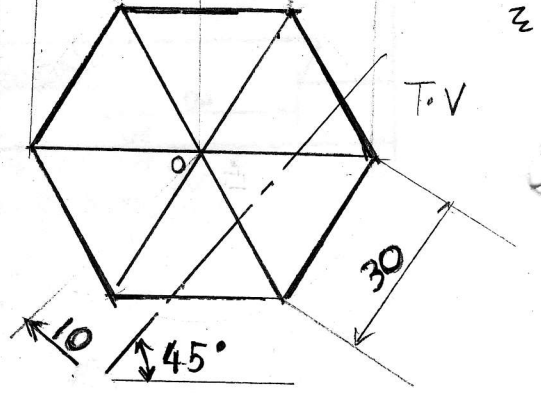

T.V

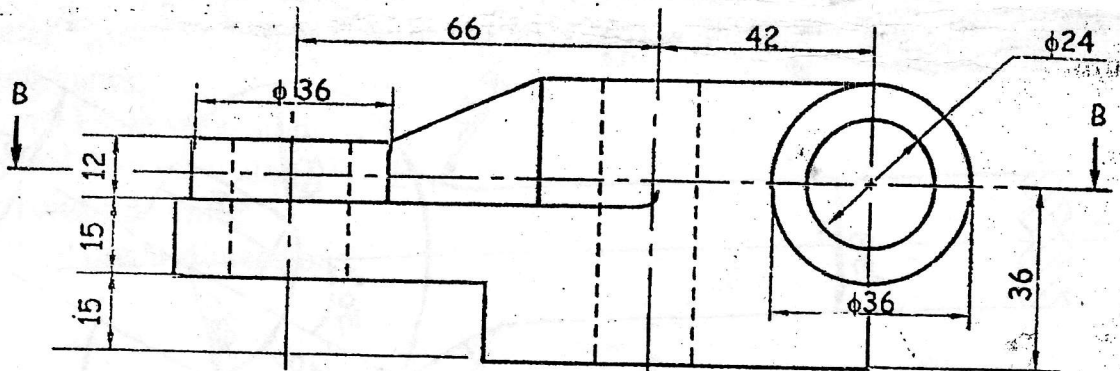

F.V

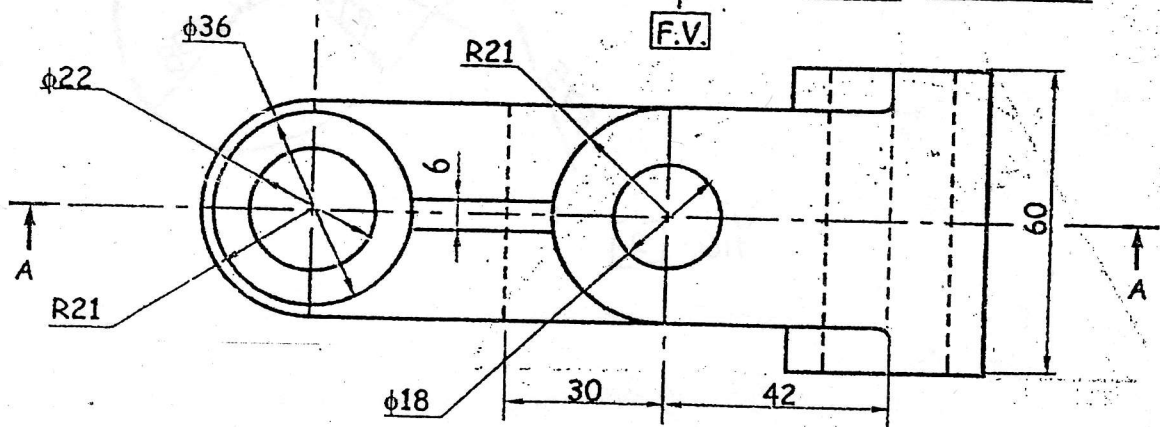

FIG [6]

T.V