



22146510



International Baccalaureate®
Baccalauréat International
Bachillerato Internacional

PHYSICS
STANDARD LEVEL
PAPER 1

Wednesday 7 May 2014 (morning)

45 minutes

INSTRUCTIONS TO CANDIDATES

- Do not open this examination paper until instructed to do so.
- Answer all the questions.
- For each question, choose the answer you consider to be the best and indicate your choice on the answer sheet provided.
- A clean copy of the **Physics Data Booklet** is required for this paper.
- The maximum mark for this examination paper is [30 marks].

1. The radius of a sphere is measured with an uncertainty of 2%. What is the uncertainty in the volume of the sphere?
- A. 2%
 - B. 4%
 - C. 6%
 - D. 8%

2. The force of air resistance F that acts on a car moving at speed v is given by $F = kv^2$ where k is a constant. What is the unit of k ?
- A. kg m^{-1}
 - B. $\text{kg m}^{-2} \text{ s}^2$
 - C. kg m^{-2}
 - D. $\text{kg m}^{-2} \text{ s}^{-2}$

3. A body moves on a straight line. The graphs show the variation of displacement with time. Which graph shows motion with negative acceleration?

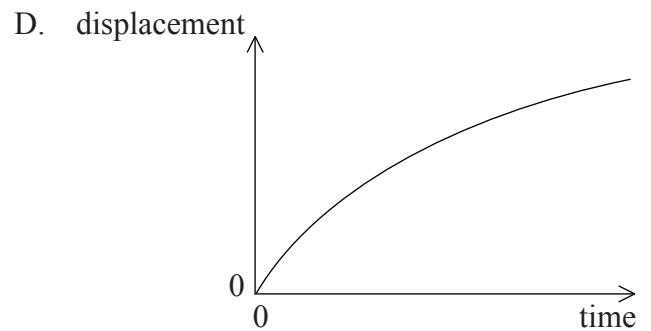
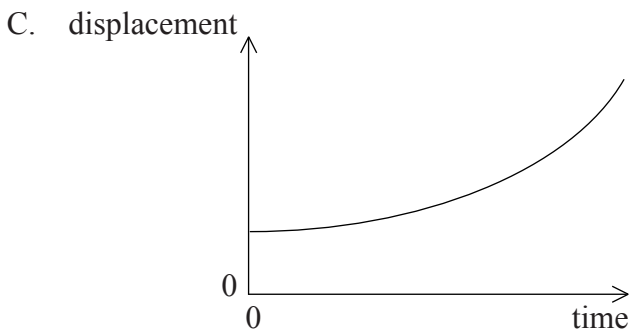
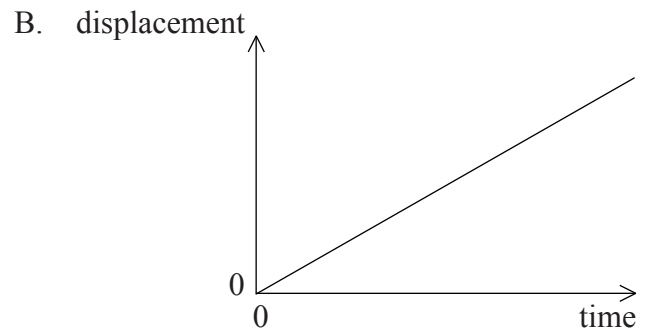
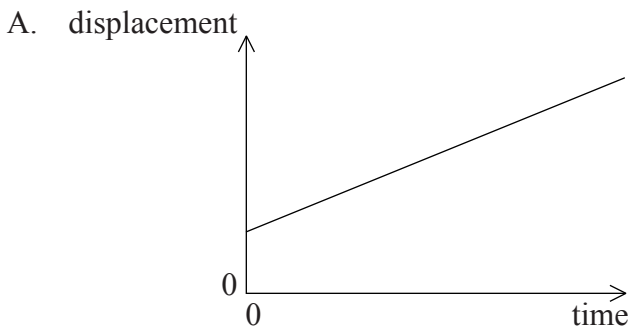

4. The graph shows how the net force F that acts on a body varies with the distance x that the body has travelled.

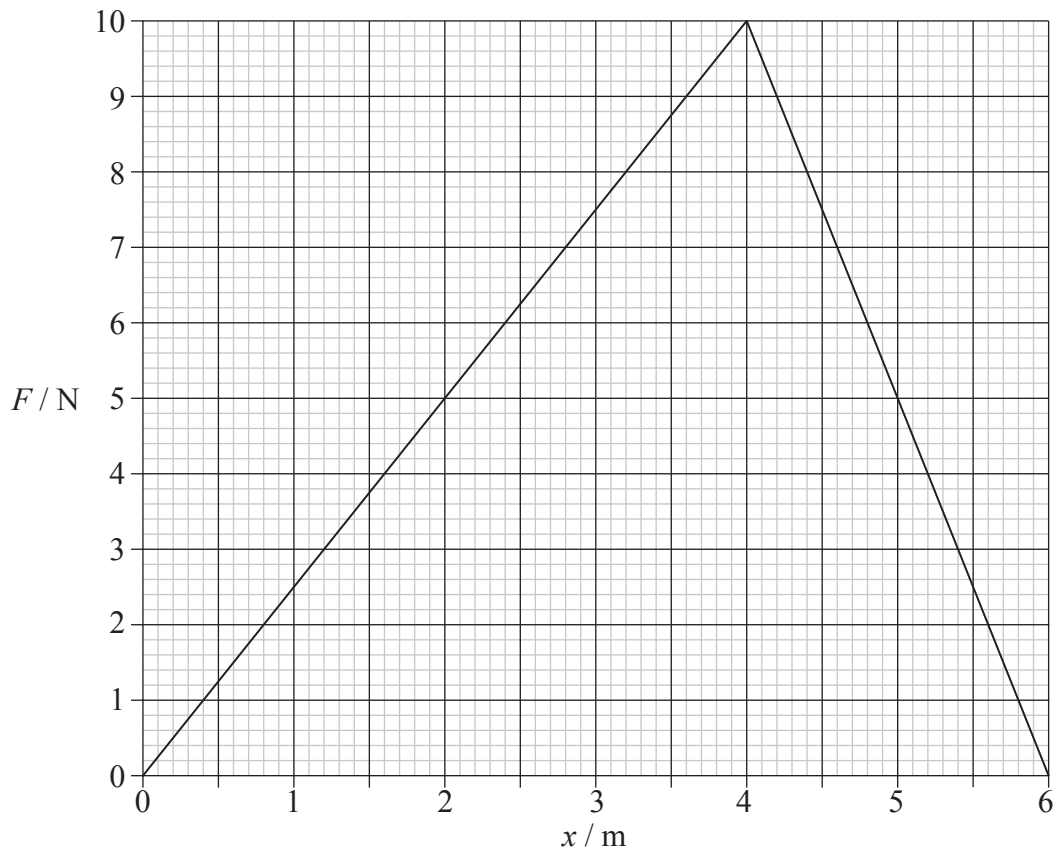

After travelling 6 m, the change in the kinetic energy of the body is

- A. 0J.
- B. 20J.
- C. 30J.
- D. 60J.

5. Two blocks of weight 5 N and 2 N are attached to two ropes, X and Y.

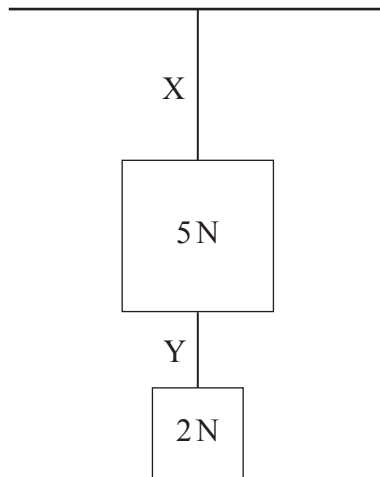

The blocks hang vertically. The mass of the ropes is negligible. What is the tension in X and the tension in Y?

	Tension in X	Tension in Y
A.	7 N	7 N
B.	7 N	2 N
C.	5 N	2 N
D.	5 N	3 N

6. A constant force of 12 N is applied for 3.0 s to a body initially at rest. The final velocity of the body is 6.0 m s^{-1} . What is the mass of the body?
- A. 1.5 kg
 - B. 6.0 kg
 - C. 24 kg
 - D. 36 kg

7. A cart of mass 4.0 kg is being pulled with a force of 24 N . The cart accelerates at 3.0 ms^{-2} . What is the net force on the cart?
- A. 6.0 N
B. 8.0 N
C. 12 N
D. 24 N
8. The maximum speed with which a car can take a circular turn of radius R is v . The maximum speed with which the same car, under the same conditions, can take a circular turn of radius $2R$ is
- A. $2v$
B. $v\sqrt{2}$
C. $4v$
D. $2v\sqrt{2}$
9. A mass M of an ideal gas X is kept in a container of volume V at kelvin temperature T . A second container has volume $2V$ and contains a mass $2M$ of an ideal gas Y at kelvin temperature $2T$.

What is the ratio $\frac{\text{average kinetic energy of molecules of gas Y}}{\text{average kinetic energy of molecules of gas X}}$?

- A. 1
B. 2
C. 4
D. 8

10. A fixed mass of water is heated by an electric heater of unknown power P . The following quantities are measured

- I. mass of water
- II. increase in water temperature
- III. time for which water is heated.

In order to calculate P , the specific heat capacity of the water is required. Which are also required?

- A. I and II only
 - B. I and III only
 - C. II and III only
 - D. I, II and III
11. A block of iron of mass 10 kg and temperature 10°C is brought into contact with a block of iron of mass 20 kg and temperature 70°C . No energy transfer takes place except between the two blocks. What will be the final temperature of both blocks?
- A. 30°C
 - B. 40°C
 - C. 50°C
 - D. 60°C

12. A wave of period 5.0 ms travels through a medium. The graph shows the variation with distance d of the displacement x of points in the medium.

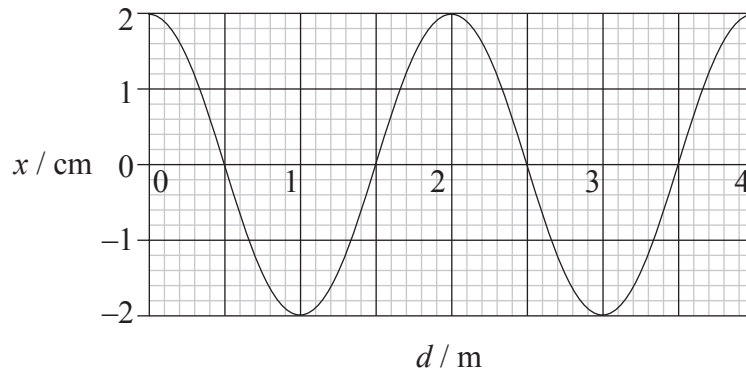

What is the average speed of a point in the medium during one full oscillation?

- A. 0 ms^{-1}
 - B. 4.0 ms^{-1}
 - C. 16 ms^{-1}
 - D. 400 ms^{-1}
13. A body undergoes simple harmonic motion. Which graph correctly shows the variation with displacement x of the velocity v of the body?

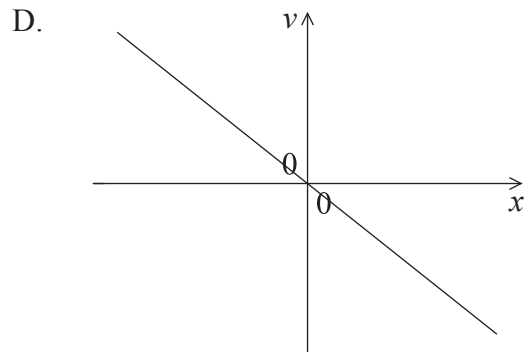
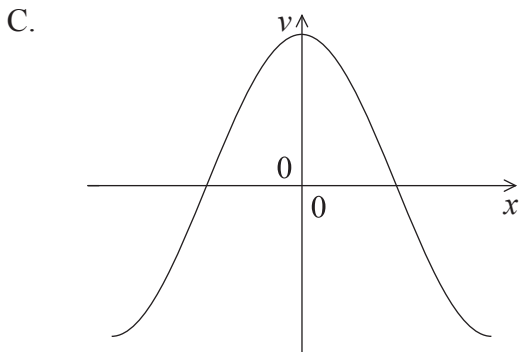
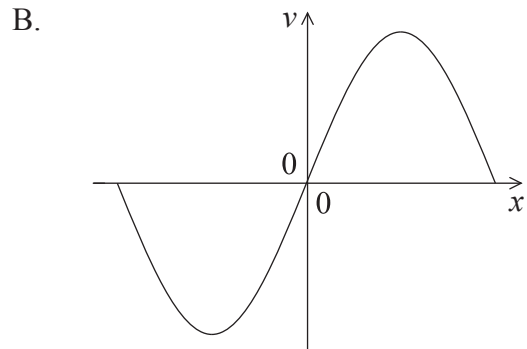
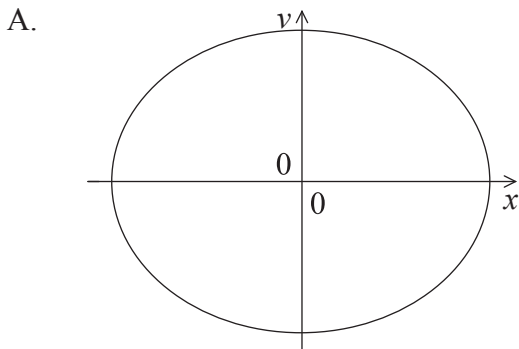

14. The speed of a wave in medium X is greater than the speed of the wave in medium Y. Which diagram shows the correct refraction of the wavefronts at the boundary between X and Y?

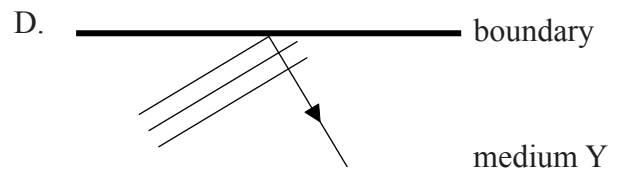
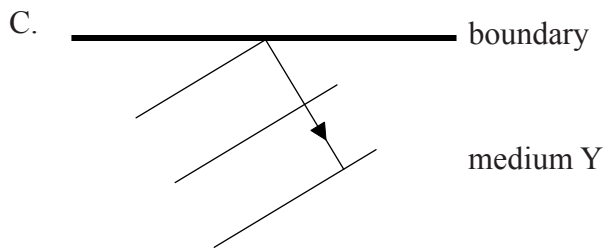
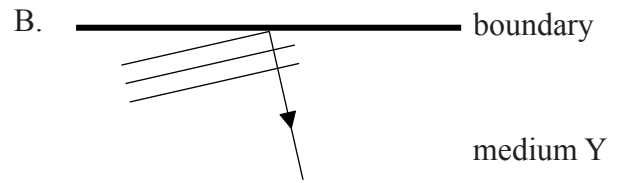
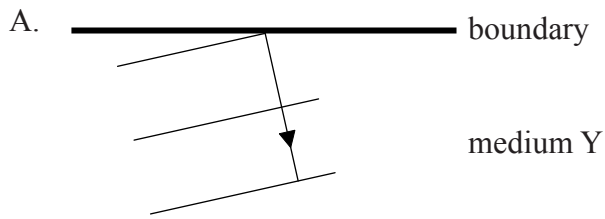
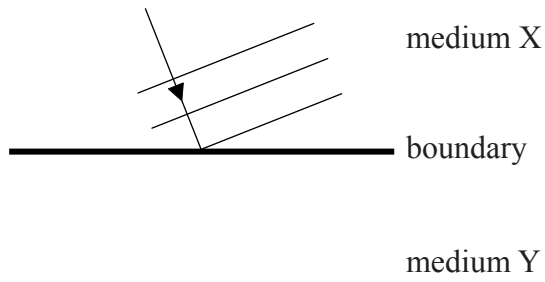

15. Two loudspeakers, L_1 and L_2 , emit identical sound waves.

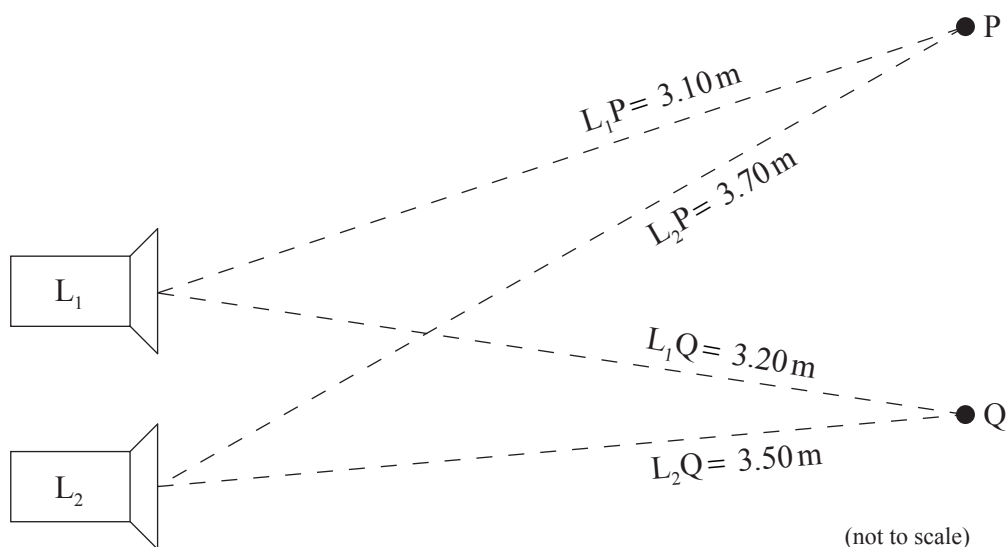

The waves leaving L_1 and L_2 are in phase and are observed at points P and Q.

The wavelength of the sound is 0.60 m. The distances of points P and Q from the loudspeakers are shown in the diagram.

Which of the following is true about the intensity of the sound at P and the intensity of the sound at Q?

	Intensity at P	Intensity at Q
A.	maximum	maximum
B.	maximum	minimum
C.	minimum	maximum
D.	minimum	minimum

16. Each of the resistors in the arrangements below has resistance R . Each arrangement is connected, in turn, to a power supply of constant emf and negligible internal resistance. In which arrangement is the current in the power supply greatest?

A.



B.

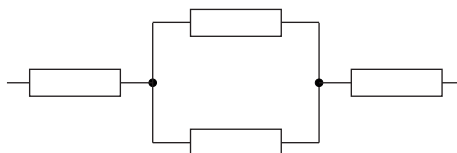

C.

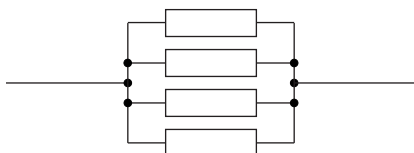

D.

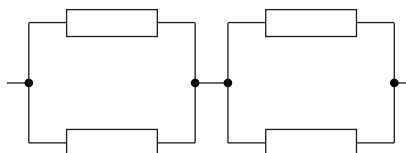

17. Two resistors of resistance 10Ω and 20Ω are connected in parallel to a cell of negligible internal resistance.

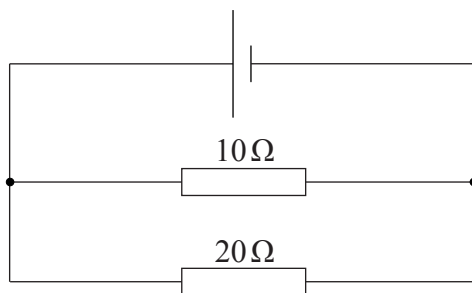

The energy dissipated in the 10Ω resistor in one second is Q . What is the energy dissipated in one second in the 20Ω resistor?

- A. $\frac{Q}{4}$
 - B. $\frac{Q}{2}$
 - C. $2Q$
 - D. $4Q$
18. A battery of emf 12V and negligible internal resistance is connected to a resistor of constant resistance 6Ω , an ideal ammeter and an ideal voltmeter.

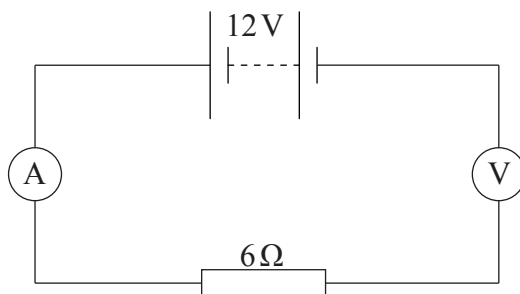

What is the reading on the ammeter and on the voltmeter?

	Ammeter reading / A	Voltmeter reading / V
A.	2.0	0
B.	2.0	12
C.	0	0
D.	0	12

19. A small point mass m is placed at the same distance from two identical fixed spherical masses far from any other masses.

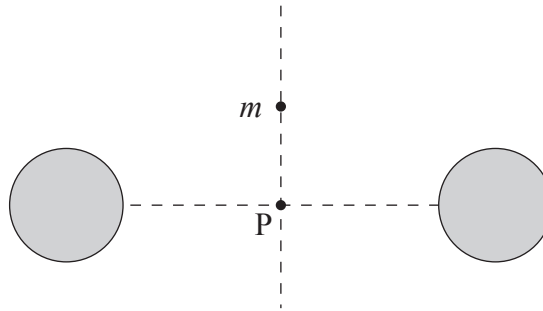

The point mass is released from rest. The point mass will

- A. move upwards.
 - B. stay where it is.
 - C. move towards P and stop there.
 - D. oscillate about point P.
20. Three parallel wires, X, Y and Z, carry equal currents. The currents in X and Z are directed into the page. The current in Y is directed out of the page.



Which arrow shows the direction of the magnetic force experienced by wire Z?

- A.
- B.
- C.
- D.

21. Point P is at the same distance from two charges of equal magnitude and opposite sign.

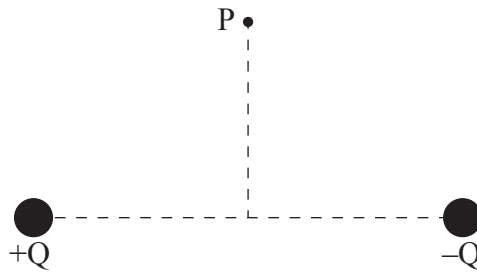

What is the direction of the electric field at point P?

A. 

B. 

C. 

D. 

22. The binding energy per nucleon of a ${}^3_1\text{H}$ nucleus is 3 MeV. What is the minimum energy needed to completely separate the nucleons of ${}^3_1\text{H}$?

A. 12 MeV

B. 9 MeV

C. 6 MeV

D. 3 MeV

23. The nuclear reaction ${}^2_1\text{H} + {}^3_1\text{H} \rightarrow {}^4_2\text{He} + {}^1_0\text{n}$ would best be described as
- A. alpha decay.
 - B. nuclear fission.
 - C. nuclear fusion.
 - D. neutron capture.
24. A radioactive sample has activity A_0 at $t = 0$. What will be the activity of the sample after two half-lives?
- A. zero
 - B. $\frac{A_0}{4}$
 - C. less than $\frac{A_0}{4}$ if the sample is kept at high pressure
 - D. greater than $\frac{A_0}{4}$ if the sample is kept at high temperature
25. A natural gas power station has an output of 600 MW and an efficiency of 50%. The mass of natural gas that is burned per second is 20 kg. What is the energy density of natural gas?
- A. 15 MJ kg^{-1}
 - B. 30 MJ kg^{-1}
 - C. 40 MJ kg^{-1}
 - D. 60 MJ kg^{-1}
26. A black body has kelvin temperature T and surface area A . The total power radiated by the body is P . What is the new power radiated when T is doubled and A is halved?
- A. $4P$
 - B. $8P$
 - C. $16P$
 - D. $32P$

27. Which of the following best defines non-renewable fuels?
- A. They produce a lot of degraded energy in comparison with renewable fuels
 - B. They have very high energy density but produce greenhouse gases
 - C. They cannot be produced again
 - D. Their rate of consumption is much greater than the rate at which they are being produced
28. The average intensity of the solar radiation incident on a planet is 200 W m^{-2} . The albedo of the planet is 0.6. The average temperature of the planet is constant.

Which of the following is a correct statement about the intensity of radiation reflected and radiated by the planet?

	Intensity reflected by planet	Intensity radiated by planet
A.	120 W m^{-2}	80 W m^{-2}
B.	120 W m^{-2}	less than 80 W m^{-2}
C.	80 W m^{-2}	120 W m^{-2}
D.	80 W m^{-2}	less than 120 W m^{-2}

29. A uranium nuclear fission reactor that attempts to operate without a moderator would
- A. suffer core meltdown.
 - B. not require uranium enrichment.
 - C. produce too much energy.
 - D. produce very little energy.
30. Which process **does not** contribute to an increase in mean sea-level?
- A. The melting of ice in icebergs floating in sea water
 - B. The melting of land-based ice in glaciers
 - C. The expansion of the volume of sea water due to heating
 - D. The melting of ice sheets in Greenland and Antarctica