



PHYSICS
HIGHER LEVEL
PAPER 1

Friday 10 November 2000 (afternoon)

1 hour

INSTRUCTIONS TO CANDIDATES

- Do not open this examination paper until instructed to do so.
- Answer all the questions.
- For each question, choose the answer you consider to be the best and indicate your choice on the answer sheet provided.

1. When an ideal gas in a thermally insulated chamber is compressed the volume V and pressure P are related by the equation

$$PV^\gamma = \text{constant}$$

where γ is a constant.

Which **one** of the following plots would produce a straight-line graph?

- A. P against $\frac{1}{V}$
- B. $\log P$ against $\log V$
- C. P against $\log V$
- D. $\log P$ against V
2. The power P dissipated in a resistor of resistance R in which there is a current I is given by

$$P = I^2 R$$

The uncertainty in the value of resistance of a particular resistor is $\pm 10\%$ and the uncertainty in the value of the current in the resistor is $\pm 3\%$. The best estimate for the uncertainty of the power dissipated is

- A. $\pm 6\%$.
- B. $\pm 9\%$.
- C. $\pm 16\%$.
- D. $\pm 19\%$.
3. When a car is moving at a speed v in a straight line the total force opposing its motion is F . The product Fv is a measure of the
- A. power developed by the car.
- B. rate of change of momentum of the car.
- C. work done by the car against the frictional forces.
- D. rate of change of kinetic energy of the car.

4. In the diagram a wooden block is resting on an inclined plane. The weight of the block is W and the normal reaction between the block and the plane is N and the frictional force acting on the block is F_f . Angle θ is the maximum angle of the plane before the block starts to slide down the plane. The coefficient of static friction between the block and the plane is μ .

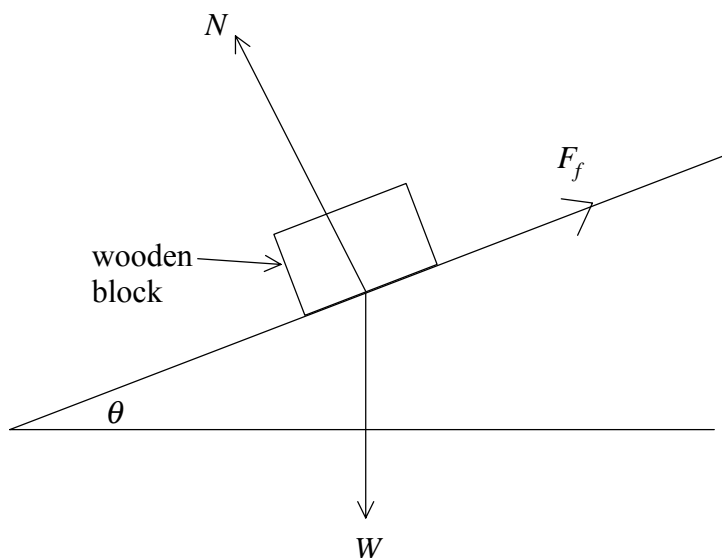

Which **one** of the following relationships between W and N is correct?

- A. $W = \mu N$
- B. $W \cos \theta = \mu N$
- C. $W \sin \theta = \mu N$
- D. $W \sin \theta = N$

5. The diagram shows a glider travelling on a friction-free linear air track.

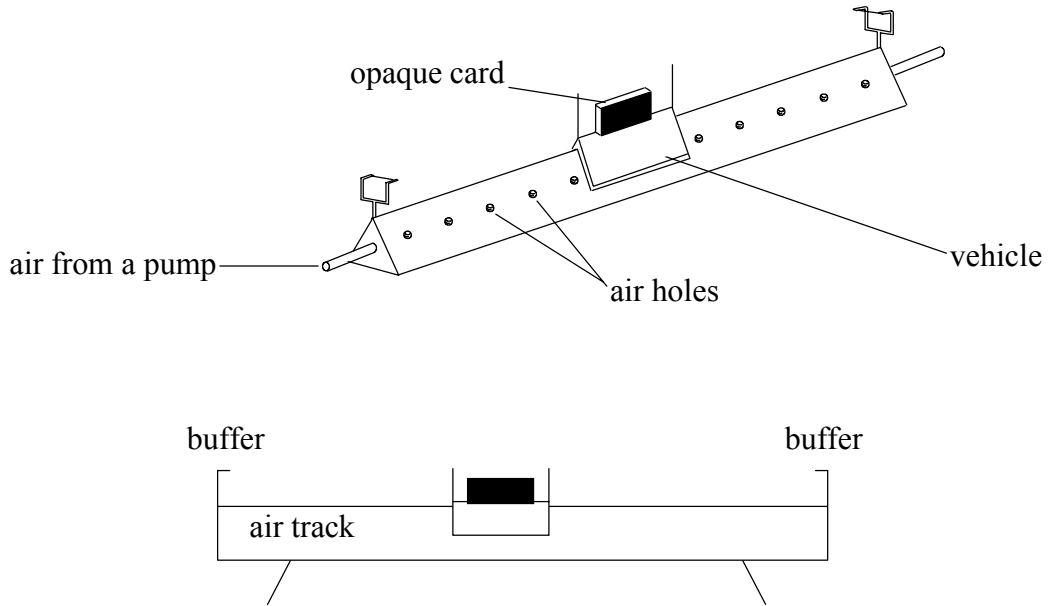

Which **one** of the following graphs best represents the variation of velocity with time as the glider bounces back and forth between the elastic buffers?

Graph A

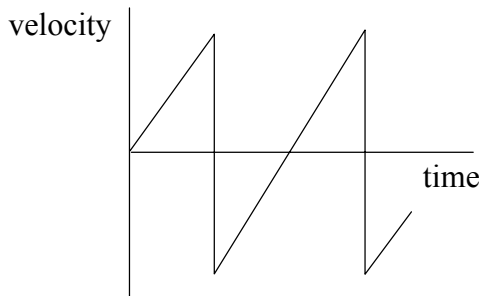

Graph B

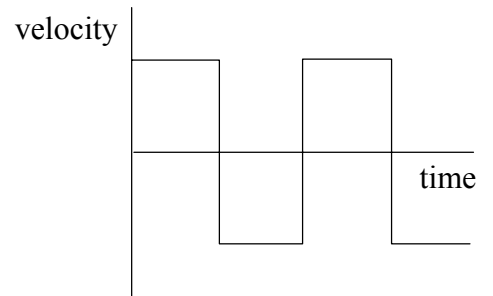

Graph C

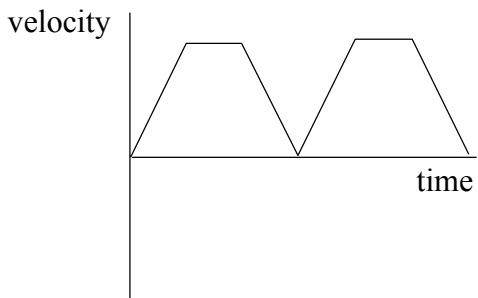

Graph D

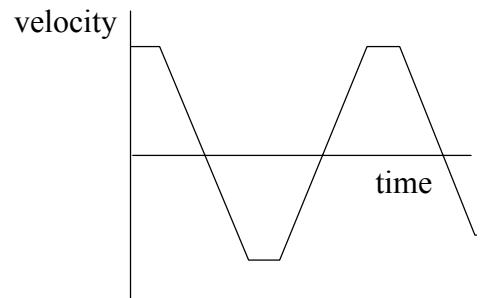

6. The diagrams show the direction and speed u of a ball before it strikes a vertical wall and its direction and speed v after striking the wall.

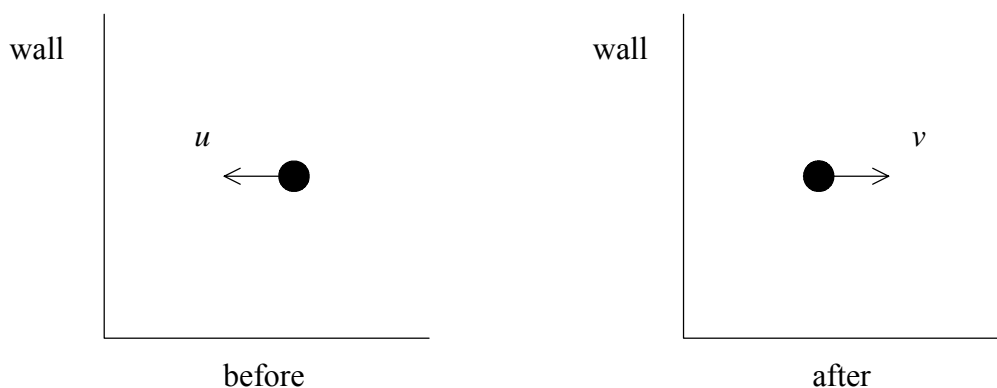

The ball is in contact with the wall for a time Δt .

The magnitude of the average force F exerted on the ball by the wall is given by

- A. $F = \frac{mu - mv}{\Delta t}$.
- B. $F = (mu - mv)\Delta t$.
- C. $F = \frac{mu + mv}{\Delta t}$.
- D. $F = (mu + mv)\Delta t$.
7. A particle of mass m moves with constant speed v in a circle of radius r . The work done on the particle by the centripetal force in one complete revolution is
- A. $2\pi m v^2$.
- B. $\frac{2\pi v^2}{m}$.
- C. $\frac{2\pi m}{v^2}$.
- D. zero.

8. A block of mass M is pushed along a horizontal, frictionless surface by a force of magnitude F . The force makes an angle θ with the horizontal.

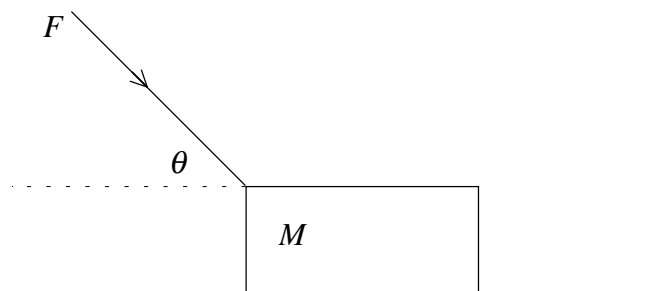

The magnitude of the acceleration of the block is

- A. zero.
- B. $\frac{F \cos \theta}{M}$.
- C. $\frac{F \sin \theta}{M}$.
- D. $\frac{F}{M}$.
9. The diagram shows two balls P and Q at the same height above the ground. Ball P is projected horizontally and at the same instant ball Q is allowed to fall vertically.

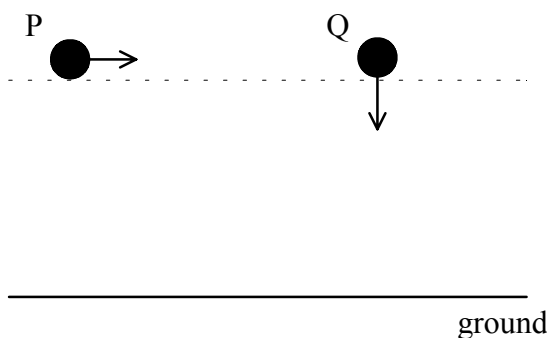

Which **one** of the following statements is **true**?

- A. Both balls hit the ground with the same velocity.
- B. Both balls take the same time to reach the ground.
- C. Both balls hit the ground with the same speed.
- D. The balls have different accelerations whilst falling.

10. A mass is suspended from a spring and set into vertical oscillation with a frequency f . Because of frictional forces the mass will eventually stop oscillating. At some time during the oscillations the amplitude of oscillation is equal to half its initial amplitude. At this point the frequency of oscillation is

A. $\frac{f}{2}$.

B. f .

C. $f\sqrt{2}$.

D. $2f$.

11. Two satellites P and Q of equal mass are in orbit about the Earth. Satellite P is further away from the Earth than Q.

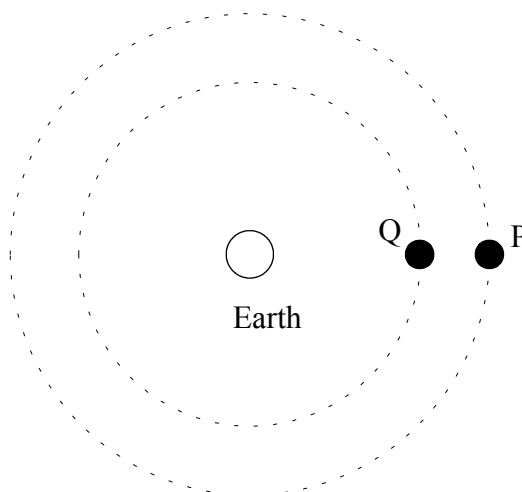

Which **one** of the following quantities will be **greater** for P than for Q?

A. The gravitational potential energy.

B. The speed.

C. The acceleration.

D. The gravitational force.

12. The diagram shows two planets X and Y.

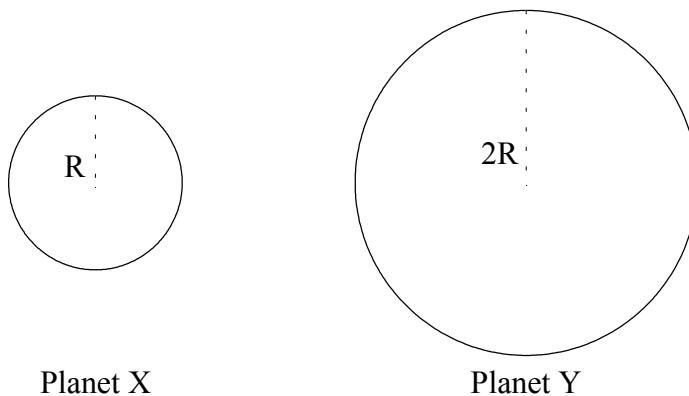

Planet X and planet Y have the same mean density.
The radius of planet X is half that of planet Y.

The ratio $\frac{\text{gravitational field at the surface of planet X}}{\text{gravitational field at the surface of planet Y}}$ is

- A. $2\sqrt{2}$.
- B. 2.
- C. $\sqrt{2}$.
- D. $\frac{1}{2}$.

13. In the diagrams the block of mass M is pushed along a frictionless, horizontal surface such that it compresses the spring S . The compression spring constant is k .

When the spring has been compressed by an amount e the block is held stationary and then the pushing force is removed from the block.

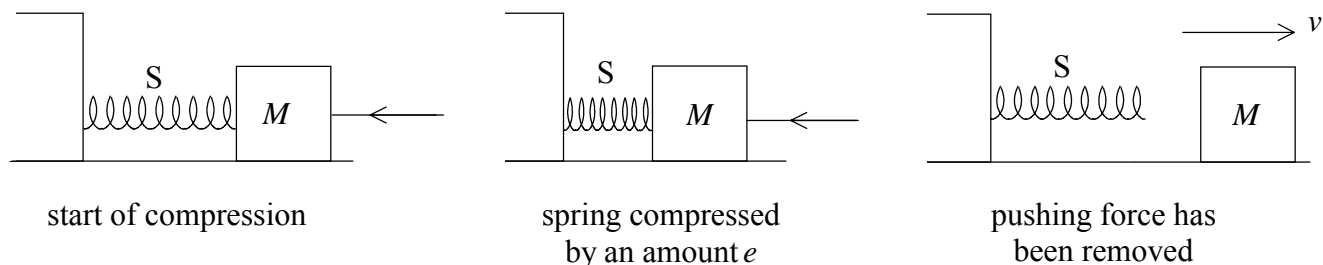

The speed v of the block when it is no longer in contact with the spring will be

- A. $e\sqrt{\frac{k}{M}}$.
- B. $e\sqrt{\frac{M}{k}}$.
- C. $\sqrt{\frac{ke}{M}}$.
- D. $\sqrt{\frac{M}{ke}}$.

14. Ball A travelling with speed V in the direction shown makes a glancing collision with another ball B of the same mass. After collision the balls move off with speeds V_A and V_B in the directions shown.

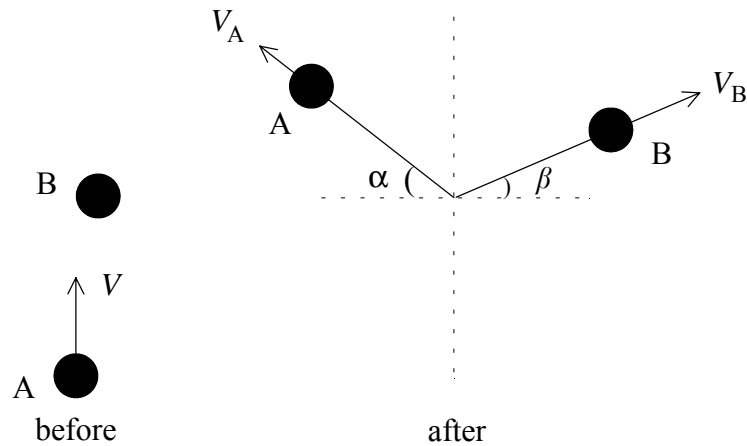

Which **one** of the following is true?

- A. $V_A \cos \alpha = V_B \cos \beta$
 - B. $V = V_A \cos \alpha + V_B \cos \beta$
 - C. $V_A \sin \alpha = V_B \sin \beta$
 - D. $V = V_A + V_B$
15. The diagram shows a section of double glazed window. The panes of glass are separated by an air gap that is of the same thickness as the two panes of glass. The room temperature is greater than the outside temperature and both temperatures are constant.

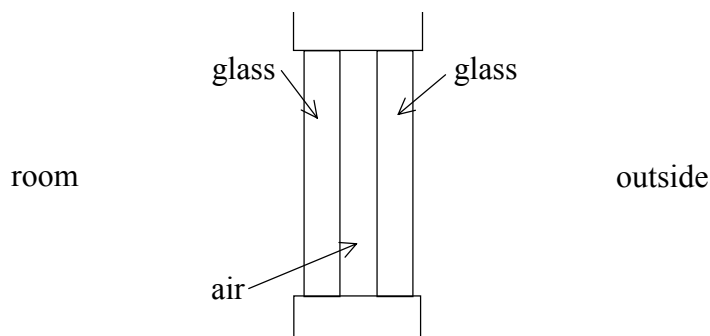

Which **one** of the following statements is **true**?

- A. There is no energy transfer from the room to the outside.
- B. The rate of energy transfer across the glass is the same as that across the air gap.
- C. The rate of energy transfer across the glass is greater than that across the air gap.
- D. The rate of energy transfer across the glass is less than that across the air gap.

16. The graph shows how the force between two molecules in a solid varies with their separation.

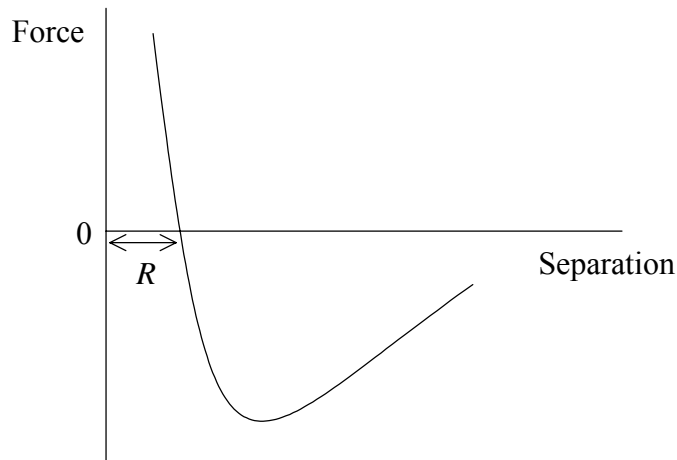

When the separation between the molecules is equal to R the **potential energy** of the molecules is

- A. a maximum.
 - B. a minimum.
 - C. zero.
 - D. infinite.
17. A rod is made from metal that has a coefficient of linear expansion of the order of $10^{-5} \text{ }^\circ\text{C}^{-1}$. If the temperature of the rod is raised by $1000 \text{ }^\circ\text{C}$ then it will increase in length by about
- A. 0.1%.
 - B. 1%.
 - C. 10%.
 - D. 100%.

18. In a given time interval 1200 J of energy is extracted from a refrigerator cabinet and 1800 J of energy is ejected to the outside. The coefficient of performance of the refrigerator is

- A. 0.5
- B. 0.7
- C. 2
- D. 4

19. When light waves travel from air to glass which **one** of the following happens to the frequency and wavelength of the light?

	Frequency	Wavelength
A.	stays the same	decreases
B.	decreases	increases
C.	stays the same	increases
D.	increases	decreases

20. The diagram shows two loudspeakers connected to the same signal generator. As a microphone is moved along the path XY a series of maximum and minimum sound levels is detected.

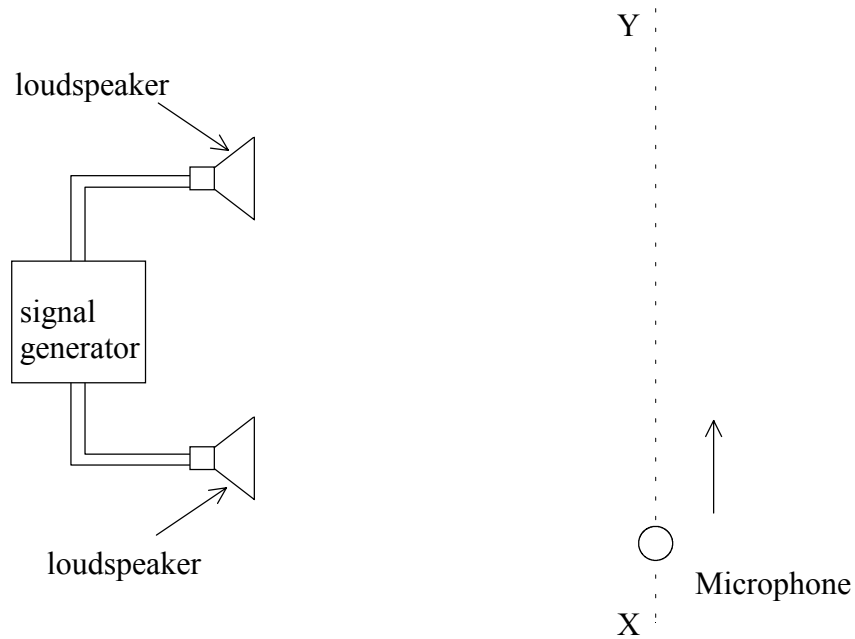

- Which **one** of the following actions on its own will **increase** the separation between the maximum and minimum sound levels?
- A. Moving the speakers closer to the line XY.
 - B. Increasing the separation between the speakers.
 - C. Increasing the amplitude of the sound waves.
 - D. Decreasing the frequency of the sound waves.
21. The frequency of the fundamental note produced by an organ pipe that is open at both ends is 300 Hz. The frequency of the next harmonic is
- A. 400 Hz.
 - B. 600 Hz.
 - C. 800 Hz.
 - D. 900 Hz.

22. Light can be transmitted along a curved optical fibre. Which **one** of the following phenomena can explain this?
- A. Dispersion
 - B. Diffraction
 - C. Total internal reflection
 - D. Interference

23. In the diagram a vibrator attached to a string under tension sets up a standing wave. The string vibrates in the mode shown.

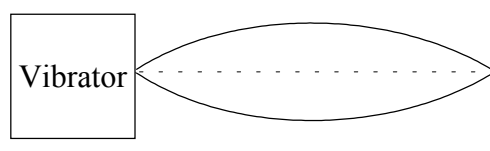

If the frequency of the vibrator is kept constant by what factor must the tension be changed in order that the next standing wave mode (harmonic) is produced?

- A. $\frac{1}{4}$
 - B. $\frac{1}{2}$
 - C. 2
 - D. 4
24. A sound source emits a note of constant frequency. An observer is travelling in a straight line towards the source at a constant speed. As she approaches the source she will hear a sound that
- A. gets higher and higher in frequency.
 - B. gets lower and lower in frequency.
 - C. is of constant frequency but of a frequency higher than that of the sound from the source.
 - D. is of constant frequency but of a frequency lower than that of the sound from the source.

25. Two resistors of equal resistance are connected in **series** to a battery with negligible internal resistance. The current drawn from the battery is 1.0 A.

When the two resistors are connected in **parallel** to the battery the current drawn will be

- A. 0.5 A.
 - B. 1.0 A.
 - C. 2.0 A.
 - D. 4.0 A.
26. In the diagram the voltmeter V has a resistance of $100\text{ k}\Omega$ and is connected such as to measure the potential difference across the $100\text{ k}\Omega$ resistor. The battery has an emf of 5.0 V and negligible internal resistance.

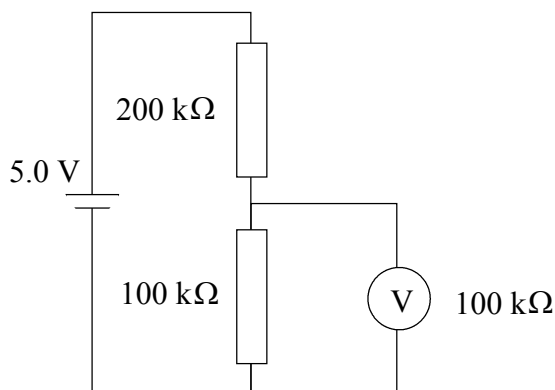

The reading on the voltmeter will be

- A. 4.0 V.
- B. 2.5 V.
- C. 1.0 V.
- D. zero.

27. Which **one** of the graphs best shows how the electrostatic potential due to a charged, hollow metal sphere of radius a varies with distance from the centre of the sphere?

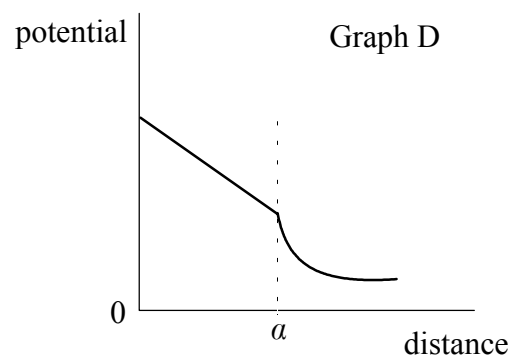
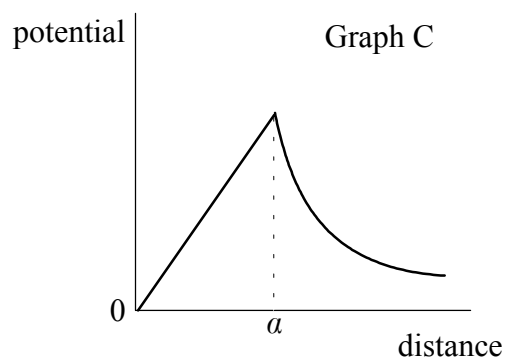
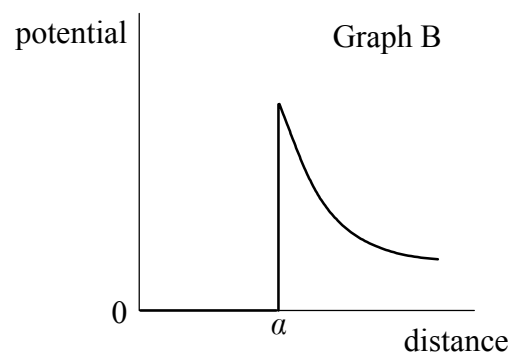
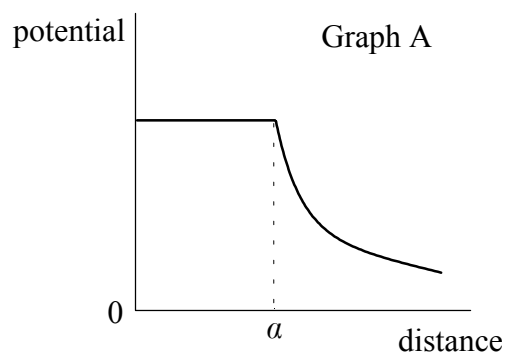

28. A loop made of conducting material is rotated about the vertical axis XY. At all times during the rotation the loop is in a region of uniform magnetic field

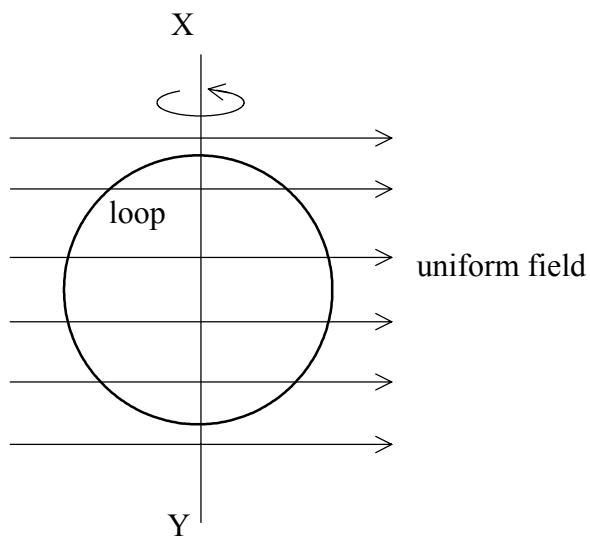

At a particular instant, in the position shown, the plane of the loop is parallel to the direction of the magnetic field. At this instant which **one** of the following about the induced current and the flux is **true**?

	induced current in the loop	flux linking the loop
A.	maximum	maximum
B.	maximum	zero
C.	zero	zero
D.	zero	maximum

29. In the diagram four long wires are placed at the corner of a square and carry equal currents. The direction of the current in wires P and R is into the plane of the paper and in wires Q and S is out of the plane of the paper.

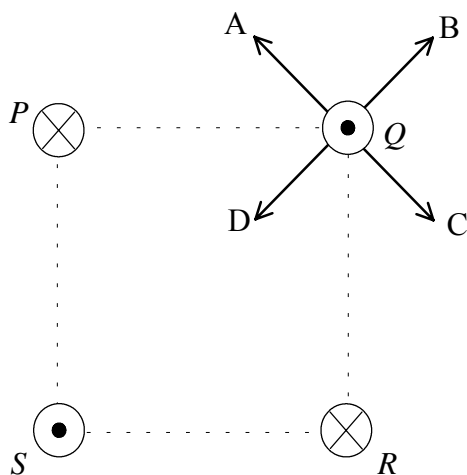

Which labelled arrow correctly shows the direction of the resultant force on wire Q?

- A. Arrow A
- B. Arrow B
- C. Arrow C
- D. Arrow D

30. The diagram shows a long solenoid of length L connected to a battery of negligible internal resistance. The magnetic field strength at the centre of the solenoid is T .

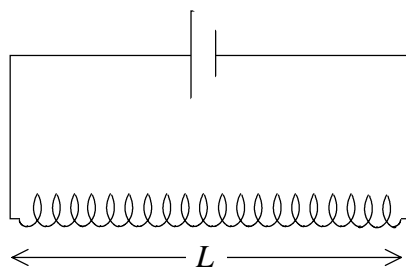

The solenoid is now disconnected from the battery and cut in half and one of the halves is reconnected to the battery as shown below.

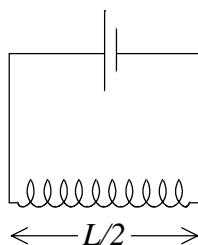

The best estimate of the field strength at the centre of this solenoid is

- A. $T/2$
 - B. T
 - C. $2T$
 - D. $4T$
31. The **primary** of an ideal transformer has 1000 turns and the **secondary** 100 turns. The current in the primary is 2 A and the input power to the primary is 12 W.

Which **one** of the following about the **secondary current** and the **secondary power output** is true?

	secondary current	secondary power output
A.	20 A	1.2 W
B.	0.2 A	12 W
C.	0.2 A	120 W
D.	20 A	12 W

32. A 60 W light bulb is designed to operate from a 240 V rms alternating current mains supply. The **maximum** value of the current drawn from the supply will be

- A. $\frac{1}{4}$ A.
- B. $\frac{1}{2}$ A.
- C. $\frac{\sqrt{2}}{4}$ A.
- D. $\frac{4}{\sqrt{2}}$ A.

33. Two metal parallel plates are connected to a battery as shown. The separation of the plates is d .

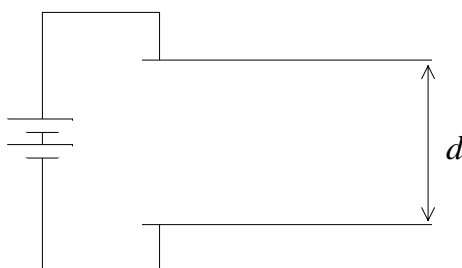

Which **one** of the graphs below best shows how the electric field strength E varies with the separation d of the plates?

Graph A

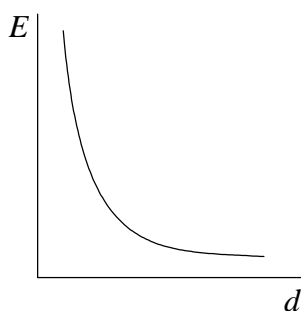

Graph B

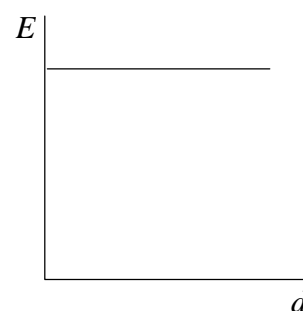

Graph C

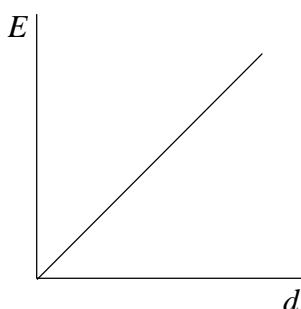

Graph D

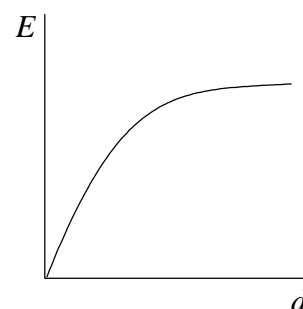

34. An alpha particle is fired at a thin piece of gold foil and as a result passes close to a gold nucleus. As it approaches the gold nucleus which **one** of the following is true about the potential energy and the magnitude of the momentum of the alpha particle?

	potential energy	momentum
A.	decreases	unchanged
B.	increases	decreases
C.	decreases	decreases
D.	increases	unchanged

35. The isotope Francium–224 has a half-life of 20 minutes. A sample of the isotope has an initial activity of 800 disintegrations s^{-1} . The approximate activity of the sample an hour later will be

- A. 270 disintegrations s^{-1} .
- B. 200 disintegrations s^{-1} .
- C. 100 disintegrations s^{-1} .
- D. zero.

36. A sample of a radioactive isotope X has the same initial activity as a sample of the isotope Y. The sample of X contains twice the number of atoms as the sample of Y. If the half-life of X is T then the half-life of Y is

- A. $2T$.
- B. $1.5T$.
- C. T .
- D. $0.5T$.

37. When light is shone onto a metal surface electrons can be ejected. Which **one** of the graphs best shows the relationship between the maximum kinetic energy E of the ejected electrons and the frequency f of the incident light?

Graph A

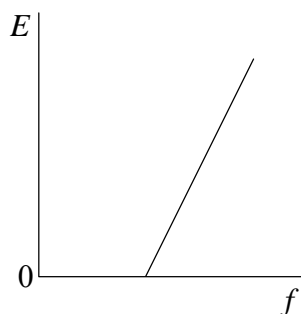

Graph B

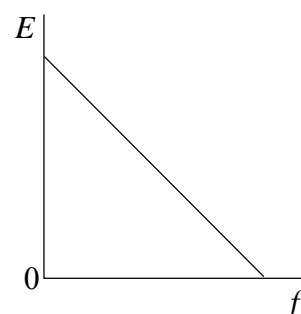

Graph C

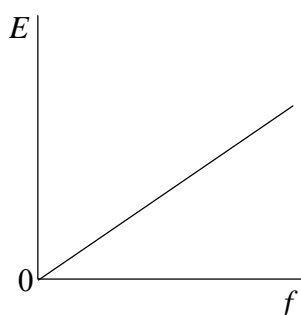

Graph D

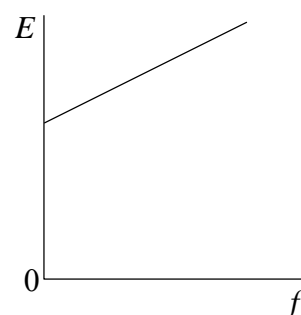

38. The diagram shows five energy levels of the hydrogen atom.

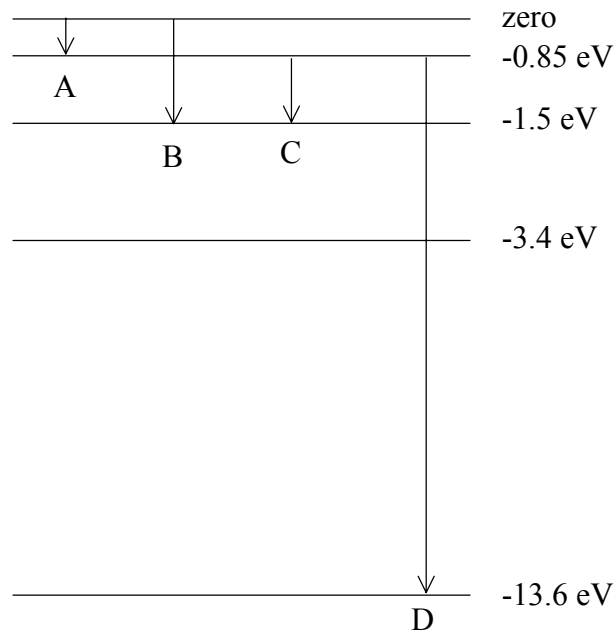

Which **one** of the electron transitions shown will give rise to a spectral line in the ultraviolet part of the electromagnetic spectrum?

- A. Transition A
 - B. Transition B
 - C. Transition C
 - D. Transition D
39. The de Broglie wavelength of an electron after acceleration through a potential difference V is proportional to
- A. V^2 .
 - B. V .
 - C. $\frac{1}{\sqrt{V}}$.
 - D. $1/V$.

40. Nuclear binding energy is a measure of the
- A. energy liberated in the radioactive decay of a nucleus.
 - B. total rest mass-energy of a nucleus.
 - C. energy released when a nucleus undergoes fission.
 - D. energy required to separate a nucleus into individual nucleons.
-