

Design technology
Standard level
Paper 3

Friday 15 May 2015 (morning)

Candidate session number

1 hour

--	--	--	--	--	--	--	--	--	--

Instructions to candidates

- Write your session number in the boxes above.
- Do not open this examination paper until instructed to do so.
- Answer all of the questions from one of the options.
- Write your answers in the boxes provided.
- A calculator is required for this paper.
- The maximum mark for this examination paper is **[30 marks]**.

Option	Questions
Option A — Food science and technology	1 – 6
Option B — Electronic product design	7 – 12
Option C — CAD/CAM	13 – 18
Option D — Textiles	19 – 24
Option E — Human factors design	25 – 30



Option A — Food science and technology

1. **Figures A1** and **A2** show two similar but different symbols used to indicate that a food is gluten free. Both use a head of wheat.

Figure A1: Gluten-free symbol



[Source: NFCA. Used with permission]

Figure A2: Crossed Grain symbol



[Source: www.coeliac.org.uk. Used with permission]

- (a) State **one** reason for the selection of a head of wheat for the gluten-free symbols shown in **Figures A1** and **A2**. [1]

.....
.....

- (b) Outline **one** way in which gluten intolerance impacts on diet. [2]

.....
.....
.....
.....

(Option A continues on the following page)



(Option A, question 1 continued)

- (c) Explain why many food retailers have produced ranges of gluten-free foods. [3]

.....
.....
.....
.....
.....
.....
.....
.....
.....
.....

2. (a) Define *lifestyle*. [1]

.....
.....

- (b) Outline **one** way in which lifestyle factors affect food choice and impact on health. [2]

.....
.....
.....
.....

(Option A continues on the following page)



(Option A continued)

- 3. **Figure A3** shows the Coca-Cola logo[®], which is an important part of the branding for Coca-Cola[®].

Figure A3: The Coca-Cola logo[®]

Removed for copyright reasons
Please go to: http://www.popandroll.com/coke-art/Coca-Cola-Art_Enjoy_Logo_Ribbon.jpg

- (a) Describe **one** way in which the packaging of Coca-Cola[®] has contributed to the development of the Coca-Cola[®] brand. [2]

.....
.....
.....
.....

- (b) Outline **one** purpose of food labelling. [2]

.....
.....
.....
.....

(Option A continues on the following page)



(Option A continued)

4. Describe the role of primary processing in the production of orange juice. [2]

.....
.....
.....
.....

5. Explain **two** principal causes of chemical spoilage of food. [6]

.....
.....
.....
.....
.....
.....
.....
.....
.....
.....
.....
.....
.....
.....
.....
.....
.....
.....
.....
.....
.....

(Option A continues on the following page)



Please **do not** write on this page.

Answers written on this page
will not be marked.



32EP07

Turn over

Option B — Electronic product design

7. **Figure B1** shows a circuit for an alarm to indicate if a freezer malfunctions.

Figure B1: An alarm circuit for a freezer

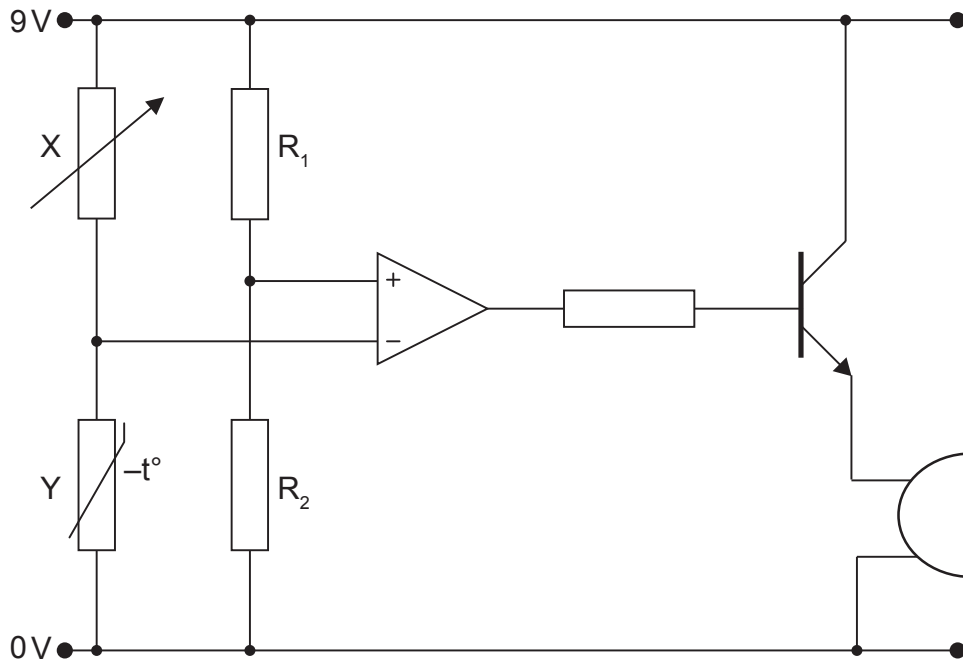

(a) State the function of the component labelled Y in the circuit shown in **Figure B1**. [1]

.....
.....

(b) Outline the function of the arrangement of components X, Y, R₁ and R₂. [2]

.....
.....
.....
.....

(Option B continues on the following page)



(Option B, question 7 continued)

(c) Explain how the circuit works so that the buzzer sounds if the freezer malfunctions. [3]

.....

.....

.....

.....

.....

.....

.....

.....

.....

8. Figure B2 shows a closed loop control system.

Figure B2: A closed loop control system

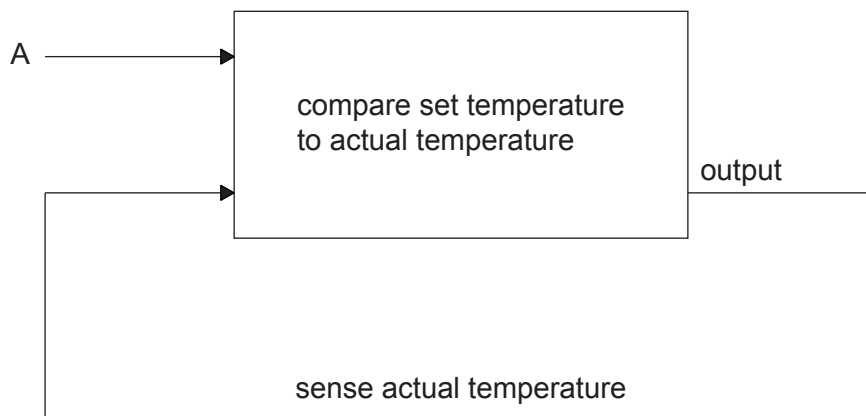

(a) State input A. [1]

.....

.....

(Option B continues on the following page)



Turn over

(Option B, question 8 continued)

(b) Describe how feedback is used in a closed loop control system.

[2]

.....

.....

.....

.....

(Option B continues on the following page)



(Option B continued)

9. Figure B2 shows a multiplexing system.

Figure B2: A multiplexing system

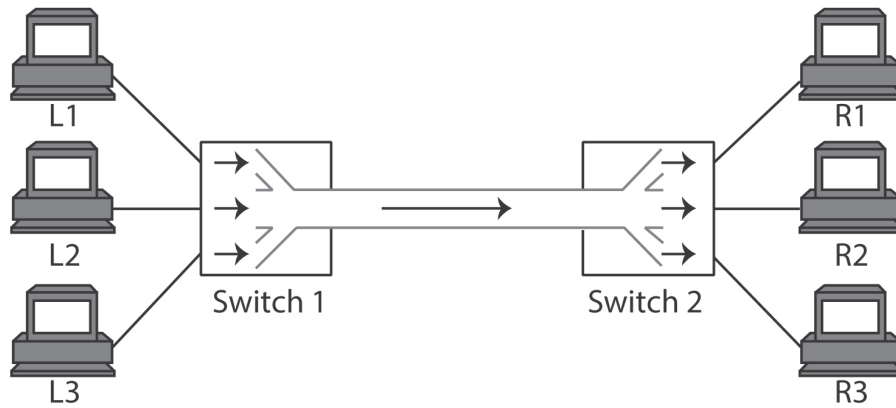

[Source: © International Baccalaureate Organization 2015]

(a) Describe an optical fibre. [2]

.....
.....
.....
.....

(b) Describe the role of synchronization in time division multiplexing. [2]

.....
.....
.....
.....

(Option B continues on the following page)



32EP11

Turn over

(Option B continued)

10. Describe Ohm's law.

[2]

.....
.....
.....
.....

11. Explain **two** benefits for the consumer of a manufacturer adopting a generic standard to implement a particular function in an electrical product.

[6]

.....
.....
.....
.....
.....
.....
.....
.....
.....
.....
.....
.....
.....
.....
.....
.....
.....
.....
.....
.....

(Option B continues on the following page)



(Option B continued)

12. Discuss **three** strategies that can be used to minimize the environmental impact of electronic products on disposal.

[9]

A large rectangular box containing a series of horizontal dotted lines for writing the answer to question 12.

End of Option B



32EP13

Turn over

Option C — CAD/CAM

13. **Figure C1** shows the shape profile of three cutting tools used in a computer numerical control (CNC) lathe.

Figure C1: CNC lathe cutting tools

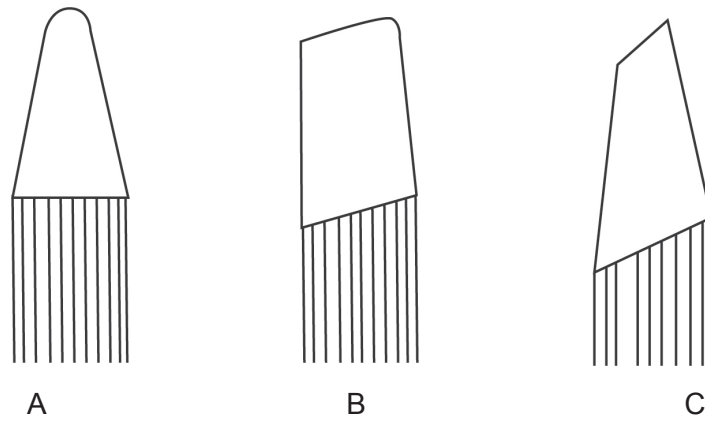

[Source: © International Baccalaureate Organization 2015]

(a) State the name of cutting tool A shown in **Figure C1**. [1]

.....
.....

(b) Outline why the feed rate of a CNC lathe would be changed according to the material being processed. [2]

.....
.....
.....
.....

(Option C continues on the following page)



(Option C, question 13 continued)

- (c) Compare the effects of using tools with large and small diameter cutting ends for CNC machining.

[3]

.....

.....

.....

.....

.....

.....

.....

.....

.....

.....

14. (a) Define *numerical control* (NC).

[1]

.....

.....

- (b) Outline **one** reason why some manufacturers prefer numerical control (NC) machines to computer numerical control (CNC) machines.

[2]

.....

.....

.....

.....

(Option C continues on the following page)



(Option C continued)

- 15. **Figure C2** shows a finite element analysis (FEA) CAD image of a crash (impact) test for a car.

Figure C2: FEA CAD image of a crash (impact) test for a car

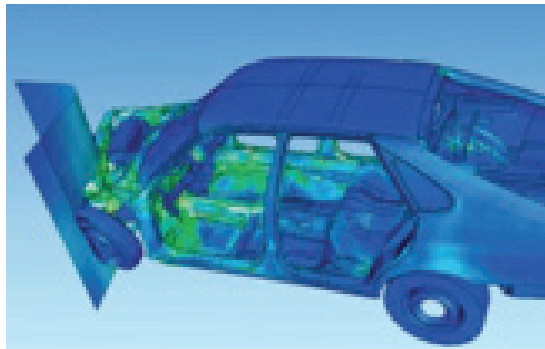

[Source: "FAE visualization". Licensed under Public Domain via Wikimedia Commons - https://commons.wikimedia.org/wiki/File:FAE_visualization.jpg#/media/File:FAE_visualization.jpg]

- (a) Describe the relationship of the dark and light colours in the FEA image shown in **Figure C2**. [2]

.....
.....
.....
.....

- (b) Outline **one** reason why the designer would carry out a series of tests to obtain reliable data from FEA CAD images similar to that in **Figure C2**. [2]

.....
.....
.....
.....

(Option C continues on the following page)



(Option C continued)

16. Outline why stereo lithography (SLA) is classified as a 3D printing process. [2]

.....

.....

.....

.....

17. Explain **two** ways in which the use of rapid prototyping influences the design development cycle for a new product. [6]

.....

.....

.....

.....

.....

.....

.....

.....

.....

.....

.....

.....

.....

.....

.....

.....

.....

.....

.....

.....

(Option C continues on the following page)



(Option C continued)

18. Discuss **three** reasons why car manufacturers often use animation to promote new vehicles on their websites.

[9]

A large rectangular box containing approximately 25 horizontal dotted lines for writing the answer.

End of Option C



Please **do not** write on this page.

Answers written on this page
will not be marked.



32EP19

Turn over

Option D — Textiles

19. **Figure D1** shows the Cedars men’s fleece jacket manufactured by the company Patagonia. The jacket is made from polyester fleece whereas the lining, shoulder panels and handwarmer pockets are made from 96 % nylon and 4 % Spandex (Lycra®).

Figure D1: Cedars men’s fleece jacket



[Source: www.moosejaw.com. Used with permission]

- (a) State **one** property of Spandex (Lycra®) which makes it suitable for use in the jacket shown in **Figure D1**.

[1]

.....

.....

(Option D continues on the following page)



32EP20

(Option D, question 19 continued)

- (b) Outline **one** material characteristic of polyester that makes it suitable for the jacket shown in **Figure D1**. [2]

.....
.....
.....
.....

- (c) Explain **one** disadvantage of nylon for the lining of the jacket shown in **Figure D1**. [3]

.....
.....
.....
.....
.....
.....
.....
.....
.....

(Option D continues on the following page)



32EP21

Turn over

(Option D continued)

20. Figure D2 shows a felt military hat (beret) being worn by a soldier.

Figure D2: Felt military hat (beret)



[Source: "COL Richard Clarke official portrait" by Unknown – Biographical Sketch, 75th Ranger Regiment. Licensed under Public Domain via Wikimedia Commons – http://commons.wikimedia.org/wiki/File:COL_Richard_Clarke_official_portrait.jpg#/media/File:COL_Richard_Clarke_official_portrait.jpg]

(a) State **one** characteristic of felt that has made it a popular fabric for military hats (berets).

[1]

.....

.....

(b) Outline why many felt military hats (berets) are made in one size only.

[2]

.....

.....

.....

.....

(Option D continues on the following page)



(Option D continued)

21. Figure D3 shows a textile vascular prosthesis.

Figure D3: Textile vascular prosthesis



[Source: H. Khelif, S. Ben Abdesslem, S. Dhouib and F. Sakli, 2011. Contribution to the Improvement of Textile Vascular Prostheses Crimping. *Trends in Applied Sciences Research*, **6**: 1019–1027. DOI: 10.3923/tasr.2011.1019.1027 URL: <http://scialert.net/abstract/?doi=tasr.2011.1019.1027>]

(a) Outline **one** reason why weaving is an appropriate technique to manufacture the prosthesis shown in **Figure D3**. [2]

.....

.....

.....

.....

(b) Outline **one** reason why the design of textile vascular prostheses requires a large and diverse design team. [2]

.....

.....

.....

.....

(Option D continues on the following page)



(Option D continued)

24. Discuss **three** reasons why the fashion industry for clothing developed rapidly in the 20th century.

[9]

A large rectangular box containing 25 horizontal dotted lines for writing the answer to question 24.

End of Option D



32EP25

Turn over

Option E — Human factors design

25. **Figure E1** shows a five-point comfort rating scale used to obtain data from a user trial for the prototype of a chair.

Figure E1: Five-point comfort rating scale

4	very comfortable
3	comfortable
2	average
1	slightly uncomfortable
0	very uncomfortable

(a) State the type of data scale represented by the comfort rating scale shown in **Figure E1**. [1]

.....
.....

(b) Outline why the user responses from the trial are qualitative. [2]

.....
.....
.....
.....

(c) Explain why a designer might choose to represent qualitative information from the trial quantitatively. [3]

.....
.....
.....
.....
.....
.....
.....
.....

(Option E continues on the following page)



(Option E continued)

26. (a) Define *paper prototype* in the context of developing the human/computer interface for a mobile phone. [1]

.....
.....

- (b) Outline the role of the facilitator in a paper prototyping session. [2]

.....
.....
.....
.....

(Option E continues on the following page)



(Option E continued)

- 27. **Figure E2** shows an ironing board adjustable to three different height positions. The same model is available in three different board widths.

Figure E2: Height adjustable ironing board



[Source: Brabantia ironing board]

- (a) Outline which percentiles the designer would use for the three height positions of the ironing board. [2]

.....
.....
.....
.....

- (b) Outline **one** reason for providing the ironing board in three different board widths. [2]

.....
.....
.....
.....

(Option E continues on the following page)



(Option E continued)

28. Outline why representative dynamic anthropometric data is difficult to obtain. [2]

.....

.....

.....

.....

29. Suggest **two** ways in which human factors specialists determine adequate product safety. [6]

.....

.....

.....

.....

.....

.....

.....

.....

.....

.....

.....

.....

.....

.....

.....

.....

.....

.....

.....

.....

.....

(Option E continues on the following page)



32EP29

Turn over

Please **do not** write on this page.

Answers written on this page
will not be marked.



32EP31

Please **do not** write on this page.

Answers written on this page
will not be marked.



32EP32