



MARKSCHEME

May 2011

DESIGN TECHNOLOGY

Standard Level

Paper 3

*This markscheme is **confidential** and for the exclusive use of examiners in this examination session.*

*It is the property of the International Baccalaureate and must **not** be reproduced or distributed to any other person without the authorization of IB Cardiff.*

If you do not have a copy of the current Design Technology Guide,
please request one from IB Cardiff.

General Marking Instructions

Assistant Examiners (AEs) will be contacted by their team leader (TL) by e-mail (or telephone) – if by e-mail, please reply to confirm that you have downloaded the markscheme from IBIS. The purpose of this initial contact is to allow AEs to raise any queries they have regarding the markscheme and its interpretation. AEs should contact their team leader by e-mail at any time if they have any problems/queries during the marking process.

Note:

The DHL courier service must be used to send assessment material to your team leader/senior moderator and to IB Cardiff. (However, this service is not available in every country.) The cost is met directly by the IB. It is vitally important that the correct DHL account number is used.

If you have any queries on **administration** please contact:

Risha Ali
Assessment Operations Department (AOD)
IB Cardiff
Peterson House
Malthouse Avenue
Cardiff Gate
Cardiff CF23 8GL
GREAT BRITAIN

Tel: +(44) 29 2054 7777

Fax: +(44) 29 2054 7778

E-mail: risha.ali@ibo.org

1. Follow the markscheme provided, award only whole marks and mark only in **RED**.
2. Where a mark is awarded, a tick/check (✓) **must** be placed in the text at the **precise point** where it becomes clear that the candidate deserves the mark. **One tick to be shown for each mark awarded.**
3. Sometimes, careful consideration is required to decide whether or not to award a mark. In these cases write a brief annotation to explain your decision. You are encouraged to write comments where it helps clarity, especially for moderation and re-marking. It should be remembered that the script may be returned to the candidate.
4. Unexplained symbols or personal codes/notations are unacceptable.
5. Record marks in the right-hand margin against each mark allocation shown in square brackets *e.g. [2]*. The total mark for a question must equal the number of ticks for the question.
6. Do **not** circle sub-totals. **Circle the total mark** for the question in the right-hand margin **at the end of the question.**
7. Where an answer to a part question is worth no marks, put a zero in the right-hand margin next to the square bracket.
8. Where work is submitted on additional sheets the marks awarded should be shown as ticks and a note made on both the additional sheet and in the right-hand margin of the corresponding question part in the body of the script.
9. For each Option: Add the totals for each question in the Option and write it in the Examiner column on the cover sheet.
Total: Add the marks awarded and enter this in the box marked TOTAL in the Examiner column on the cover sheet.
10. After entering the marks on the cover sheet check your addition to ensure that you have not made an error. Check also that you have transferred the marks correctly to the cover sheet. **All scripts are checked and a note of all clerical errors will be given in feedback to examiners.**
11. If an answer extends over more than one page and no marks have been awarded on a section draw a diagonal line through that section to indicate that it has been marked.
12. If a candidate has attempted more than the required number of questions within a paper or section of a paper, mark all the answers and use the marks of those answers that have the highest mark, **even if the candidate has indicated the question(s) to be marked on the cover sheet.**
13. Mark positively. Give candidates credit for what they have achieved and for what they have got correct, rather than penalizing them for what they have got wrong. A mark should not be awarded where there is contradiction within an answer. Make a comment to this effect in the left hand margin.

Subject Details: Design Technology SL Paper 3 Markscheme

Mark Allocation

Candidates are required to answer questions from **ONE** of the Options [**1 × 30 marks**].

Maximum total = [**30 marks**]

1. A markscheme often has more marking points than the total allows. This is intentional. Do **not** award more than the maximum marks allowed for part of a question.
2. Each marking point has a separate line and the end is signified by means of a semicolon (;).
3. An alternative answer or wording is indicated in the markscheme by a slash (/) – either wording can be accepted.
4. Words in brackets () in the markscheme are not necessary to gain the mark.
5. Words that are underlined are essential for the mark.
6. The order of marking points does not have to be as in the markscheme, unless stated otherwise.
7. If the candidate's answer has the same “meaning” or can be clearly interpreted as being of equivalent significance, detail and validity as that in the markscheme then award the mark. Where this point is considered to be particularly relevant in a question it is emphasized by writing **OWTTE** (or words to that effect).
8. Remember that many candidates are writing in a second language. Effective communication is more important than grammatical accuracy.
9. Occasionally, a part of a question may require an answer that is required for subsequent marking points. If an error is made in the first marking point then it should be penalized. However, if the incorrect answer is used correctly in subsequent marking points then **follow through** marks should be awarded. Indicate this with **ECF** (error carried forward).
10. Only consider units at the end of a calculation. Unless directed otherwise in the markscheme, unit errors should only be penalized once in the paper. Indicate this by writing **-1(U)** at the first point it occurs and **U** on the cover page.
11. Do not penalize candidates for errors in significant figures unless it is specifically referred to in the markscheme.

Option A — Food science and technology

A1. (a) *Award [1] for stating the percentage of the GDA for energy for an average adult woman provided by a cheeseburger, large fries and medium chocolate milkshake meal.*

$$15 + 23 + 21 = 59 \%$$

$$1170/2000 = 58.5 \%$$

[1 max]

(b) *Award [1] for each point in an outline of one reason why a balanced diet should contain fat [2 max].*

fat acts as a vehicle to help the absorption of fat-soluble vitamins;

these prevent fat-soluble vitamin deficiencies;

fat provides energy;

low fat diets may not provide enough energy;

some fatty acids are essential;

they cannot be produced by the body and must be provided by the diet for health; **[2 max]**

(c) *Award [1] for each of three distinct correct points in an explanation of one implication of excess fat intake for health [3 max].*

high dietary fat intakes, especially of saturated fat, can lead to increased levels of cholesterol;

this can lead to coronary heart disease/obesity;

resulting in poor health;

[3]

- A2.** (a) *Award [1] for stating the range of body mass index (BMI) that is considered to be overweight.*
25–29.9; [1]
- (b) *Award [1] for each point in an outline of one limitation of using BMI as a health indicator [2 max].*
BMI measures total body weight not the amount of fat a person is carrying;
fat may not be responsible for the weight they carry;
- athletes, *e.g.* rugby players and weight lifters, and people who are naturally stocky often have a BMI indicating they are overweight;
their BMI is higher due to extra muscle/bone mass not because of excess body fat;
- some athletes, *e.g.* long distance runners, will be underweight according to their BMI;
this is due to low body fat and aerobic slow twitch muscle fibres, which develop naturally as a result of their particular sport;
- elderly people and people who have been ill may have lost muscle mass;
they will appear to be underweight although it is normal to lose muscle mass/body fat in old age/poor health;
- a BMI in the normal range does not necessarily indicate someone is in good health;
they may also be carrying more body fat than is good for them; [2 max]
- A3.** (a) *Award [1] for stating the type of spoilage and [1] for a brief explanation [2 max].*
microbiological spoilage;
mould/fungus is growing on the tomato; [2]
- (b) *Award [1] for each point in an outline of how sun drying of tomatoes can be used to preserve them [2 max].*
lowers water activity/reduces water content;
this prevents bacterial growth; [2]
- A4.** *Award [1] for each point in an outline of one important consideration relating to the selection of the members of a taste panel [2 max].*
taste panel members must match the target market for the product, *e.g.* children or adults;
foods designed for one target market may not suit the taste of other markets; [2]

A5. Award [1] for each of three distinct correct points in an explanation of each of two distinct lifestyle issues which have contributed to the growing market for organic products in some countries [3 max] per issue [6 max].

increased health awareness and concerns about food scares, e.g. mad cow disease, salmonella in eggs;

people are more interested/concerned about where food comes from;
organic products often have a known provenance;

fashion and media influences;
it is “cool” to be organic;
makes a statement (ideopleasure);

ethical considerations;
concerns about factory farming and animal rights issues;
organic produce seen to be more appropriate;

supermarkets have promoted organic produce;
this gives it a higher consumer profile;
although more expensive, people are prepared to pay a premium for organic products as they are perceived to be better;

increase in leisure time;
more people have the opportunity to grow produce;
and guidance is readily available;

taste/flavour;
many consumers think that organic produce tastes better;
because they grow under natural conditions;

marketing of “grow your own” kits by DIY stores *etc.*;
encourages consumers to produce their own food;
by providing seeds/plants in containers with nutrients/instructions;

[6 max]

A6. Award [1] for each of three distinct points in an explanation of each of three reasons for the increased incidence of food allergies and food intolerance in developed countries [3 max] for each factor [9 max].

better diagnosis of food intolerance;
provides better data on food intolerance;
although still may be underestimating extent of food intolerance;

people eat a wider range of foods than they may have done previously;
travel, the media, availability of different foods has increased;
foods introduced later in life may cause more problems than those introduced early in life;

increased use of food additives/more exposure to environmental chemicals;
trigger allergic reactions;
results in increased food allergies/intolerance;

increased sanitation;
results in removal of helpful bacteria from environment and gut;
probiotic bacteria, e.g. from probiotic yogurt, may improve food/lactose tolerance;

genetics;
allergies handed down from generation to generation;
creates an on-going problem;

increase in manufacture of processed foods;
with traces/ingredients of trigger foods;
e.g. nuts/dairy;

[9 max]

Option B – Electronic product design

B1. (a) Award [1] for stating the logic gate required for the security system.
OR gate; [1]

(b) Award [1] for including all eight input combinations (in any order) and [1] for only having a 0 when all inputs are 0 [2 max].

A	B	C	Q
0	0	0	0
0	0	1	1
0	1	0	1
0	1	1	1
1	0	0	1
1	0	1	1
1	1	0	1
1	1	1	1

[2 max]

(c) Award [1] for using the correct symbol for a push switch, [1] for labelling of 0V, 5V and output A and [1] for use of a pull down resistor (any value) [3 max].

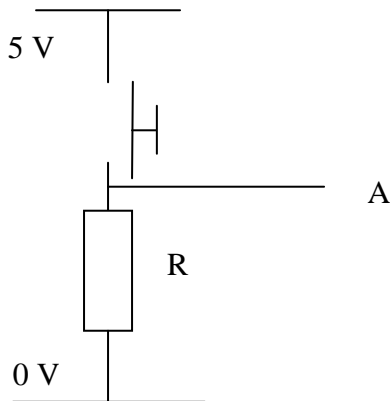

[3 max]

B2. (a) Award [1] for stating the correct answer with units.
 $P=V.I$ so $I = P/V = 3/6 = 0.5$ amperes/0.5 A; [1]

(b) Award [1] for stating each of two reasons why solar cell technology is particularly suitable for remote areas in developing countries [2 max].

- no national grid;
- no running costs (fuel/batteries/etc.);
- no maintenance required;

[2 max]

- B3.** (a) *Award [1] for each point in an outline of one difference between a digital and an analogue signal [2 max].*
an analogue signal is continuously varying and can take any value;
a digital signal takes discrete steps/can be represented as a binary number is on or off/0 or 1; [2]
- (b) *Award [1] for each point in an outline of one reason why a Schmitt trigger NOT gate is more suitable than a standard NOT gate when converting an analogue signal to a digital signal [2 max].*
a Schmitt trigger has a dead band;
it does not respond to small changes that might happen with an analogue signal; [2]
- B4.** *Award [1] for each of two reasons why programmable interface controllers (PICs) are present in many modern electronic products [2 max].*
versatility;
low cost;
low power;
upgradeability; [2 max]
- B5.** *Award [1] for each distinct correct point in a discussion of one advantage and one disadvantage for an Internet service provider operating a satellite-based rather than an optical fibre-based system [3 max] for an advantage and [3 max] for a disadvantage, [6 max] in total.*
Advantage [3 max]:
satellite footprint gives coverage in remote areas;
does not have to be laid over terrain physically;
footprint can be moved easily according to need;
- Disadvantage [3 max]:*
cost/satellite systems are expensive;
the antenna must be accurately pointed at the satellite;
they can be disrupted by bad weather; [6 max]

B6. Award [1] for each of three distinct correct points in an explanation of the importance of global standards for digital electronic products and [1] for each of three distinct correct points in an explanation of the benefits for users and [1] for each of three distinct correct points in an explanation of the benefits for manufacturers [3 max] for each way [9 max].

The importance of global standards for digital electronic products [3 max]:

- reduces signals to binary/0s and 1s;
- generic standards;
- supports converging technology;

Benefits for users [3 max]:

- reduced costs of products;
- increased versatility;
- a variety of devices can communicate exchange data (e.g. computer, phone, camera, personal organiser, a variety of music players, hand held GPS);
- increased functionality;

Benefits for manufacturers [3 max]:

- reduce development costs/increases interoperability of different devices;
- reduced material costs;
- reduced distribution costs;

- reduced need for holding stocks of a wide range of components;
- removes delays in production;
- reduces warehousing costs;
- reduces money tied up in stock;

[9 max]

Option C – CAD/CAM

- C1.** (a) *Award [1] for stating one advantage of wire frame modelling for the manufacturer.*
can see internal design structure of the ring;
relatively simple model;
fast to produce and modify;
can rotate the object to new desired views;
can see how the diamond is fitted into the setting;
provides coordinates for CAM; **[1 max]**
- (b) *Award [1] for each point in an outline of one advantage of the solid model for the client [2 max].*
good communication tool with non-specialist audience;
the customer can see exactly what the ring will look like;
can see how different stones would look in the ring;
can explore options without using resources;
the design can be “tweaked” and new images produced quickly;
the designer and the customer can discuss the design/the customer becomes part of the design team; **[2 max]**
- (c) *Award [1] for each of three distinct correct points in an explanation of one implication of the use of the CAD model of the ring for cost effectiveness of production [3 max].*
reduction in tooling costs/labour costs/energy costs/material costs;
ring can be produced virtually and discussed with client;
ring only produced after design confirmed;
- links to CAM;
production costs minimized;
there are no test pieces;
- supports mass customization;
ring design can be resized easily and customized to the client’s specific requirements;
different options for surface textures/materials/stones can be explored; **[3 max]**

- C2.** (a) *Award [1] for stating one limitation of using a three-axis machine when making a product.*
product resulting from use of a three-axis machine will have a flat base;
cannot do undercuts; **[1 max]**
- (b) *Award [1] for each point in an outline of one advantage of using a three-axis machine over using a 5-axis machine when making a product [2 max].*
more cost-effective;
5-axis machines are usually very expensive; **[2 max]**
- C3.** (a) *Award [1] for each of two distinct correct points in a description of what the colours on Figure C2 mean [2 max].*
red bits indicate high stresses;
blue/green bits indicate low stresses; **[2]**
- (b) *Award [1] for each point in an outline of how the FEA image data shown in Figure C2 would be used by a designer [2 max].*
the design would be modified;
to reduce the stresses to ensure product safety; **[2]**
- C4.** *Award [1] for identifying one subtractive manufacturing technique and [1] for a brief explanation [2 max].*
milling/routing/sanding/cutting/use of lathe (e.g. laser cutting, knives, hot wires, arc cutting, plasma cutting, plotter cutting);
removes material from a block to produce shape required; **[2]**

C5. Award [1] for each point in an explanation of each of two limitations of being able to rapid prototype the object in Figure C3 by using LOM rather than other rapid prototyping techniques [3 max] per limitation [6 max].

internal structure of a product;

cannot be represented using LOM;

appearance prototyping not functional prototyping;

number of components;

LOM more effective where number of components small;

not good for complex products;

poor surface finish;

need for further treatment to get good surface finish;

e.g. sanding;

takes a long time to assemble;

stair stepping between layers;

can cut material at an angle to avoid this;

[6 max]

C6. Award [1] for each of three distinct correct points in a discussion of the use of computer-integrated manufacture (CIM) for a car manufacturer [3 max] for each of three advantages/disadvantages [9 max].

Advantages:

can operate just-in-time (JIT) system;
raw materials/third part components ordered to requirements;
no need for storage facilities (parts/products);

vehicle produced to customer order and specification;
keeps costs down;
makes car manufacturer more competitive in the market-place;

assembly checked for quality throughout;
removes errors;
reduces wastage;

complete process controlled by machines;
reduces labour costs;
makes car manufacturer more competitive in the market-place;

customer satisfaction;
more opportunities for customization;
reduces lead time and distribution to customer;

Disadvantages:

set-up costs are high;
redundancy costs high;
(re)training costs are high;
has to be seen as a long-term investment;

integration of machines from different suppliers into CIM system can be problematic;
different machines (such as CNC, conveyors and robots) use different communication protocols;
different machines may have different maintenance requirements, e.g. lengths of time for charging/changing the batteries;

staff morale;
data integrity for machine control is critical;
needs highly-skilled people to ensure proper safeguards for system;
jobs are very different;
causes redundancy/(re)training;

reliability;
CIM is a highly complex system;
failure of any part of the system undermines consumer confidence/the whole process; [9 max]

Option D – Textiles

- D1.** (a) *Award [1] for stating one aspect of the specification of the material for the kite.*
high strength to weight ratio;
does not stretch much;
not water absorbent;
fray resistant;
does not rip;
easy to cut/join
available in a wide range of colours/able to be dyed any colour; **[1 max]**
- (b) *Award [1] for each point in an outline of one aesthetic consideration which makes nylon a suitable material for use in the production of the kite [2 max].*
the kite requires a brightly coloured material;
nylon fibres can be produced in a range of colours;

designs are often printed on the material;
nylon can easily be printed on; **[2 max]**
- (c) *Award [1] for each of three distinct correct points in an explanation of how ripstop characteristics are manufactured into the material [3 max].*
ripstop nylon has reinforcement threads in a crosshatch pattern;
or by weaving two or three fine yarns together at intervals;
this prevents tears/rips in the material from spreading; **[3]**
- D2.** (a) *Award [1] for stating one natural fibre that can be used for lace-making.*
cotton;
silk; **[1]**
- (b) *Award [1] for each point in an outline of one disadvantage of using lace for producing a tablecloth [2 max].*
uneven surface;
so objects placed on the tablecloth will be unstable;

full of holes;
so liquids pass through and can damage surface underneath;

difficult to launder;
not practical as a tablecloth is likely to need laundering very often;

delicate fabric;
easy to damage;

difficult to iron;
due to uneven surface/delicate fabric; **[2 max]**

- D3.** (a) *Award [1] for each of two distinct correct points in a description of the sublimation printing process [2 max].*
dyes printed onto fabric;
heat is applied so the dyes sublime (change from solid to gas without passing through a liquid phase) and image formed; [2]
- (b) *Award [1] for each point in an outline of one limitation of using the sublimation printing process [2 max].*
durability;
the image fades over time as the dye washes out of the fabric;

image quality;
a slight blurriness at the edge of a colour results from diffusion of the gaseous dye through the fabric;

substrate material;
can print directly onto fabric; [2 max]
- D4.** *Award [1] for each of two distinct correct points in a description of the purpose of spinning when making yarn [2 max].*
spinning twists the textile fibres into a continuous thread by hand/by using a spinning wheel;
the thread can be spun thick/thin/plyed/unplyed;
the thread will be stronger once spun;
it will be an even thickness; [2 max]
- D5.** *Award [1] for each distinct correct point in an explanation of each of two issues relating to the manufacture of silk substitutes [3 max] per issue, [6 max].*
silk has unique material properties;
aesthetics/look/feel/drape/absorbency/physiopleasure/comfort/quality;
silk substitutes are inferior and do not have the same material properties;

cost;
although silk substitutes are cheaper;
they do not have the same quality;

there is an elite status associated with silk;
silk was originally only allowed for use by ruling class in China;
its cost has maintained its status;

impact on the silk industry;
traditional skills/practices declining;
due to the reduced market for silk; [6 max]

D6. *Award [1] for each of three distinct correct points in a discussion of each of three ways in which the use of CAD/CAM in the textile industry has helped to minimize waste [3 max] for each way [9 max].*

facilitates the production of complex designs;
facilitates the development and resizing of designs;
no need for pattern pieces;

quality control;
precision cutting;
lower tolerance on components;
eliminates human error;

tessellation of product components;
more components produced per length of fabric;
maximises the conversion of raw material into product/reduces waste;

allows for mass customization/JIT;
products made to order;
no waste as products paid for prior to production so no obsolete shop stock;

[9 max]

Option E – Human factors design

- E1.** (a) *Award [1] for stating which part of the human information processing system is represented by a physiological action.*
motor processes/output; [1]
- (b) *Award [1] for each of two distinct correct points in a description of the sensory process in the human information-processing system [2 max].*
eyes take in information;
send information to brain for processing; [2]
- (c) *Award [1] for each of three distinct correct points in an explanation of the function of memory in the human information-processing system [3 max].*
information from the sensory processes needs to be stored temporarily;
in order for the brain to decide on what action is to be taken;
before it sends the information to the motor process; [3]
- E2.** (a) *Award [1] for a definition of user population to the effect of:*
range of users for a particular product or system; [1]
- (b) *Award [1] for each of two distinct correct points in a description of the “method of extremes” to limit sample sizes [2 max].*
sample users are selected to represent the extremes of the user population/largest/smallest/lightest/heaviest;
a small number of intermediate values may then be used; [2 max]
- E3.** (a) *Award [1] for each point in an outline of one reason related to human factors for the size of the lenses of the Ad-specs [2 max].*
one size fits all;
large size chosen so suitable for all users/uses; [2]
- (b) *Award [1] for each point in an outline of one aspect of the design of the spectacles which has been compromised by the size of the lenses [2 max].*
aesthetics/style;
the Ad-specs are functional not decorative; [2]
- E4.** *Award [1] for each of two distinct correct points in a description of why mapping is an important consideration in human factors design [2 max].*
mapping relates to the correspondence between the layout of a product and its controls;
enables a product to be used intuitively; [2]

E5. Award [1] for each of three distinct correct points in an explanation of each of two physiological human factors issues in relation to the Forest chair [3 max] per factor, [6 max].

comfort;

metal provides a hard surface to the chair;

this may make the chair uncomfortable when sitting for a long time;

the chair may feel very hot/cold depending on the weather conditions;

metal is a very good conductor of heat;

this may make the chair feel uncomfortable when first sitting down;

safety;

the holes could snag clothing;

or pinch the skin/become finger traps for children;

ease-of-use for elderly/infirm people;

the sides of the chair are made from thin metal;

this does not provide much support for hands when a user is pushing him/herself out of the chair;

shape;

the chair is designed to support the back/hips;

but may not be suitable for very large people to fit in it;

[6 max]

E6. Award [1] for each of three distinct correct points in each of three safety issues concerning the use of the grill [3 max] for each advantage [9 max].

height of the grill;

may not be at eye level for all users;

some users may have to stand on tip-toe to see if food cooked;

accidents more likely to happen;

eye-level means that the face and eyes are at the same height as the grill;

hot fat may spit out from the grill;

could hit eyes/face and cause injury;

with the grill at eye-level;

smoke from the grill could get into the eyes;

this may cause an accident;

to use the grill pan;

users have to hold the grill at head height;

this puts strain on the arm;

grill pan handle;

could get hot as near the heat source;

so burn the skin of the user;

pulling the grill pan from the grill with hot grilled food;

puts strain on muscles;

could cause an accident;

[9 max]
