

INTERNATIONAL
BACCALAURÉAT
BACHILLERATO



BACCALAUREATE
INTERNATIONAL
INTERNACIONAL

M04/470/S(2)M

MARKSCHEME

May 2004

DESIGN TECHNOLOGY

Standard Level

Paper 2

*This markscheme is **confidential** and for the exclusive use of examiners in this examination session.*

*It is the property of the International Baccalaureate and must **not** be reproduced or distributed to any other person without the authorisation of IBCA.*

If you do not have a copy of the current Design Technology Guide,
please request one from IBCA.

General Marking Instructions

*After marking a sufficient number of scripts to become familiar with the markscheme and candidates' responses to all or the majority of questions, Assistant Examiners (AEs) will be contacted by their Team Leader (TL) by telephone. The purpose of this contact is to discuss the standard of marking, the interpretation of the markscheme and any difficulties with particular questions. It may be necessary to review your initial marking after contacting your TL. **DO NOT BEGIN THE FINAL MARKING OF YOUR SCRIPTS IN RED INK UNTIL YOU RECEIVE NOTIFICATION THAT THE MARKSCHEME IS FINALISED.** You will be informed by e-mail, fax or post of modifications to the markscheme and should receive these about one week after the date of the examination. If you have not received them within 10 days you should contact your Team Leader by telephone. Make an allowance for any difference in time zone before calling. **AEs WHO DO NOT COMPLY WITH THESE INSTRUCTIONS MAY NOT BE INVITED TO MARK IN FUTURE SESSIONS.***

You should contact the TL whose name appears on your 'Allocation of Schools listing' sheet.

Note:

Please use a personal courier service when sending sample materials to TLs unless postal services can be guaranteed. Record the costs on your examiner claim form.

1. Follow the markscheme provided, do **not** use decimals or fractions and mark only in **RED**.
2. Where a mark is awarded, a tick (✓) should be placed in the text at the **precise point** where it becomes clear that the candidate deserves the mark.
3. Sometimes, careful consideration is required to decide whether or not to award a mark. In these cases write a brief annotation in the **left hand margin** to explain your decision. You are encouraged to write comments where it helps clarity, especially for moderation and re-marking.
4. Unexplained symbols or personal codes/notations on their own are unacceptable.
5. Record subtotals (where applicable) in the right-hand margin against the part of the answer to which they refer (next to the mark allocation for Section A). Do **not** circle sub-totals. **Circle the total mark for the question in the right-hand margin opposite the last line of the answer.**
6. For Section B, show a mark for each part question (a), (b), *etc.*
7. Where an answer to a part question is worth no marks, put a zero in the right-hand margin.
8. Section A: Add together the total for each question and write it in the Examiner Column on the cover sheet.
Section B: Insert the total for each question in Examiner Column on the cover sheet.
Total: Add up the marks awarded and enter this in the box marked TOTAL in the Examiner Column on the cover sheet.
9. After entering the marks on the cover sheet check your addition to ensure that you have not made an error. Check also that you have transferred the marks correctly to the cover sheet. **We have script checking and a note of all clerical errors may be given in feedback to examiners.**
10. Every page and every question must have an indication that you have marked it. Do this by **writing your initials** on each page where you have made no other mark.
11. If a candidate has attempted more than the required number of questions within a paper or section of a paper, mark only the required number of questions in the order in which they are presented in the paper, unless the candidate has indicated the question(s) s/he wants to be marked on the cover sheet.
12. A candidate can be penalised if he/she clearly contradicts him/herself within an answer. Make a comment to this effect in the left hand margin.

Subject Details: Design Technology SL Paper 2 Markscheme

Mark Allocation

Candidates are required to answer **ALL** questions in Section A (total 20 marks) **and any ONE** question in Section B (20 marks each). Maximum total = 40 marks.

General

A markscheme often has more specific points worthy of a mark than the total allows (especially for essay questions). This is intentional. Do not award more than the maximum marks allowed for part of a question.

When deciding upon alternative answers by candidates to those given in the markscheme, consider the following points:

- Each marking point has a separate line and the end is signified by means of a semicolon (;).
- An alternative answer or wording is indicated in the markscheme by a '/'; either wording can be accepted.
- Words in (...) in the markscheme are not necessary to gain the mark.
- The order of points does not have to be as written (unless stated otherwise).
- If the candidate's answer has the same 'meaning' or can be clearly interpreted as being the same as that in the mark scheme then award the mark.
- Mark positively. Give candidates credit for what they have achieved, and for what they have got correct, rather than penalising them for what they have not achieved or what they have got wrong.
- Remember that many candidates are writing in a second language; be forgiving of minor linguistic slips. Effective communication is more important than grammatical niceties.
- Occasionally, a part of a question may require a calculation whose answer is required for subsequent parts. If an error is made in the first part then it should be penalised. However, if the incorrect answer is used correctly in subsequent parts then **follow through** marks should be awarded. Indicate this with '**ECF**', error carried forward.
- Units should always be given where appropriate. Omission of units should only be penalised once. Indicate this by '**U-1**' at the first point it occurs. Ignore this, if marks for units are already specified in the markscheme.
- Do not penalize candidates for errors in significant figures, unless it is specifically referred to in the markscheme.

SECTION A

1. (a) (i) *Award [1] for:*
The length of the ruler/220 mm/22 cm *[1 max]*

(ii) *Award [1] for:*
160 mm/16 cm *[1 max]*

(iii) *Award [1] for identifying correct values, and for identifying how to do the calculation and [1] for correct answer including units.*
160/2;
breadth of set square = 80 mm; *[2 max]*

(b) (i) *Award [1] for placing the pencil along length of net next to protractor above the set square, as shown below (X). Award [1] for placing the eraser in the space between the pencil and the ruler as shown below (Y).* *[2 max]*

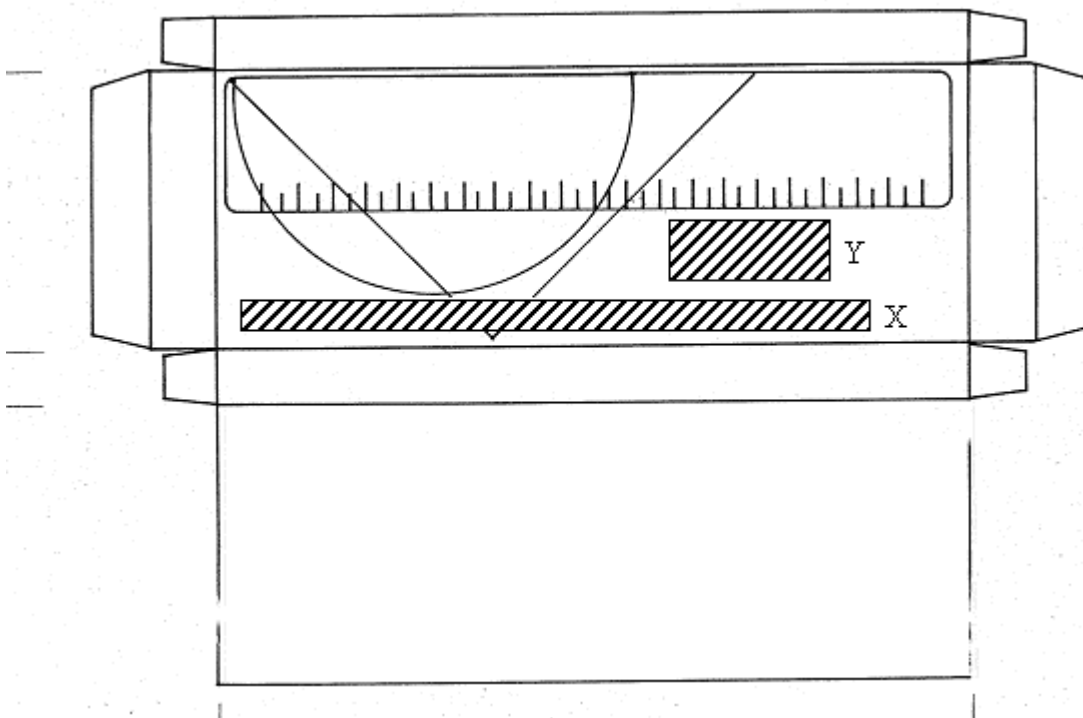

(ii) *Award [1] per distinct point:*
The depth of the pencil and the protractor is $3.5 + 6.5 = 10$ mm; and
the depth of the eraser is 11 mm, so the minimum depth for the box
is 11 mm; *[2 max]*

- (c) (i) Award [1] for adding a flap to the box either as A or B (see below): [1 max]

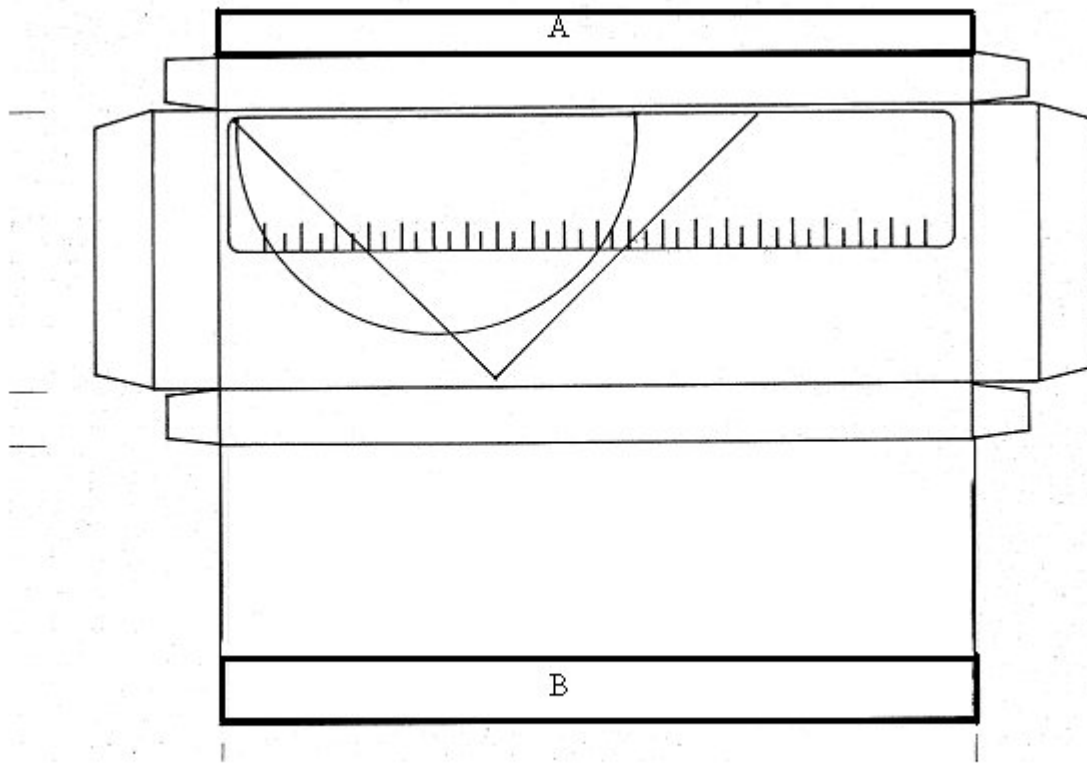

- (ii) Award [1] for cutting the shape of the net from the thin card.
Award [1] for folding the package into shape.
Award [1] for gluing or stapling flaps to the box to maintain the package.

[3 max]

2. (a) *Award [1] for identifying an appropriate mechanical property and [1] for a brief explanation, [2 max].*
High toughness;
to overcome its susceptibility to the propagation of cracks during wasting;
Hardness;
To enable it to be abraded;
High stiffness;
So it can be sawn; **[2 max]**
- (b) *Award [1] for identifying an appropriate aesthetic property and [1] for a brief explanation, [2 max].*
Texture;
fine grain so it can be abraded to a smooth finish;
fine grain;
so it can be abraded to a smooth finish;
natural colour;
appealing to children;
attractive grain;
aesthetically pleasing/reminiscent of traditional houses; **[2 max]**
3. (a) *Award [1] for a definition to the effect of:*
Building a thicker layer of material using a number of thinner layers of material joined with adhesives.
Do not award a mark for a description of veneering, **[1 max]**
- (b) *Award [1] for each appropriate advantage of lamination [3 max].*
No finishing required;
Able to form complex shapes and surfaces;
Able to combine different materials;
Can be used to create large surfaces;
Produces very strong composite materials;
Can overcome problems of grain;
Produces high strength to weight characteristics; **[3 max]**

SECTION B

4. (a) (i) *Award [1] for a definition to the effect of:*
(Using creative ability for) producing a wide range of possible solutions to a problem/thinking outside the box. *[1 max]*
- (ii) *Award [1] for identifying one way in which constructive discontent contributes to the re-design of a refrigerator-freezer and [1] for a brief explanation [2 max].*
Evaluation of a design can identify weaknesses;
in redesigning the product these weaknesses can be addressed; *[2 max]*
- (iii) *Award [1] for identifying an appropriate stage where orthographic drawings would be relevant, [1] for brief explanation of why they would be used [2 max].*
Orthographic drawings would be used in the final solution stage;
to communicate design detail from designer to manufacturer; *[2 max]*
- (b) (i) *Award [1] for identifying one disadvantage and [1] for a brief explanation [2 max].*
Products are worth less; reduces likelihood for secondhand market;
Products need to be replaced more often;
pushes up cost of product ownership; *[2 max]*
- (ii) *Award [1] for identifying how planned obsolescence influences the design specification and [1] for brief explanation, [2 max].*
Materials specification;
cheaper materials might be used although they need to be carefully selected to ensure they are “good enough” for anticipated product life;
- Assembly method;
products may be assembled in a way which does not make them repairable;
- Materials specification;
recyclable materials might be used to maximize recycling potential;
- Assembly method;
products may be assembled in a way which makes them easy to disassemble so materials can be recycled;
- Motor life;
would be specified to match planned life of product; *[2 max]*

- (c) (i) *Award [1] for each distinct point in an explanation of how fixed costs contribute to the final cost of the refrigerator-freezer [2 max].*
The likely volume of product to be manufactured is determined/a breakeven point is decided by the manufacturer;
A proportion of the fixed costs are recovered through the selling cost of each individual item; **[2 max]**
- (ii) *Award [1] for each distinct point up to [3 max] for each of three benefits of ecolabelling schemes over the energy label shown in Figure 4 [9 max].*
Energy labeling only considers energy during use of the product;
Energy used at other stages of lifecycle are not considered;
Energy used in manufacture or distribution may be very high;

Consideration of end disposal of product is not considered by energy labels;
e.g. recycling potential is not considered;
Environmental impact of product disposal, *e.g.* due to toxic materials, not considered;

Energy labels do not consider mode of manufacture/use of clean technologies during manufacture;
Non-adoption of clean technologies may result in material wastage during manufacture;
Pollution may be high during manufacture;

Environmental impact of distribution not considered;
Inappropriate packaging, *e.g.* non-recyclable materials or plastic packaging with high environmental impact, may result in major environmental impact;
Use of recycled materials for packaging and minimal packaging approaches are not encouraged by energy labeling; **[9 max]**

5. (a) (i) *Award [1] for identifying one way in which brainstorming might be used in the re-design of a washing machine and [1] for a brief explanation [2 max].*
Sharing ideas with other designers or product users can highlight design opportunities;
in redesigning the product these opportunities can be developed; **[2 max]**
- (ii) *Award [1] for identifying an appropriate stage where freehand drawings would be relevant, [1] for brief explanation [2 max].*
Used in the generating ideas stage; to communicate design ideas from designers to other designers or consumers/to explore shape and form; **[2 max]**
- (b) (i) *Award [1] for a definition to the effect of:*
The proportion of a population with a dimension at or less than a given value. **[1 max]**
- (ii) *Award [1] for each distinct point in explanation of why data for 50th percentile female is widely used in design of kitchen appliances [2 max].*
Kitchen appliances are of fixed size and unless specially designed/adapted need to be able to be used by most people in adult population, hence use of 50th percentile;
women are more likely to use kitchen appliances than men (despite issues of political correctness and need to be safe in use, e.g. not forcing people to overreach and impacting on potential safety therefore a bias towards female data where appropriate; **[2 max]**
- (iii) *Award [1] for identifying how fashion influences the design specification and [1] for brief explanation, [2 max].*
Fashion increases product consumption;
unless only recycled materials and renewable energy sources are used this will result in increased consumption of natural resources; **[2 max]**

- (c) (i) *Award [1] for each distinct point in an explanation of how industrial robots contribute to the flexibility of manufacture [2 max].*
Can be fairly easily reprogrammed;
to undertake different tasks/to produce variations in the product that better meet user requirements; **[2 max]**
- (ii) *Award [1] for each distinct point up to [3 max] for each of three benefits of adopting a proactive environmental policy for a washing machine manufacturer [9 max].*
A proactive environmental policy would:
- Promote the more efficient use of energy;
Saves money;
Reduces pollution;
Enhances brand image; **[3 max]**
- Promote the more efficient use of materials, *e.g.* recycled materials;
Reduce consumption of virgin natural resources;
Reduce production of waste for disposal on landfill sites;
More profit or more competitive price; **[3 max]**
- Appeal to more eco-conscious consumers;
Increase market share;
Lead to increased profits; **[3 max]**
- Promote the adoption of clean technologies;
Reduce atmospheric and other pollution;
Reduce wastage of raw materials; **[3 max]**
- Reduces pollution;
Reduces risk of being fined for causing pollution;
Can lead to competitive advantage; **[3 max]**
- Ensures continuity of production;
Company can adapt to changes in own timescale, rather than being forced to react by government;
Keeps company in control rather than being driven by legislation; **[3 max]**
- [9 max]**

6. (a) (i) *Award [1] for identifying one disadvantage of using a performance test to evaluate car safety and [1] for a brief explanation [2 max].*
Time consuming;
to get a reliable and reproducible result;
- Costly to perform;
expensive set up costs, e.g. cost of sensors/destructive test/car irreparably damages in test;
- May be difficult to relate the results to the way that the product is really used (and abused);
thus data not reflective of real scenarios;
- Model of person does not provide the true scenario; *[2 max]*
therefore limited reliability;
- (ii) *Award [1] for identifying an example of where bodily tolerances are relevant to the collection of data [1] for brief explanation [2 max].*
Fatigue;
when people get tired they react in different ways;
- Comfort;
is a qualitative consideration and differs massively between different people; *[2 max]*
- (b) (i) *Award [1] for a definition to the effect of:*
Small changes to the design of a product that individually seem trivial but cumulatively are significant. *[1 max]*
- (ii) *Award [1] for why the design is radical and [1] for why it is incremental [2 max].*
Incorporation of radical elements, e.g. one element redesigned in terms of materials/technologies/mode of manufacture;
are against a backdrop of small but significant changes to the other elements of the car; *[2 max]*
- (iii) *Award [1] for one advantage of producing a physical model and [1] for brief explanation, [2 max].*
Consumers can see size, shape of car easily;
other methods of design communication rely on the ability of the consumer to interpret the model;
- Some physical models can be handled;
therefore ergonomic considerations can be better assessed; *[2 max]*

- (c) (i) *Award [1] for each distinct point in an explanation of how cars can be considered as in the mature stage of their life cycle [2 max].*

Cars have diffused well into market, have gained acceptance and are selling well;

there are no signs of decline in sales;

[2 max]

- (ii) *Award [1] for each distinct point plus [1] for each distinct point in an explanation [3 max] for each of three benefits of adopting clean technologies in car production [9 max].*

Increased efficiency in the use of raw materials;

Saves money;

Reduces consumption of natural resources;

Increased efficiency in use of energy;

Saves money;

Reduces atmospheric and other pollution;

Minimizing environmental impact;

Takes full account of disposal of product;

Ensure appropriate packaging;

Ensuring that the product functions efficiently through its life;

Reduces costs/time/materials for repairs;

Promotes reputation for reliability amongst consumers to enhance market share and profits;

[9 max]
